



EarthCraft House Technical Guidelines

Version 2.1

Table of Contents

Introduction	3
Certification Process	4
Site Planning (SP)	12
Resource Efficiency (RE)	20
Durability and Moisture Management (DU)	40
High Performance Building Envelope (BE)	56
Energy Efficient HVAC System (ES)	73
Indoor Air Quality (IAQ)	96
Plumbing and Irrigation (PI)	115
Lighting and Appliances (LA)	128
Education and Operations (EO)	135

Introduction

The EarthCraft House Technical Guidelines apply to all new construction and gut rehab projects pursuing the EarthCraft House certification, including single-family homes, duplexes, and townhomes. When verifying items for an EarthCraft project, EarthCraft Builders and EarthCraft Technical Advisors shall reference these Guidelines to ensure all requirements have been met.

If local building codes conflict with or are more stringent than the EarthCraft Technical Guidelines, the local code shall be followed. The Builder must notify the Technical Advisor of any changes required for the home to meet local codes.

Materials and methods described are representative of typical strategies that meet the intent of the criteria, but do not represent all strategies that may be used. The project team may request permission from EarthCraft to meet the intent of the credit using a different approach. Approval from EarthCraft must be obtained prior to implementation via the certification process.



The EarthCraft House Program



The EarthCraft House program prioritizes resource efficiency and smart construction practices. It is organized into with primary categories, each of which details specific criteria. The primary categories are:

SITE PLANNING	SP
RESOURCE EFFICIENCY	RE
DURABILITY & MOISTURE MANAGEMENT	DU
HIGH-PERFORMANCE BUILDING ENVELOPE	BE
ENERGY-EFFICIENT HVAC SYSTEMS	ES
INDOOR AIR QUALITY	IAQ
PLUMBING & IRRIGATION	PI
EFFICIENT LIGHTING & APPLIANCES	LA
EDUCATION AND OPERATIONS	EO

Projects seeking to further distinguish themselves for building performance, environmental awareness and/or occupant health and safety, may seek additional certification packages. These packages, or certification badges, fall into six (6) categories: Comfort (CMFT), Environment (ENV), Health (HLTH), Performance (PERF), Electrification (EL), and Resiliency (RES).

Badges are optional add-ons for any EarthCraft certified project. Each has its own requirements that projects must meet to obtain the badge. Since these badges serve to enhance different areas of the EarthCraft House program, their specific requirements may be distributed within multiple sections of the EarthCraft House worksheet. The table below highlights the areas each badge enhances:

	<p>The Comfort badge includes advanced heating and cooling systems, including high efficiency equipment, advanced distribution design and commissioning of systems. All items covered by the Comfort badge are located within the Energy Efficient Systems section of the EarthCraft House worksheet.</p>
	<p>The Health badge includes high-performance outdoor air ventilation systems and increased attention to finish materials. All the items covered by the Health badge are located within the Indoor Air Quality section of the EarthCraft House worksheet.</p>
	<p>The Environment badge includes site design and material selection items that support environmentally preferred construction practices. This badge covers the following areas of the EarthCraft House worksheet: Site Planning, Resource Efficiency, Plumbing & Irrigation.</p>
	<p>The Performance badge supports building construction practices and materials supporting a residential structure exceeding the IECC 2018 energy code for energy and water efficiency. This badge requires that projects complete an energy model to aid the design team as they plan a high-performance home. The Performance badge covers the following areas of the EarthCraft House worksheet: High Performance Building Envelope, Plumbing & Irrigation.</p>

	<p>The Electrification badge recognizes the importance of transitioning homes away from using fossil fuel energy sources and preparing them for renewable and on-site electricity generation. Using this badge requires an all-electric home, plus infrastructure or electric vehicles and a building design and construction process that prepares a home for rooftop solar.</p>
	<p>The Resiliency badge encompasses full self-reliance of a building. It combines efficient design and construction, appliances, and onsite electricity generation. Achieving the Resiliency badge includes the Electrification Badge.</p>

Certification Process

The EarthCraft House certification process is organized into six (6) steps:

1. Project Eligibility
2. Registration
3. Design Review
4. Mid-Construction Inspections
5. Final Inspection
6. Certification Review

Each step is explained below, with specific requirements identified for both EarthCraft Builders and EarthCraft Technical Advisors. Additional information about the EarthCraft certification process may be found in the EarthCraft Program Manual.

1. Project Eligibility

Projects that meet the below criteria are eligible for EarthCraft House certification:

- A. Single-Family detached
 - New construction, built upon a new foundation
 - Gut rehab, built upon an existing foundation
 - Ancillary structures that are intended to be habitable and share the same address as the primary house, such as a guest house or a suite above a garage, will be subject to the same criteria as the primary house
- B. Townhome, row home or duplex
 - Each dwelling unit must have its own unique postal address
 - No dwelling units are intended for rental purposes
 - Each dwelling unit will be registered as an individual project

Builder Responsibilities

Determine project eligibility

- Contact EarthCraft if you are uncertain which EarthCraft program your project qualifies for.

2. Registration

Projects that meet the above criteria are eligible for EarthCraft House certification. To initiate a new EarthCraft House project, a project registration form must be completed. A project may be registered by any individual involved with the project. The registration fee must be paid in full before certification will be awarded.

A project must be registered with EarthCraft prior to the completion of the mid-construction review

The EarthCraft House registration process may be completed online at:

- <https://earthcraft.org/programs/earthcraft-house/>

Builder Responsibilities

Hire an EarthCraft Technical Advisor (TA)

- The TA will track the project throughout the certification process and provide all EarthCraft verification, diagnostic testing, and applicable energy modeling services as they apply to the certification path selected by the builder.

If assigning registration responsibility to the Technical Advisor or another representative from the builder company, provide registrant with all the information needed to complete the registration form:

- Building type
- Conditioned square footage
- Number of stories
- Number of bedrooms
- Project address
- Billing contact
- Permit date

Technical Advisor Responsibilities

- Ensure the project has been registered with EarthCraft
- Review the EarthCraft project record that has been created in the EarthCraft Salesforce Community to ensure that the address and basic house data match the project

3. Design Review

The Design Review is an opportunity to identify project goals and ensure measures are in place to meet all the necessary criteria set by EarthCraft. If applicable, the preliminary energy model will be used to estimate performance and determine if any improvements are needed to achieve the Performance badge.

Builder Responsibilities

Send the following documents to the Technical Advisor for review:

- Completed construction specification sheet demonstrating how the project will meet EarthCraft requirements
- Project EarthCraft worksheet that lists which requirements will be applicable and which optional badges will be pursued, if any
- Manual J load calculations and Manual S equipment selection
- Drawings and specifications
- The builder shall note any areas of the project's EarthCraft worksheet they have questions on so that potential issues may be resolved during the design phase of the project

Technical Advisor Responsibilities

- Review all materials provided by the Builder
- Determine the project's ability to achieve certification
 - If necessary, develop options to meet program criteria
- Address all questions and concerns presented by the Builder
 - Contact EarthCraft if further clarification is needed
- Identify effective cost trade-offs for improving building performance
- Identify areas of potential confusion or failure
- If applicable, complete preliminary energy model

4. Mid-Construction Review

During the mid-construction review, the TA will begin to gather verification documentation and conduct the mid-construction inspection(s).

Builder Responsibilities

Schedule the initial mid-construction inspection(s) with your TA

- At least one (1) inspection must occur after air sealing and, at a minimum, exterior wall insulation installation has been installed, but prior to the hanging of drywall
- Ensure the project is ready for inspection:
 - Framing is complete; rough-in HVAC, plumbing, and electrical has been completed; pre-drywall air sealing is complete; and insulation installation must be complete and ready for visual inspection
 - The TA must be able to visually verify that framing, air sealing, insulation, and rough-in HVAC requirements have been met

Note: The minimum insulation installation that should be installed during the mid-construction review is for exterior wall insulation. If necessary, the TA may visually inspect attic and floor insulation during a final inspection. Builders shall discuss when all areas of insulation will be inspected with their TA during the design review, or prior to completing all inspections during the mid-construction review.

Technical Advisor Responsibilities

Follow up with Builder to ensure the inspection is scheduled during the appropriate time of construction

Perform the inspection

- Verify applicable EarthCraft House worksheet items
- Confirm the Manual J reflects the home as it will be constructed
- If applicable, confirm the energy model represents the home as it will be constructed

Inform the Builder if the project passed inspection

- If necessary, outline items that need correction or further attention

5. Final Review

As construction activities near completion, the Technical Advisor will verify all remaining worksheet items and conduct final diagnostic testing.

Builder Responsibilities

Schedule the final inspection with your TA

- Inspection shall occur after all interior finishing work has been completed, but prior to occupancy

Ensure the project is ready for inspection

- All unverified EarthCraft worksheet items must be completed and accessible

Technical Advisor Responsibilities

Follow up with Builder to ensure the inspection is scheduled during the appropriate time of construction

Perform the inspection

- Conduct diagnostic testing
- Verify applicable EarthCraft House worksheet items
- If applicable, confirm the energy model represents the home as constructed

Inform the Builder if the project passed inspection

- If necessary, outline items that need correction or further attention

6. Certification

At certification the TA will provide EarthCraft with all documentation necessary for review. After EarthCraft has reviewed and accepted all documentation, the certificate will be awarded.

Technical Advisor Responsibilities

Complete the inspection report

- This must be completed no later than forty-five (45) days after the first final inspection
- Create a new inspection record in Salesforce and populate the relevant input fields

Assemble the certification submittal package

- Final, completed EarthCraft House worksheet
- EarthCraft House Worksheet cover, signed by builder and TA
- Projects showing compliance through an energy model* must submit:
 - Home Energy Rating Certificate (HERS Certificate) or ERI certificate
 - IECC Fuel Summary Report

*Energy models must be confirmed by the provider prior to submitting to EarthCraft.

*Reports without print permission or not listed as confirmed will not be accepted

Submit all submittal documents to EarthCraft

- This must be completed no later than forty-five (45) days after the first final inspection
- Create a new certification submittal record in Salesforce and attach all the required documentation

Site Planning (SP)

The location of a home and the plan for the area around that home can have a significant impact on both the resident's quality of life and on the environment. Selecting an appropriate site for a home is essential to creating more walkable, livable communities with efficient transportation. One can also improve the air quality in a neighborhood, help manage storm water, lower energy bills and increase property values simply by protecting and restoring trees on a site. Planning for construction on a site can prevent soil loss and water pollution by reducing erosion and properly controlling for storm water.

The Site Planning category of the EarthCraft program focuses on actions that a builder can take to minimize the direct impact of a building site on the environment. These actions range from protecting excavated topsoil from erosion to reducing lot size. Projects may also implement additional site planning measures to promote accessibility to public amenities such as mass transit and parks or using degraded sites such as brownfields.

SP 1: Do not install invasive plant species

Purpose

Invasive species are region-specific, non-native plants that tend to spread aggressively and decrease native biodiversity.

Criteria

Do not include plants on the irrigation plan that have been identified by the state's agriculture or cooperative extension as a non-native, invasive Category 1-2 species, except for Bermuda grass (*cynodon dactylon*).

Additional Resources

For an up-to-date list of invasive species and associated categories please refer to the state guidelines for the project site

- Alabama:
 - Alabama Forestry Commission: https://forestry.alabama.gov/Pages/Fire/Invasive_Species.aspx
- Florida:
 - Florida Invasive Plant Species Mobile Field Guide: <http://www.plantatlas.usf.edu/flip/>
- Georgia:
 - Georgia Exotic Pest Plant Council: <https://www.gaepcc.org/list/>
- Louisiana:
 - Tulane University & Xavier University Center for Bioenvironmental Research: <http://is.cbr.tulane.edu/index.html>
- North Carolina:
 - North Carolina Native Plant Society: https://www.ncwildflower.org/plant_galleries/invasives_list
- South Carolina:
 - Invasive Plant Species of South Carolina: <https://www.se-eppc.org/southcarolina/scinvasives.pdf>
- Tennessee:
 - Tennessee Invasive Plant Council: <https://www.tnipc.org/invasive-plants/>
- Virginia:
 - Virginia Department of Conservation and Recreation: <https://www.dcr.virginia.gov/natural-heritage/invspdflist>

Confirmation

The EarthCraft Technical Advisor will confirm compliance based on irrigation list provided by the builder prior to submitting project for certification.

Example

Miscanthus Sinensis is a Category 2 invasive species in Georgia and is not allowed to be planted on an EarthCraft House project.

SHRUBS				
KEY	BOTANICAL NAME / COMMON NAME	SIZE	SPACING	QTY.
⊙	BUXUS MICROPHYLLA VAR. KOREANA 'WINTERGREEN' / KOREAN BOXWOOD	3 GAL.	30" O.C.	170
⊙	BUXUS MICROPHYLLA VAR. KOREANA 'WINTERGREEN' / KOREAN BOXWOOD	5 GAL.	AS INDICATED	3
⊙	GARDENIA JASMINOIDES 'AUGUST BEAUTY' / AUGUST BEAUTY GARDENIA	3 GAL.	5' O.C.	72
⊙	GARDENIA JASMINOIDES 'RADICANS' / DWARF GARDENIAS	3 GAL.	30" O.C.	128
⊙	HYDRANGEA MACROPHYLLA 'BAILMER P.P. #15,298' / ENDLESS SUMMER HYDRANGEA	3 GAL.	30" O.C.	38
⊙	HYDRANGEA QUERCIFOLIA 'PEEWEE' / OAKLEAF HYDRANGEA	3 GAL.	3' O.C.	81
⊙	ILLICIUM PARVIFLORUM / ANISE	3 GAL.	4' O.C.	179
⊙	ITEA VIRGINICA 'HENRY'S GARNET' / VIRGINIA SWEETSPIRE	3 GAL.	3' O.C.	184
⊙	MISCANTHUS SINENSIS 'MORNING LIGHT' / MAIDEN GRASS	3 GAL.	3' O.C.	54
⊙	PRUNUS LAUROCERASUS 'OTTO LUYKEN' / OTTO LUYKEN LAUREL	3 GAL.	3' O.C.	16
⊙	ROSA 'RADAZZ' / KNOCKOUT ROSE	3 GAL.	3' O.C.	66
⊙	ROSMARINUS OFFICINALIS / ROSEMARY	3 GAL.	18" O.C.	5

SP 2: Install and Maintain a Tree Protection Plan

Purpose

Any activity that changes the soil conditions, or disturbs branches, trunks, or root systems is extremely detrimental to a tree's health. A tree protection plan outlines the steps that will be taken to preserve trees and critical root zones.

Criteria

A professional landscape architect or certified arborist shall develop a tree preservation site plan prior to clearing, grading or commencement of construction activities, which identifies existing trees with diameter at breast height (DBH) dimensions exceeding 3" and designates ≥20% of those trees to be protected during all construction activities.

Tree root zones (area extending in all directions from the trunk) must be protected with a physical barrier to minimize all disturbances, including those from parked vehicles and construction material storage. Set fences firmly; if wood fences are used, they must be a minimum of 2x2 lumber. Do not place any soil from clearing, grading or construction activity on top of any root zone for trees designated on a site plan to be preserved. Trees that are marked to be preserved on a site plan and for which utilities must pass through the root zones must not have surface dug trenches. Dig tunnels through the root zone in order to minimize root damage.

The builder must:

- Review tree preservation plan with subcontractors
- Post plan on job site.

Confirmation

The builder must present documentation demonstrating compliance of criteria to the EarthCraft Technical Advisor during the design review process.

The EarthCraft Technical Advisor will review documentation provided by the builder and will visually confirm compliance during the mid-construction and final inspections.

Examples:



Figure 1: Tunnel to minimize root damage (left) as opposed to surface-dug trenches root zone (right)



Protect the critical root zone from potential materials staging/storage (above)

ENV 1: Pre-Construction Site Assessment and Remove 100% of invasive plants from 100% of site

Purpose

Invasive plant species spread quickly and displace native plants, which may cause economic or environmental harm, or harm to human health.

Criteria

All existing plants that are listed in Category 1 or 2 (with the exception of Bermuda grass) by state guidelines must be removed and properly disposed of.

Additional Resources

- Please refer to SP 1: Do not install invasive plant species

Confirmation

- The builder must present documentation demonstrating compliance of criteria to the TA prior to submitting project for certification.
- The TA will review documentation provided by the builder for compliance.

ENV 2: Permanent stormwater control \geq 50% of onsite impervious surface areas

Purpose

Impervious surface runoff should be properly located to drain away from building foundation to protect the home from moisture damage.

Criteria

Control disturbed site area by integrating Low Impact Development Best Management Practices (LID BMP) into the project. All BMPs shall be properly located to drain away from building foundation to protect home from moisture damage.

Projects must redirect at least 50% of onsite impervious surface areas from storm drains by implementing some or all the LID BMPs from the list below:

1. Direct impervious surface runoff to appropriately sized rain gardens, swales, drywells, or bio-retention areas. Receiving area soils shall be amended to increase infiltration to the level required for maintaining storm water. Keep area protected from heavy machinery and parking during construction or mitigate soil compaction post construction.
2. Design and install rooftop gardens and/or green roofs.
3. Direct roof or site runoff into rain barrels and/or cisterns. Size barrels and cisterns appropriately and enable use of water for building reuse or landscape irrigation.

Additional Resources

- Low Impact Development (LID) Urban Design Tools Website:
<https://www.lid-stormwater.net/>
- Georgia Stormwater Management Manuals:
<https://atlantaregional.org/natural-resources/water/georgia-stormwater-management-manual/>
- National Resource Defense Council Water Smart Cities:
<https://www.nrdc.org/issues/water-smart-cities>

Confirmation

The EarthCraft Technical Advisor will visually confirm compliance of criteria at final inspection.

ENV 3: Reduce irrigated area and install drought tolerant landscaping (both, details below):

- **Turf \leq 40% of landscape area**
- **Drought-tolerant and/or native landscaping turf and plants**

Purpose

Minimizing or eliminating lawns and integrating drought tolerant landscaping saves water, energy, and reduces the volume of fertilizers that pollute waterways.

Criteria

Design irrigated area with \leq 40% turf and use only drought-tolerant and/or native species for all irrigation.

Additional Resources

A list of drought-tolerant/native landscaping turf and plants may be obtained through a local cooperative extension office

Confirmation

The EarthCraft Technical Advisor will visually confirm compliance of criteria at final inspection.

Resource Efficiency (RE)

Forests provide habitats to diverse animal species, offer watershed protection, prevent soil erosion and help maintain the water cycle. EarthCraft House encourages the protection of forests through resource efficient design. By taking the time to design a home to use less wood and by practicing simple measures to ensure that wood on site is used properly, a new home can reduce its impact the environment as well as cost less money to build.

EarthCraft projects can meet the requirements of the Resource Efficiency category through methods such as designing homes with 2' dimensions, employing advanced framing techniques and providing clear framing plans and cut lists to contractors. These methods not only reduce the amount of lumber used on site, but also save money through reduced material costs, reduced tipping fees and increased customer satisfaction including improving the home's energy efficiency.

Building materials come from a variety of sources, not all of which are environmentally friendly. The EarthCraft program strives to reduce the impact homes have on the environment, including the impacts that result from the extraction and manufacture of materials used in home construction. By choosing certain building materials, an EarthCraft Builder can reduce building costs, conserve natural resources, prevent unnecessary waste, and reduce pollution associated with manufacturing and transporting of materials.

RE 1: Minimum stud spacing: 16" centers for 2x4 walls; 24" centers for 2x6 walls

Purpose

Using the minimum amount of wall studs (and eliminating studs that lack a structural purpose) reduces thermal bridging and allows more space for insulation in addition to conserving lumber.

Criteria

Minimum stud spacing at 16" centers for 2x4 walls and 24" centers for 2x6 walls unless construction documents specify that alternate spacing is structurally required. No more than 5% of studs may lack a structural purpose.

The builder must present construction documents demonstrating structural requirements for excess framing greater than 5%.

Confirmation

The EarthCraft Technical Advisor will visually confirm compliance of criteria at mid-construction inspection.

Example

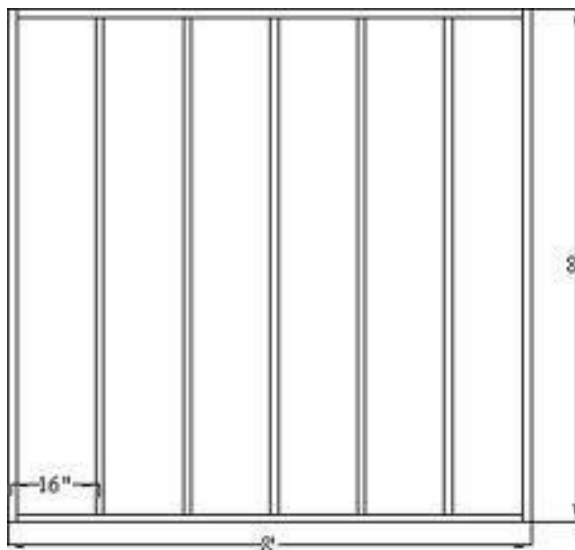

Correct

Construct load-bearing walls with 16 inches on center (OC) stud spacing for 2x4 framing.

RE 2: Size headers for loads (non-structural headers in non-load bearing walls)

Purpose

Minimize waste by designing and installing appropriately sized headers in all walls. Headers should be sized to accommodate the correct load.

Criteria

Design and install appropriately sized headers in all walls. Eliminate installation of load bearing headers in all non-load bearing walls and do not size all headers in load bearing walls to accommodate the greatest load case.

Clarification

Consult local building codes in areas susceptible to high wind or seismic regions.

Confirmation

The EarthCraft Technical Advisor will visually confirm compliance of criteria at mid-construction inspection and collect supporting documentation, if necessary.

RE 3: Insulated corners at all exterior locations

Purpose

Insulated corners reduce energy waste through thermal bridging by allowing more space for insulation.

Criteria

Insulate the intersecting corner of two exterior walls to $\geq R-6$. EarthCraft will accept two-stud ("California corner") and two-stud corners with an offset stud to meet the intent of this criteria.

Clarifications

- Load-bearing corners in multi-story buildings or where porches/porch roofs are designed may request a waiver for this requirement
- The corner must be fully insulated to achieve the intent of this criteria; therefore, corners with more than three studs are not permitted.

Confirmation

The EarthCraft Technical Advisor will visually confirm compliance of criteria at mid-construction inspection.

Examples

Correct

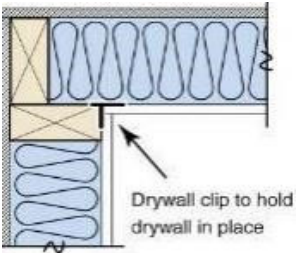

Incorrect



Include details in framing plan that specify insulated corners, such as "California Corner" framing.

Corners that are stacked with unnecessary framing that removes insulation from exterior corners are not allowed.

RE 4: Ladder T-walls at all exterior locations

Purpose

This method reduces the amount of framing members at the exterior wall and allows space for insulation, therefore reducing framing costs and thermal bridging.

Criteria

At interior-exterior wall intersections, the exterior wall should feature a ladder T-wall. Insulation should be installed at the exterior ladder T-wall to fill the cavity to full R-value.

Clarifications

- Consult local building codes in areas susceptible to high wind or seismic regions.
- If installing a ladder T-wall, begin first ladder 2' above the subfloor to aid in the installation of drywall.

Confirmation

The EarthCraft Technical Advisor will visually confirm compliance of criteria during the mid-construction inspection.

Examples

Correct



Install ladder t-walls where interior and exterior walls intersect to allow for maximum insulation coverage

Incorrect



Improper framing of intersection at exterior and interior walls. This method does not allow for insulation behind the framing.

RE 5: Insulated headers for all exterior doors and windows

Purpose

Remove unnecessary wood in headers and replace it with an insulating material

Criteria

Install a minimum R-5 insulation in headers at all exterior doors and windows.

Confirmation

The EarthCraft Technical Advisor will visually confirm compliance of criteria during the mid-construction inspection.

Example

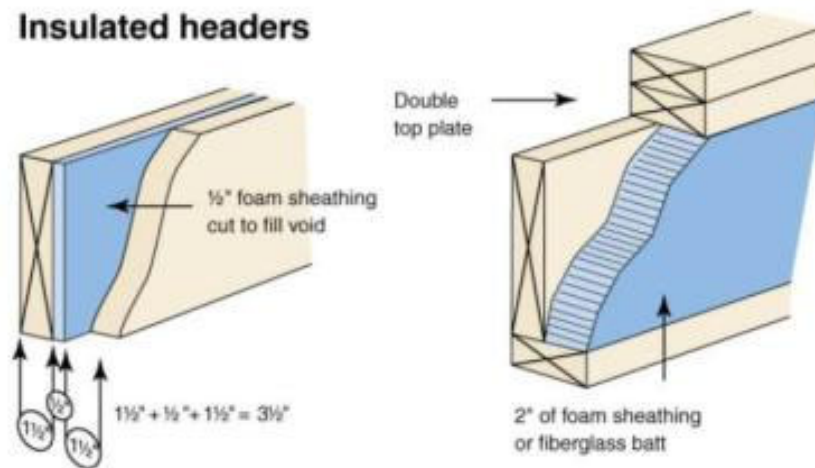

Insulate the framing over exterior doors and windows. Two options are (left) a 1/2" foam board between two 1 1/2" framing members or (right) 2" foam board installed at the interior side of 1 1/2" framing.

RE 6: Energy heel truss system or raised top plates for all vented, unconditioned attics

Purpose

Raised heel, energy trusses extend further past the wall and are deeper at the wall, thus allowing room for full insulation coverage over the top plate of the exterior walls.

Criteria

Install energy heel trusses or raised top plates to ensure full depth of attic insulation above exterior wall top plates. Depth of insulation above top plate may be traded to R-21 when allowed by local building code.

Confirmation

The EarthCraft Technical Advisor will visually confirm compliance of criteria at mid-construction inspection.

Example

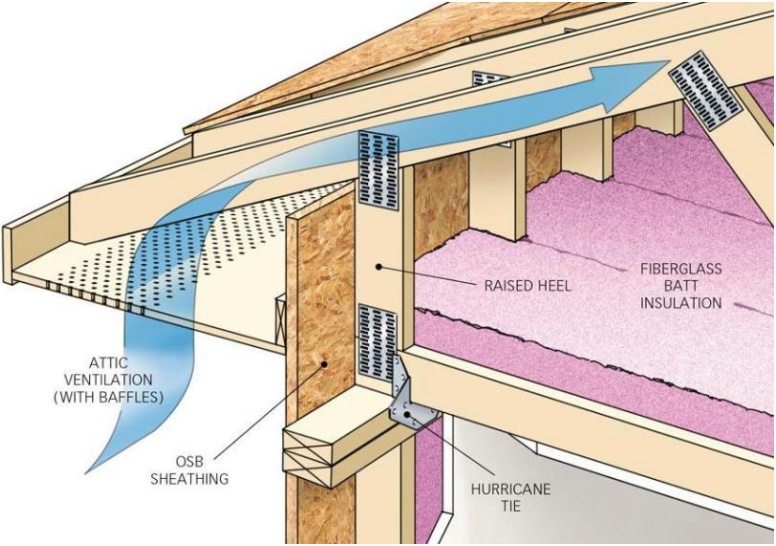

Energy heel trusses allow for the full depth of insulation over the entirety of the conditioned space.

RE 7: If HVAC ductwork is in unconditioned attic, attic side radiant barrier

Purpose

Control attic temperatures during the summer months by providing a radiant barrier along the roofline to minimize heat gain in the attic space.

Criteria

Install attic roof decking material with an integrated radiant barrier or install a radiant barrier material along the roofline that the truss system. The radiant barrier side of the material selected should be left exposed to the attic air space and only come into direct contact with the roofing system where it attaches to the roof rafters. Do not install insulation in contact with the radiant barrier.

Confirmation

The EarthCraft Technical Advisor will visually confirm compliance of criteria at mid-construction inspection.

Example



Radiant material can be retroactively installed to the underside of the roof truss.



Radiant barrier material integrated with the roof decking.

RE 8: Engineered trim: interior and exterior ≥75%

Purpose

Engineered products offer both resource and durability benefits when compared to traditional wood products by resisting rot when exposed to elements (exterior) and are a more effective use of resources.

Criteria

Install a minimum of 75% of total exterior and interior trim from non-solid sawn wood (e.g., finger-jointed wood, medium or high-density fiber board (MDF or HDF), etc.) or non-wood material, such as PVC. All non-solid sawn wood products must have no added urea-formaldehyde.

Clarification

Stain grade trim does not count towards percentage of trim material covered by these criteria.

Confirmation

- Builder shall provide documentation of materials selected to TA prior to submitting project for certification.
- The EarthCraft Technical Advisor will visually confirm compliance of criteria at mid-construction and final inspections

ENV 4: Advanced framing package (choose one, details below):

- Deliver panelized construction or SIPS to the site pre-framed
- Site framing plan with precut framing package
- Optimum value engineering framing for walls, floors, and roof

Purpose

Advanced framing results in savings on materials costs to builders, reduces the amount of labor needed for installation, reduces environmental impact due to more strategic cutting of material and reduces thermal bridging.

Criteria

Review complete framing plan and framing package with framing contractor to reduce unnecessary framing. The framing plan must illustrate the location and size of every stud, cripple, plate, header and other framing members in the roof, walls and floors. The precut framing package must correspond directly with framing plan.

1. Floors

Construct a minimum of 90% of the floor area using a panelized floor system (e.g., structurally insulated panels) delivered to the jobsite pre-framed and precut. In all cases, install panelized floor according to manufacturer specifications.

2. Exterior walls

Construct a minimum of 90% of all walls separating conditioned space from unconditioned space using panelized wall systems (e.g., structurally insulated panels) delivered to the jobsite pre-framed and precut. In all cases, install panelized walls according to manufacturer specifications.

3. Roof

Construct a minimum of 90% of the roof area using a panelized roof system (e.g., structurally insulated panels) delivered to the jobsite pre-framed and precut. In all cases, install panelized roof according to manufacturer specifications.

Clarifications

- Thermal mass and infiltration effects may not be included in R-value.
- Floor area must be calculated using RESNET standards for conditioned floor area.

Confirmation

- The builder shall provide all necessary framing documentation to the TA prior to the mid-construction inspection
- The EarthCraft Technical Advisor will visually confirm compliance during the mid-construction inspection

ENV 5: Recycled content materials (choose two, details below):

- **Replace > 25% of cement in slab and/or foundation wall concrete with fly ash or slag**
- **Install >50% recycled content insulation**
- **Install >50% recycled content carpet on >50% of all carpeted floor**

Purpose

Recycled content materials lower the overall embodied energy of a project. For example, some recycled materials, such as concrete, require less energy to make them than their "virgin" counterparts. Fly ash and slag are also byproducts of coal production/energy use, so by removing them from the waste stream and finding a way to repurpose these byproducts, the environmental impact of the concrete is reduced.

Selecting insulation that contains a significant percentage of recycled content allows for material reuse and recovery while diverting materials that would otherwise be destined for landfills.

Selecting flooring with recycled content achieves this goal in a similar manner.

Criteria

- Replace $\geq 25\%$ of the cement with fly ash or slag in all concrete used for footings, foundation and basement walls and slabs.
- Install 100% of insulation with $\geq 50\%$ recycled material (pre- or post-consumer) content by weight or volume in all walls, floors, and ceilings.
- Install carpet with $\geq 50\%$ recycled content (pre- or post-consumer) on 50% of carpet floor area.

Clarifications

Floor area must be calculated using RESNET standards for conditioned floor area.

Confirmation

- The builder shall provide documentation demonstrating compliance of the criteria for each material selected by providing the Technical Advisor with cut sheets, Material Data Sheets (MDS), and or manufacturer specification sheets prior to the mid-construction inspection.
- The EarthCraft Technical Advisor will review all documents provided by the builder for compliance with criteria.

ENV 6: Responsible waste disposal (minimum of two, must divert ≥75% of all selected):

- **Wood**
- **Drywall (recycle or grind and spread onsite)**
- **Cardboard**
- **Plastics**
- **Styrofoam**

Purpose

Responsible waste management is an essential component to reducing job-site waste. By posting it on the job site, you better ensure that the plan will be followed throughout the entire construction process by all on-site staff and trade contractors.

Criteria

Post a construction waste management plan on site and educate each subcontractor on the aspects of the plan that pertains to their work and enforce these measures. The waste management plan must either provide for onsite separation of materials to be recycled or provide for separation of recyclable materials by clean-up or waste hauling firms. The builder must maintain documentation on diversion rate for each material.

Wood

- Avoid disposal of a minimum of 75% (by weight) of solid sawn wood by recycling through a state or county approved program or by on-site grinding and application of wood chips as mulch.
- Pressure treated wood is exempt from this requirement and may not be milled or applied as mulch.

Drywall

- Avoid disposal of a minimum of 75% (by weight) of drywall generated from construction activities through an approved recycling program, or by onsite grinding and application of drywall as a soil amendment.
- Only unpainted drywall is eligible for this requirement.

Cardboard

- Avoid disposal of a minimum of 75% (by weight) of cardboard generated from construction activities through an approved recycling program.
- Cardboard and mixed paper are both eligible for this requirement

Plastics

- Avoid disposal of a minimum of 75% (by weight) of plastics generated from construction activities through an approved recycling program.
- Plastics to be included are Plastics #1, #2, #4, #6 and #5

Styrofoam

- Avoid disposal of a minimum of 75% (by weight) of Styrofoam generated from construction activities through an approved recycling program.

Additional Resources

For the NAHB Research Center's "Builder's Field Guide to Residential Construction Waste Management" publication see [here](#).

Confirmation

- The builder must present documentation demonstrating compliance of criteria to the EarthCraft Technical Advisor prior to submitting project for certification
- The EarthCraft Technical Advisor will review documentation provided by the builder for compliance and will visually confirm compliance during the mid-construction inspection.

RES 1: Include all elements of the Electrification Badge

Purpose

The Resiliency Badge is intended to guide homebuilders, and designers towards producing residences that enable self-reliance and long-term accessibility for their occupants. Because of this, the Resiliency Badge requires a home that is disconnected from non-renewable fossil fuels such as natural gas or propane, equipped with onsite solar electricity generation, and provided with the infrastructure needed to assist residents with utilizing all-electric vehicle transportation.

Criteria

The full list of the Electrification Badge include:

- EL 1: All-electric home with the following:
 - Solar-ready electrical panel
 - One (1) electric vehicle charging station
 - Electric air source heat pump or ground source heat pump HVAC systems meeting ES 2 and ES 3
 - Electric water heater equipment meeting PI 1.
 - No utility gas line service for any secondary appliances (fireplaces, outdoor cooking, etc.)
- Solar ready building design and construction
 - Solar orientation optimization of roof
 - Rooftop constructed to bear weight of solar panels
- Energy modeling to confirm home is designed to be net-zero or net-positive post-occupancy with properly sized solar panels

Confirmation

- The builder must present documentation demonstrating compliance of criteria to the EarthCraft Technical Advisor prior to submitting project for certification
- The EarthCraft Technical Advisor will review documentation provided by the builder for compliance and will visually confirm compliance during the mid-construction and final inspections.

RES 2: Rooftop solar or site-specific solar panels

Purpose

Provide home with a permanent source of on-site solar electricity generation

Criteria

Design and install rooftop or on-site solar panels capable of meeting a minimum of 40% of the peak daily electrical load of the house using approved energy model simulations.

Clarifications

- Whole-house energy modeling must be conducted to ensure that the building can achieve net-zero or net-positive grid electrical consumption post-occupancy.
- Solar panels installed on the home are not required to provide 100% of the home's electrical usage, however the structure and electrical panel design and installation shall be provided to enable future solar panel installation post-occupancy

Confirmation

- The builder must present documentation demonstrating compliance of criteria to the EarthCraft Technical Advisor prior to submitting project for certification
- The EarthCraft Technical Advisor will review documentation provided by the builder for compliance and will visually confirm compliance during the mid-construction and final inspections.

RES 3: Incorporate Universal Design in ground-floor of building

Purpose

Design and construct a home that is accessible to residents regardless of age, disability, or other factors.

Criteria

The complete list of specific requirements is:

- Hallways have a net clear width of 36"
 - Design all ground-level hallways with a width capable of navigating a wheelchair or walker safely through them
- Passage doors (interior and exterior) have a net clear opening of 32"
 - Design all ground-level interior and exterior doors with an opening capable of navigating a wheelchair or walker through them
 - Maintain a smooth clearance in the floor between rooms at each doorway
- At least one (1) bathroom designed with:
 - A 30" x 48" clear floor space outside the swing of the door as it closes
 - A 30" x 48" clear floor space for the sink
 - A 30" x 48" clear floor space for the toilet
 - A 30" x 48" clear floor space for the tub/shower
 - Toilet centered a minimum of 18" from any corner wall, base cabinet, or tub/shower
 - The basin for cabinet-style sink centered in the required clear floor space for sinks or be located 24" from any adjacent wall or tub that prevents full parallel approach
 - Wall reinforcement behind the toilet, tub, and/or shower shall be equipped with properly anchored and supported grab bars or install 2" x 10" wood blocking, plywood, or other approved material to support future grab bars installation in the toilet and tub/shower areas. The wall reinforcement shall be located 33" to 36" above finished floor area (FFA)
- At least one (1) building entry door with:
 - An exterior level platform with a minimum of 5' x 5' clear floor space. This platform must be within ½" of the interior finished floor at the point of entrance and a maximum threshold rise of 1 ¼" when approaching from the outside (structural and decorative supports may overlap perimeter of the clear floor space).

Additional Resources:

- Universal Design Standards:
 - <https://www.wvhdf.com/wp-content/uploads/2017/12/UDS020808.pdf>

Confirmation:

- The builder must present documentation demonstrating compliance of criteria to the EarthCraft Technical Advisor during the design review stage.
- The EarthCraft Technical Advisor will review documentation provided by the builder for compliance and will visually confirm compliance during the design review and mid-construction stages.

Durability and Moisture Management (DU)

An important aspect of building a sustainable home is ensuring durability throughout its life cycle. EarthCraft House recognizes that proper design and installation are integral to building a durable home with minimal moisture management issues. Reducing the life cycle costs due to maintenance, repair and replacement decreases the impact that home construction, and reconstruction, have on the environment. The durability and moisture management section includes items that improve long-term durability, occupant health and comfort.

DU 1: Do not install wet or water-damaged building materials

Purpose

Moisture can cause long term damage to building materials. Wood products swell when they take on moisture and this change in dimension can create problems during installation. Additionally, water may weaken adhesive bonds.

High moisture content can also promote the growth of mold. Installing moldy materials in a building or failing to properly treat building components that become wet, can expose buildings to potential structural weakness and/or poor indoor air quality when the structure is occupied.

Criteria

Do not install building materials that have visible signs of water damage or mold.

Clarifications

Do not enclose walls if the framing members or the insulation has high moisture content (framing members shall be dried to at least 18% moisture content). Follow the manufacturer's drying recommendations for wet-applied insulation and test framing members for moisture prior to enclosing wall cavities.

Confirmation

The EarthCraft Technical Advisor will visually confirm compliance of criteria at mid-construction inspection.

If high moisture or mold is found during the mid-construction inspection, the builder must present documentation demonstrating compliance of criteria to the EarthCraft Technical Advisor. Documentation may include moisture content test results, mold remediation invoices/reports or the equivalent.

Example



Do not install wet building materials or leave building materials exposed to standing water. If materials are exposed to moisture after installation, drain/dry area and treat for mold as necessary

DU 2: Crawlspace, if designed (choose one):

- **Vented Crawlspace**
- **Unvented Crawlspace**

Purpose

Traditional vented crawlspaces are known sources of elevated moisture that can result in damage to framing members and introduce pollutants to living spaces.

Properly unvented crawlspaces keep out unwanted moisture better than conventional, wall vented crawlspaces in temperate-humid climates. Homes with closed crawlspaces (aka "sealed," "unvented," or "conditioned") also can save significantly on energy when compared to homes with wall-vented crawlspaces because they reduce energy loss through the floor of a building.

Properly installed crawlspace ground vapor barriers will prevent the accumulation of ground moisture and soil gases in the crawl space.

Criteria

Option A: Vented crawlspace meeting 2018 IRC and EarthCraft insulation requirements:

- 100% coverage of sealed ≥ 12 mil vapor barrier over exposed earth. Vapor barrier shall extend ≥ 6 " up the stem wall and shall be attached and sealed to the stem wall.
- Spray foam insulation covering 100% of framed floor

Option B: Unvented crawlspace meeting 2018 IRC and EarthCraft insulation requirements:

- $\geq R-5$ continuous insulation installed in contact with foundation wall.
- Exposed earth is covered with a continuous ≥ 12 mil vapor barrier. Joints of the vapor barrier shall overlap by 6" and shall be sealed. The edges of the vapor retarder shall extend ≥ 6 " up the stem wall and shall be attached and sealed to the stem wall or insulation; AND
- One of the following is provided for under the under-floor space:
 - Continuously operated mechanical exhaust ventilation at a rate equal to 1 cubic foot per minute for each 50 square feet of crawlspace floor area, including an air pathway to the common area (such as a duct or transfer grill) and perimeter walls insulated in accordance to IECC 2015.
 - Conditioned air supply sized to deliver at a rate equal to 1 cubic foot per minute for each 50 square feet of under-floor area, including a return air pathway to the common area (such as a duct or transfer grill) and perimeter walls insulated in accordance with IECC 2015
 - ENERGY STAR certified dehumidifier capable of maintaining $\leq 60\%$ relative humidity in crawlspace. Dehumidifier must be equipped with a pump and drain line that terminates at the building exterior.

Clarifications

- Not required if project is located in 100-year flood plain.
- Drainage, pests and combustion safety issues are important considerations when sealing a crawlspace.

Confirmation

- The EarthCraft Technical Advisor will review plans with builder, and if necessary, the HVAC contractor, during design review to confirm foundation design.
- TA will verify compliance of foundation space during the mid-construction and final inspections.

Examples

Closed Crawlspace



Follow IRC 2012 for strategies on designing and constructing a closed crawlspace. Closed crawlspaces should have a properly installed vapor barrier, insulation on the crawlspace wall, and a method for providing dehumidification to the space.

Vented Crawlspace



Floor insulation of SPF that covers 100% of framed floor, with a properly installed vapor barrier covering 100% of exposed dirt floor is permitted.

DU 3 Slabs, if designed (both, details below):

- **100% coverage of ≥ 6 mil vapor barrier beneath all slab**
- **≥ 4 " Deep gravel bed beneath all slabs (exception: Climate Zone 2)**

Purpose

A vapor barrier serves to prevent water vapor and soil gases from coming into contact with the concrete slab. Gravel beds allow for groundwater drainage and can act as a capillary break and prevent groundwater from coming in contact with the slab.

Criteria

Install a vapor barrier ≥ 6 mil beneath all slabs to prevent soil moisture and gases from entering the home. Provide 100% coverage. Overlap and seal all vapor barrier joints a minimum of 6".

Install a ≥ 4 " deep gravel bed (consisting of ≥ 0.5 " clean aggregate beneath on-grade or raised concrete floor slabs (not required if project is located in Climate Zone 2).

Clarifications

Gravel bed must be installed beneath vapor barrier. If gravel is not available, install a ≥ 4 " of uniform layer of sand with geotextile drainage matting.

Confirmation

- The builder will illustrate compliance of criteria through photo documentation submitted to the EarthCraft Technical Advisor prior to mid-construction inspection.
- The EarthCraft Technical Advisor will review photo documentation provided by the builder for compliance of criteria.

Examples



Install a continuous vapor barrier of ≥ 6 mil plastic prior to pouring slab.

DU 4: Bottom of foundation drain no higher than top of subgrade footing

Purpose

Foundation drains capture and direct water away from the foundation walls and footings and help to ensure low levels of soil saturation. Increased hydrostatic pressure on the footing/foundation can cause excess stress on the joints of the foundation.

Criteria

Install a protected foundation drain tile outside of the footing or, at the highest point, directly on top of the footing. Use appropriate drain elbows for bends to prevent drainage constriction around corners. Surround each pipe with $\geq 6''$ of 1/2"- 3/4" gravel and wrap gravel layer fully with fabric cloth. Discharge all drain lines away and downhill from the foundation to outside grade/daylight, drywell or to a sump pump.

Clarifications

- Place the drainage pipe with the perforations facing down.
- A filter fabric sock for the drainage pipe may be used instead of wrapping the pipe and gravel in filter fabric.

Confirmation

- The builder will illustrate compliance of criteria through photo documentation submitted to the EarthCraft Technical Advisor prior to the mid-construction project review.
- The EarthCraft Technical Advisor will review photo documentation provided by the builder or visually confirm for compliance of criteria.

DU 5: Damp proof below-grade walls

Purpose

Damp proofing prevents moisture and water passing through walls to interior spaces, preventing timber decay and structural damage.

Criteria

Apply damp proofing for all below-grade walls. Damp proofing materials are typically roller- or spray-applied asphalt coatings and/or bituminous felt.

Clarifications

- Wood-framed below-grade walls are not permitted along the exterior of the home.
- Do not install Class 1 vapor retarders on the interior side of air permeable insulation in exterior below-grade walls, except for tile at showers and tub walls.

Confirmation

- The builder will illustrate compliance of criteria through photo documentation submitted to the EarthCraft Technical Advisor prior to the mid-construction project review.
- The EarthCraft Technical Advisor will review photo documentation provided by the builder or visually confirm for compliance of criteria.

Example



Damp proofing of below grade wall with a bituminous felt material.

DU 6: Install drainage plane per manufacturer's specifications (both, details below):

- **Single lapped housewrap or taped, vapor permeable water-resistant barrier integrated with sheathing**
- **Double layer of either building paper or house wrap behind cementitious stucco, stone veneer, or synthetic stone veneer on framed walls**

Purpose

Most of all exterior wall claddings will allow water to pass through them. Therefore, a drainage plane is required to keep rainwater from entering the wall cavity and allows the water to drain down the wall. Drainage planes provide this rainwater control but must be installed and sealed as instructed by the manufacturer on the entire building assembly exposed to the exterior to be effective.

Criteria

See above language and reference manufacturer's instructions for installation.

Clarifications

- A drainage plane must be installed and sealed as instructed by the manufacturer on the entire building assembly exposed to the exterior.
- Brick veneer requires a single layer of housewrap or taped, vapor permeable water-resistant barrier integrated with sheathing.
- The International Residential Code requires that "exterior plaster" (stucco) be installed over "a water-resistive vapor-permeable barrier with a performance at least equivalent to two layers of Grade D paper." All unvented, exterior cladding in contact with the substrate must meet the criteria.
- A single layer of building paper coupled with a single layer of house wrap meets the intent of the criteria.
- For stucco cladding systems, include weep screed per manufacturer's specifications.

Confirmation

- The builder will illustrate compliance of criteria through photo documentation submitted to the EarthCraft Technical Advisor for the mid-construction review.
- The EarthCraft Technical Advisor will review photo documentation provided by the builder or visually confirm for compliance of criteria.

Examples

Correct



Correct

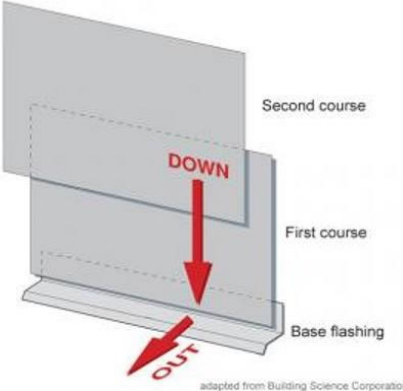

DU 7: Flashing complies with 2021 IRC and/or manufacturer specifications

All of the following must be met:

- All exterior penetrations flashed and sealed to the weather barrier prior to cladding
- Window and door pan flashing installed per manufacturer specifications
- Window and door side and head flashing installed per manufacturer specifications
- Step and kick-out flashing at all wall/roof intersections
- Step flashing to 4" on wall surface and integrated with wall and roof drainage plane

Purpose

Windows and doors are an interruption in the wall's house wrap and therefore a vulnerable spot for water leakage. Properly installed flashing that is integrated with the other elements of the wall can help prevent water damage by directing water away from, rather than into, the wall cavity.

Criteria

See above language and reference manufacturer's instructions for installation.

Clarifications

- For metal and rubber membrane roofs, install continuous flashing in place of step flashing.
- For porches, install L-shaped flashing to the top of the ledger board and integrate with drainage plane (vertical leg of the flashing must extend along the wall above the ledger and the horizontal leg extends over the top of the ledger).

Confirmation

The EarthCraft Technical Advisor will confirm installation of flashing during mid-construction review. Confirmation may occur during a field inspection or by a review of photo documentation provided by the builder.

Example

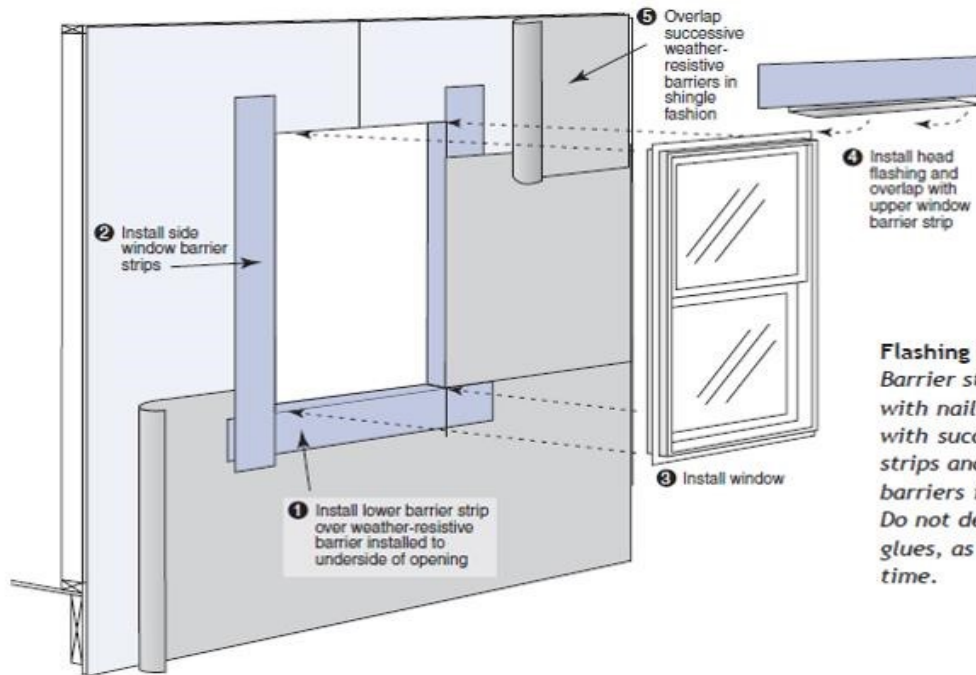

Flashing Detail

Barrier strips are attached with nails and overlapped with successive barrier strips and weather-resistant barriers in shingle fashion. Do not depend on tapes or glues, as they may fail over time.

DU 8 Install siding per manufacturer and industry recommendations (details below):

- **Maintain 1.5" clearance between wall siding and roof surface for wood siding, manufacturers' recommendation for composite products**

Purpose

Correctly installed siding reduces risk of improper water drainage or intrusion of water between siding and sheathing, which could result in structural damage.

Criteria

Terminate wall siding a minimum of a 1.5" above roof surface unless otherwise directed by product manufacturer installation specifications.

Verification

The EarthCraft Technical Advisor will visually confirm compliance of criteria during mid-construction inspection.

Example

Correct



Flashing installed properly between roof and exterior wall.

DU 9: Rigid, moisture-resistant backing material behind tubs and showers

Purpose

Moisture-resistant protection is needed behind showers and tubs to prevent moisture from seeping into the wall structure.

Criteria

Install cement board, fiberglass enhanced sheathing or equivalent moisture-resistant backing material directly behind tub and shower tile and panel assemblies with caulked joints. Install moisture-resistant backing material in accordance with manufacturer specifications.

Clarifications

Do not use paper-faced board as a backing material for tile. Moisture-resistant gypsum board may be used behind tile-backing material, e.g., green board, purple board.

Verification

The EarthCraft Technical Advisor will visually confirm compliance of criteria during the mid-construction inspection.

Example

Correct

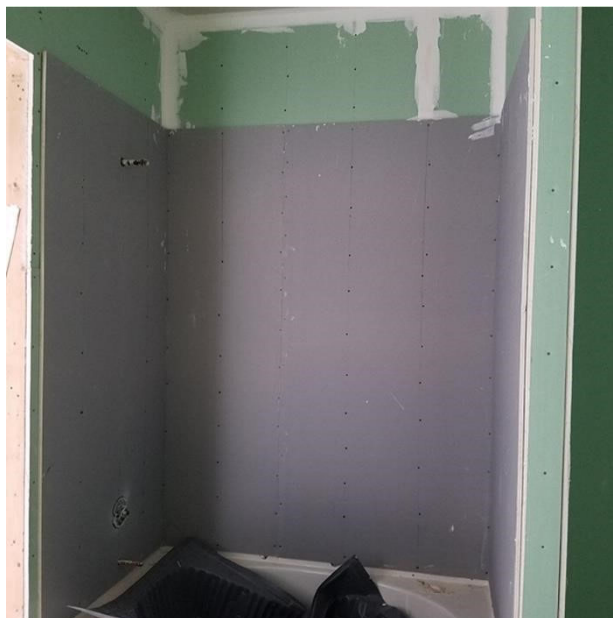

Install a moisture resistant backing material behind all bathtubs and showers

DU 10: Wall cavity insulation without a vapor retarder or kraft paper

Purpose

Installing a vapor retarder over vapor-permeable insulation on the interior of a wall does not ensure that moisture vapor in walls will be adequately controlled, regardless of which direction the paper is installed to face. Faced batts have the additional drawback of being difficult to install to grade I or II quality and difficult to inspect for proper installation around framing, plumbing, and electrical components.

Criteria

Install 100% of wall cavity batt insulation without a vapor retarder or kraft paper.

Clarifications

Blown applications of fiberglass/cellulose material that requires netting is allowed provided the netting material is ≥ 1.0 perm.

Verification

The EarthCraft Technical Advisor will visually confirm compliance of criteria during the mid-construction inspection.

Example



High Performance Building Envelope (BE)

Buildings account for about 40% of all energy use in the United States. EarthCraft encourages an energy efficient building envelope to reduce this impact. One of the key elements to any energy efficient home is constructing a proper building envelope by sealing for air leaks, properly installing insulation, and using high-quality windows and doors. The building envelope is the barrier that separates the home's conditioned space from unconditioned space or the outside. The building envelope consists of two parts – an air barrier and a thermal barrier (insulation) that must be both continuous and contiguous (touching each other). In a typical residence, the building envelope consists of the roof or ceiling, walls, windows, doors, and floor or foundation.

BE 1: Envelope leakage testing: ≤ 3 Air Changes per Hour at 50 pascals (ACH50) or ≤ 0.25 Envelope Leakage Ratio (ELR)

Purpose

Envelope leakage is a measure of the air tightness quality of the building envelope, an assessment of how much natural ventilation is supplied by air leakage, and envelope leakage test results may be used to assess energy losses resulting from uncontrolled air leakage. Envelope leakage allows air to enter the home from unknown sources that may contain air contaminants (e.g., moisture, pests, soil gases, dust, and other particles). It is preferred to build a tight home and bring in fresh air from known sources via mechanical ventilation.

Criteria

Envelope leakage testing results must be less than or equal to 3 ACH50 or 0.25 ELR

Definitions

- CFM50: The volume of air in cubic feet per minute moved through the fan to maintain a 50 Pa pressure difference between the house and outside.
- ACH50 = ACH50 is the number of times the air volume in a building changes per hour at 50 pascals of pressure.
 - $ACH50 = (CFM50 * 60) / \text{conditioned volume}$
- SFBE: Square footage of the building envelope. The sum of the foundation/floor, exterior walls, and ceiling areas.
- Envelope Leakage Ratio (ELR): The quotient of the CFM50 measurement divided by the square footage of the building envelope, or SFBE.
 - $ELR = CFM50 / SFBE$

Clarification

Floor area and volume must be calculated using RESNET standards for conditioned floor area and conditioned volume.

Verification

The EarthCraft Technical Advisor will diagnostically test compliance of criteria at the final inspection.

BE 2: Air seal where required by EarthCraft

All are required, as applicable to design:

- All gaps in exterior sheathing $\geq 1/4"$, including rim and band areas
- Cantilevered floors blocked at exterior wall, gaps $\geq 1/4"$ sealed
- All chases blocked and sealed (Ex. HVAC, fireplace, tubs, under stairs)
- All plumbing and electrical penetrations
- Sill and sole plates sealed to subfloor and foundation
- All other penetrations through subfloor/slab, framing and drywall
- Rough openings around exterior doors and windows
- HVAC Boots and mechanical ventilation fan penetrations through drywall and/or subfloor

Purpose

Air sealing is the process of reducing air infiltration and exfiltration of a home. Air leaks are a major cause of energy losses, moisture problems, poor indoor air quality, and discomfort.

Criteria

Gaps and holes should be sealed using an appropriate sealing material, e.g., caulk (fire-rated, silicon, etc.), spray foam, foam inserts. If gaps/holes are too large to seal with caulk or spray foam alone per manufacturer instructions, a rigid backing material (e.g., wood, drywall) should be used to cover the hole, with the edges of the backing material sealed with an appropriate air sealing material.

When sealing window/door rough openings with spray foam, low-expanding spray foam approved for use around windows and doors is preferred.

Verification

The EarthCraft Technical Advisor will visually confirm compliance of criteria during the mid-construction and final inspections.

Example

Refer to the 2020 Georgia Residential Energy Code Field Guide for details on air sealing:

<https://4553qr1wvuj43kndml31ma60-wpengine.netdna-ssl.com/wp-content/uploads/2019/09/GA-2020-Residential-Field-Guide.pdf>

BE 3: All recessed can lights must be airtight, gasketed and Insulation Contact (IC) rated in insulated ceilings

Purpose

If recessed lighting is installed incorrectly, it may contribute significantly to air leakage and compromise building integrity. If a light fixture will be in contact with insulation, the fixture must be IC-rated to prevent any the possibility of flame ignition.

Criteria

See above language and reference manufacturer's instructions for installation.

Confirmation

The EarthCraft Technical Advisor will visually confirm compliance of criteria during the mid-construction inspection.

Example

Correct



Can lights shall be sealed, IC-rated

BE 4: Insulate building components to meet EarthCraft requirements

Insulation R-value requirements are based on Climate Zone the project is located:

Climate Zone	Ceiling R-Value ^A	Wood Frame Wall R-value	Mass Wall R-Value ^C	Floor R-Value	Basement Wall R-Value ^C	Slab R-Value & Depth ^D	Crawl Space R-Value ^C
1	38	13	3/4	13	NA	NA	NA
2	38	13	4/6	13	NA	NA	NA
3	38	19 or 13+5 ^B	8/13	19	5/13	NA	5/13
4 (except Marine)	49	19 or 13+5 ^B	8/13	19	10/13	10, 2 ft	10/13
5 and Marine 4	49	19 or 13+5 ^B	13/17	30	15/19	10, 2 ft	15/19

A: When an air-impermeable insulation product is installed in contact with the roof decking R-20 is accepted
 B: "13+5", where the first number represents cavity insulation, the second continuous exterior insulation.
 C: "8/13", where the first number represents basement walls that have been insulated with a continuous insulation material, the second represents basement walls that have been framed and insulation installed between framing members.
 D: Indicates the R-value required at the slab edge

Purpose

Insulating homes to EarthCraft standards will ensure that each home features a well performing thermal envelope.

Criteria

See above language for minimum cavity and continuous insulation values

Clarifications

- Attic knee walls require minimum R-18 plus sealed attic-side air barrier (e.g., R-13 +R-5 rigid insulation, R-15 + R-3 rigid insulation, R-19 batt in 2x6 cavity with air barrier material).
- Roofline insulation may not be used in a vented attic.
- Framed floors over basement/crawlspace only require insulation if basement/crawlspace is outside of building envelope.
- If insulating a steel joist floor, R-6 continuous insulation must be installed in addition to floor insulation listed above.
- If insulating a steel studded wall or steel header, R-5 continuous insulation must be installed in addition to wall insulation listed above.
- Garage walls are considered exterior walls.
- Foundation walls require insulation if inside building thermal envelope.

- Flat ceiling insulation not installed to full depth (e.g., under attic platforms, over wall top plates at eaves, etc.) must be modeled at actual installed R-value but may not be modeled or installed less than R-21, and no more than 500 sq. ft. or 20% of the total insulated ceiling area, whichever is less, may be less than R-38 in Climate Zones 2 and 3 and R-49 in Climate Zone 4.
- Slabs greater than 12" below grade as measured from the top of the slab are not required to have insulation.
- Permanently install insulation to crawlspace walls and extend downward from the termite inspection strip to within 9" of the finished interior grade adjacent to the foundation wall.
- Provide a 3" inspection strip immediately below the floor joists to allow inspection for termites. (The inspection strip may be insulated with a removable section of insulation but is not required to be insulated.)
- Paper-faced batts may not be used (see DU 10)

Verification

The EarthCraft Technical Advisor will visually confirm compliance of criteria during mid-construction and final inspections.

BE 5: ANSI/RESNET/ICC 301-2014 Addendum F-2018 Normative Appendix A Grade I insulation installation quality based on insulation product used (floors, walls, and ceilings)

Purpose

Ensure proper installation of insulation materials and achieve Grade I quality based on material used.

Criteria

Install insulation per manufacturer's recommendations to achieve quality Grade I as specified by criteria set forth by RESNET. This is a requirement for all projects.

Additional Information

As will be noted throughout section BE 4, all insulation shall be installed to meet a Grade I quality, as defined in the Residential Energy Services Network (RESNET) Mortgage Industry National Home Energy Rating Systems (MINHERS), Continuous Maintenance Edition.

All current RESNET standards are available online at:

<https://www.resnet.us/about/standards/minhers/>

Insulation grading criteria for each product type is listed below. These criteria is based on:

- Standard ANSI/RESNET/ICC 301-2014 [Addendum F, Appendix A: Inspection Procedures for Insulation Grading and Assessment](#), dated July 1, 2019

"Minimum General Installation Requirements:

- Insulation shall be installed to manufacturers' recommendations.
- No air spaces shall be allowed between different insulation types or systems.
- Insulation shall be installed to the required density and thickness necessary to achieve the labeled R-Value.
- Insulation shall fill around obstructions including, but not limited to, framing, blocking, wiring, pipes, etc. without substantial gaps or voids."

Grade I Insulation Criteria

"Grade I (Minor Defects) Shall meet ASTM-specified installation requirements in the applicable standards C1015, C1320 and ASTM C1848, and shall meet the following appropriate material installation grading requirements:

Batt or Loose-fill Insulation

- When installing batt, or loose-fill insulation, no more than 2% of the total insulated area shall be compressed below the thickness required to attain the labeled R-Value or contain gaps or voids in the insulation.
- These areas shall not be compressed more than 3/4 inch of the specified insulation thickness in any given location.
- Voids extending from the interior to exterior of the intended insulation areas shall not be permitted.

Open-Cell Polyurethane Spray Foam Insulation (cavity not filled and not trimmed)

- When installing open-cell polyurethane spray foam the average of all thickness measurements shall be greater than the specified thickness required to obtain the specified R-Value.
- No more than 2% of the insulated area shall contain voids or be more than 3/4 inch below the specified thickness.
- The minimum installed thickness shall not be less than 1 inch below the specified thickness at any point. Voids extending from the interior to the exterior of the intended insulation areas shall not be permitted.

Open-Cell Polyurethane Spray Foam Insulation (cavity filled and trimmed)

- When installing open-cell polyurethane spray foam, no more than 2% of the total insulated area (cavity) shall be below the thickness required to attain the specified thickness or contain gaps or voids in the insulation.
- The minimum installed thickness shall not be less than 1/2 inch below the specified thickness at any point.
- Voids extending from the interior to exterior of the intended insulation areas shall not be permitted.

Closed-Cell Polyurethane Spray Foam

- When installing closed-cell polyurethane spray foam the average of all thickness measurements shall be greater than the specified thickness required to obtain the specified R-Value.
- No more than 2% of the insulated area shall contain voids or be greater than 1/2 inch less than the specified thickness.
- The minimum installed thickness shall not be less than 3/4 inch below the specified thickness at any point.
- Voids extending from the interior to exterior of the intended insulation areas shall not be

permitted.

Insulated Sheathing

- Insulated sheathing insulation installations meeting the minimum installation, application, and material requirements above.
- Voids exceeding 1/8" through interior to exterior of the intended insulation areas shall not be permitted.
- Joints and other gaps or separations in sheathing used as an air barrier, vapor retarder or drainage plane shall be taped or sealed."

Confirmation

The EarthCraft Technical Advisor will visually confirm compliance of criteria during the mid-construction and final inspections.

Examples

Correct



Incorrect



BE 6: Unconditioned attics (as applicable to project design):

- Insulation baffles at all soffit vents, trays, and attic access
- Loose-fill insulation R-value certificate and depth rulers installed 1 per 300 ft²
- Platforms allow for full-depth insulation below
- Attic access within conditioned space insulated to same R-value as surrounding attic
- Knee walls ≥ 1 ft tall insulated to R-18 with sealed attic side air barrier
- Knee walls < 1 ft tall fully covered to achieve same R-value as surrounding attic

Purpose

It is important to Insulate unconditioned attic spaces correctly because they are a potential source of significant heat loss and gain. This item focuses on installing attic insulation to the correct depth (R-value) at differing attic locations and ensuring the insulation is not susceptible to wind-washing or convective losses.

Criteria

See above requirements for reference.

Confirmation

The Technical Advisor will visually verify compliance during the mid-construction and final inspections.

Examples

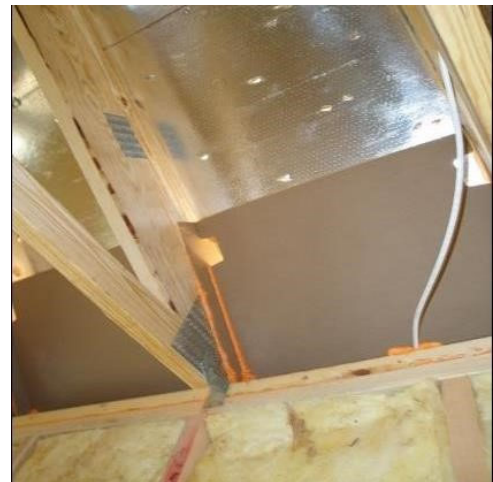

BE 7: Window and skylight U-factor and Solar Heat Gain Coefficient (SHGC) meets or exceeds EarthCraft standards (chart below):

Climate Zone	Fenestration U-factor	Glazed Fenestration SHGC	Skylight U-factor
1	NR	0.25	0.75
2	0.32	0.25	0.65
3	0.32	0.25	0.55
4 (except Marine)	0.32	0.27	0.55
5 and Marine 4	0.30	NR	0.55

Purpose

The U-Factor determines how well your windows insulate your home and the Solar Heat Gain Coefficient (SHGC) is a measure of how much solar-radiated heat energy can transfer through a window. To maximize energy efficiency, window and skylights must be carefully selected to comply with the IECC U-factor and SHGC specifications.

Criteria

See above language and reference the IECC 2015 with Georgia Amendments for further specification details.

Clarifications

- The above chart references the 2015 IECC with Georgia Amendments. Where local code is more stringent defer to the higher performing U-factor or SHGC.
- Up to 15 square feet of glazing or decorative glass may be exempt from this requirement.
- Floor area must be calculated using RESNET standards for conditioned floor area.

Confirmation

- The builder must present documentation demonstrating compliance of criteria to the EarthCraft Technical Advisor prior to the mid-construction inspection.
- The EarthCraft Technical Advisor will review documentation provided by the builder for compliance of criteria and verify installation during the mid-construction inspection.

PERF 1: Confirmed HERS Index ≤ 50

Purpose

Home energy modeling provides many benefits to the builder and homeowner. For example, energy models provide annual energy usage estimates, assigns the home a HERS Index Score that can be compared with other homes and can determine the home's compliance with a host of programs, standards, and codes. Home energy modeling also allows the builder and homeowner to pick and choose which appliances, lighting, HVAC equipment, insulation values, etc. to install in the home instead of following a prescriptive building envelope and HVAC systems list. Energy modeling affords this flexibility while ensuring the home meets the Performance Badge's energy efficiency goal of a HERS Index ≤ 50 .

Criteria

Home energy model based on actual construction must demonstrate a confirmed HERS Rating Index that is equal to or less than 50.

Confirmation

- The builder must present documentation demonstrating compliance of criteria to the EarthCraft Technical Advisor at mid-construction.
- The EarthCraft Technical Advisor will develop an energy model in accordance with RESNET modeling criteria and confirm compliance of criteria at mid-construction and final inspections.

PERF 2 Building envelope meets or exceeds local jurisdiction requirements

Purpose

To allow for flexibility with energy modeling requirements outlined in PERF 1, projects are allowed to meet local State/city/county requirements for building envelope insulation levels (R-value) where they differ from the requirements outlined in BE 4 and BE 7.

Criteria

Comply with current State/city/county energy code requirements for building insulation R-values and fenestration U-factor.

Confirmation

- The builder must present documentation demonstrating compliance of criteria to the EarthCraft Technical Advisor at mid-construction.
- The EarthCraft Technical Advisor will develop an energy model in accordance with RESNET modeling criteria and confirm compliance of criteria at mid-construction and final inspections.

EL 1: All-electric home with the following

- **Solar-ready electrical panel**
- **One (1) electric vehicle charging station**
- **Electric air source heat pump or ground source heat pump HVAC systems meeting ES 2 and ES 3**
- **Electric water heater equipment meeting PI 1.**
- **No utility gas line service for any secondary appliances (fireplaces, outdoor cooking, etc.)**

Purpose

Reduce operational carbon emissions in the building by removing permanent sources of fossil fuel-using appliances.

Criteria

Design and construct an all-electric home that is equipped with the infrastructure necessary for the installation of solar panels either at the time of construction or to be installed in the future. At a minimum, the home must meet the following:

- Heat pump HVAC system(s) for heating and cooling
- Electric water heating
- At least one (1) electric vehicle charging station/outlet
- Electric cooking (oven and range)
- No gas lines installed for indoor heating or cooking, or outdoor heating or cooking
- No gas fireplaces or space heating
- Electrical panel minimum requirements:
 - Minimum 200-amp service panel
 - Install conduit in the attic/roofline for connection to future solar panels
 - Install conduit to where future connected equipment (inverters or meters) will be installed
 - Refer to sections 690.1 and 705.12 of the National Electric Code
 - Comply with all state and local codes regarding solar panel wiring and battery storage requirements

Additional Information

The National Fire Protection Association (NFPA) 70: National Electrical Code may be downloaded at:

- <https://www.nfpa.org/codes-and-standards/all-codes-and-standards/list-of-codes-and-standards/detail?code=70>

Confirmation

- The builder must present documentation demonstrating compliance of criteria to the EarthCraft Technical Advisor during the design review meeting and mid-construction inspection(s).
- The EarthCraft Technical Advisor will confirm compliance of criteria at mid-construction and final inspections.

EL 2: Solar ready building design and construction

- Solar orientation optimization of roof
- Rooftop constructed to bear weight of solar panels

Purpose

Ensure that the building roof can support future rooftop solar and that it's orientation is optimized for solar power generation.

Criteria

Work with a qualified solar contractor to determine optimal roof orientation and slope while taking into account shading produced by trees and buildings on neighboring lots and local jurisdiction requirements on a home's placement on a lot, building height, and/or other design requirements.

Ensure that the roof can support the weight of photovoltaic (PV) equipment, between 3-6 pounds per square foot.

If the roof installation carries a warranty, ensure the warranty includes language involving solar installations.

If necessary, analyze rooftop wind loads to ensure the roof structure and PV equipment are rated to withstand anticipated wind loads.

Confirmation

- The builder must present documentation demonstrating compliance of criteria to the EarthCraft Technical Advisor at mid-construction.
- The EarthCraft Technical Advisor will confirm compliance of criteria at mid-construction and final inspections.

EL 3: Energy modeling to confirm home is designed to be net-zero or net-positive post-occupancy with properly sized solar panels

Purpose

Complete preliminary energy modeling on home to determine baseload electrical needs may be met by appropriately sized solar panels installed on the roof or on the property.

Criteria

The Technical Advisor shall conduct preliminary energy modeling to determine if the home can achieve net-zero or net-positive energy consumption post-occupancy with properly sized solar panels.

Clarification

- Energy modeling for solar panels is not required to be a confirmed HERS model, but it must be conducted using an appropriate industry software for sizing and designing residential solar panels
- House baseline energy consumption must be based on the building design, building envelope components, and worst-case appliances that include planned secondary appliances such as wine coolers or supplemental freezers.

Confirmation

- The builder must present documentation demonstrating compliance of criteria to the EarthCraft Technical Advisor at mid-construction.
- The EarthCraft Technical Advisor will confirm compliance of criteria at mid-construction and final inspections.

Energy Efficient HVAC Systems (ES)

Buildings account for about 40% of all energy use in the United States. Constructing an energy efficient home provides variety of benefits to both the occupants and to the environment. Using less energy reduces the need to extract natural resources, reduces air pollution and eases the strain on our water resources. EarthCraft encourages the use of energy efficient HVAC systems to reduce this impact. Once the building envelope has been designed, evaluating heating and cooling systems, ventilation, and domestic water heating using the house-as-a-system approach is critical to achieving a high-performance home.

In addition, an energy efficient home not only provides savings on utility bills to residents but also improves their comfort and health. Comfort is a function of air temperature, relative humidity and radiant heating and cooling, all of which are impacted by the energy systems used in a home.

ES 1: Size and select all HVAC equipment in accordance with ACCA Manuals J and S

Purpose

Properly sizing and selecting HVAC equipment by accounting for heat loss/gain throughout the year based on factors such as a building's geographic location, orientation of windows and doors, envelope tightness, outdoor air ventilation, duct leakage, and lights and appliances allows an HVAC contractor to provide a system that can properly meet design and efficiency goals.

Criteria

Size and select all HVAC equipment in accordance with the Air Conditioning Contractors of America (ACCA) Manuals J and S. Load calculation must coordinate with accurate construction specifications and plans for the project as well as as-built conditions.

Complete load calculation with accredited ACCA Manual J 8th Edition Full Residential Load Calculation software. [Reference ACCA for a list of approved software.](#)

OR

Load calculation must be stamped by a Professional Engineer along with a signed "Professional Engineer Load Calculation Affidavit".

The following criteria should be met for all equipment sizing:

- Based on actual house orientation
- Load calculation must be based on actual home orientation as constructed
- Use most current ASHRAE Handbook of Fundamentals Climate Design Information for outdoor design temperatures
- Design heating and cooling systems using the annual outdoor design conditions as defined in the most current ASHRAE Handbook of Fundamentals
- The 99% design conditions must be used to size heating equipment
- The 1% design conditions must be used to size cooling equipment

Clarifications

The abridged edition of ACCA Manual J is not an acceptable methodology within the EarthCraft program.

Multispeed or multistage equipment may have OEM nominal size increments of one ton. Therefore, the use of multispeed or multistage equipment can provide extra flexibility to meet the equipment sizing requirements. The equipment oversizing limit shall be based on the largest capacity of the unit.

Floor area must be calculated using RESNET standards for conditioned floor area

Example #1

Equipment sizing selection:

If the load calculation specifies a total sensible load of 36,000 Btuh, the 115% oversizing limit allows for using up to 41,400 Btuh: $36,000 \times 1.15 = 41,400 \text{ Btuh}$

If Manufacturer X makes a nominal 3 ton AC unit and a nominal 4 ton AC unit, but no sizes in between, then Builder Y may install the 4 ton unit made by Manufacturer X as long the nominal 3 ton unit has insufficient capacity (i.e. total capacity of $36,000 \times 0.95 = 34,200 \text{ Btuh}$).

Alternately, if Builder Y wanted to use a heat pump from Manufacturer Z and Manufacturer Z offers nominal 3 ton (33,000 Btuh), 3.5 ton (39,400 Btuh) and 4 ton heat pump (45,800 Btuh), then Builder Y must install the nominal 3.5 ton unit by Manufacturer Z because the unit is between the Manual J specification and the climate zone 3, 115% oversizing limit set Manual S.

Additional Resources

- Air Conditioning Contractors of America, see [here](#).
- To download the EarthCraft Professional Engineer Load Calculation Affidavit, see [here](#).

Confirmation

- The EarthCraft Builder shall notify their HVAC contractor of the requirements for meeting Manual J and S requirements, and the Builder must present documentation demonstrating compliance of criteria to the EarthCraft Technical Advisor.
- The Technical Advisor will review the load calculations for accuracy and completeness at mid-construction review.

ES 2: Heating equipment efficiency meets EarthCraft requirements (details below):

- Ducted furnace(s) and/or boiler(s) >95% AFUE, sealed combustion
- Ducted heat pump(s): ≥9 HSPF or ≥7.65 HSPF2
- Ductless system ≥10 HSPF or ≥9 HSPF2

Purpose

Furnaces with a rated Annual Fuel Utilization Efficiency (AFUE) of ≥90% are equipped with a sealed combustion chamber that prevents provides combustion air from a known location. Sealed combustion chambers have the added safety benefit of being sealed from external conditions, thus reducing the risk of flame roll out and back drafting of combustion products.

Criteria

Furnace(s) ≥95% AFUE and within 40% of load calculation

- All heating equipment must be ≥95% AFUE for gas combustion furnaces. All furnaces must be sized within 40% of the heating load as determined by the load calculation. If the required fan speed cannot be provided by a smaller unit, a furnace may be more than 40% oversized.

Ducted heat pump(s): ≥9 HSPF or ≥7.65 HSPF2

- Heat pumps in Climate Zones 2 and 3 must be within 15% of the load calculation or the next available size. Heat pumps in Climate Zone 4 must be within 25% of the load calculation or the next available size.

Ductless system ≥10 HSPF or ≥9 HSPF2

Confirmation

- The builder must present documentation demonstrating compliance of criteria to the EarthCraft Technical Advisor at the mid-construction inspection
- The EarthCraft Technical Advisor will review documentation provided by the builder for compliance of criteria and will visually confirm compliance of criteria at final inspection.

ES 3: Cooling equipment efficiency (Details below):

- Ducted split system ≥ 16 SEER/ ≥ 15.2 SEER2
- Ductless system ≥ 19 SEER(SEER2)
- Ducted package unit ≥ 12.5 EER/ ≥ 11.86 EER2
- Ducted geothermal heat pump(s):
 - Closed loop water-to-air: ≥ 17.1 EER/ ≥ 16.3 EER2; 3.6 COP
 - Open loop water-to-air: ≥ 21.1 EER/ ≥ 20.1 EER2; 4.1 COP
 - Closed loop water-to-water: ≥ 16.1 EER/ ≥ 15.3 EER2; 3.1 COP
 - Open loop water-to-water: ≥ 20.1 EER/ ≥ 19.1 EER2; 3.5 COP

Purpose

A high-efficiency system will deliver more comfort, better moisture control and quiet operation, while using less energy than a less efficient system.

Criteria

Purchase and install equipment meeting the minimum efficiency standards listed above. Equipment purchased and installed after January 1, 2023 will be required to meet SEER2/EER2 ratings.

Additional Resources

A list of qualified products can be found [here](#).

Confirmation

- The builder must submit documentation demonstrating compliance of criteria to the EarthCraft Technical Advisor at the mid-construction review.
- The EarthCraft Technical Advisor will review documentation provided by the builder for compliance of criteria and will visually confirm compliance of criteria at mid-construction and final inspections.

ES 4: Programmable thermostat with adaptive recovery capability

Purpose

Programmable thermostats can be used to suit the needs of the occupants in the cooling or heating seasons during periods when a building is occupied and when it is not. Proper use of programmable thermostats can assist occupants with reducing energy consumption by allowing them to program a schedule that reduces runtime.

Criteria

All heating and cooling equipment must have a programmable indoor thermostat or thermostat installed according to the manufacturer's specifications. Building occupants should be provided a copy of the thermostat user manual as education for proper use and maintenance of thermostats.

Confirmation

The EarthCraft Technical Advisor will visually confirm compliance of criteria at final inspection.

ES 5: No HVAC equipment or ductwork located in garage

Purpose

Garages, including attached and carports, are known sources of indoor air contaminants and must be fully separated from conditioned space. To ensure that HVAC systems for the living space, including equipment and ductwork, are fully separated from garages they cannot be installed these spaces and cannot provide conditioned air to them.

Criteria

Do not located HVAC equipment or ductwork inside garage spaces. Do not design distribution equipment to supply conditioned air to garage spaces.

Clarification

HVAC equipment and ductwork are considered separate from garage spaces if they are separated from the garage by $\geq 1/4$ " drywall that has been air sealed at all penetrations and connections. If equipment and/or ductwork is located in a closet that is accessible from the garage, the closet must be air sealed to separate the closet from the garage and the door should be gasketed on all sides.

Confirmation

Technical Advisor will visually confirm that HVAC equipment and ductwork is separated from garage spaces during mid-construction inspection(s). If necessary, Technical Advisor shall complete verification that the entire system is separated at the final inspection.

Examples



Do not install HVAC equipment or ductwork that serves the living space within garage.

ES 6 If installed, HVAC ductwork meets EarthCraft requirements for installation, insulation, and air sealing (details below):

- Air seal ductwork using mastic/mastic tape:
 - Plenum seals
 - Collars to plenum
 - Collars and boots to flex liner
 - Seams in boots and wyes
 - All flex liner to wye connections
 - Air handler unit seams
- Insulate ductwork to standards set by EarthCraft:
 - Unconditioned attic: $\geq R-8$
 - All other spaces: $\geq R-6$
- HVAC ductwork installation meets EarthCraft standards (details below):
 - Fully duct all supply and return ducts
 - No ducts in exterior walls or vaulted ceilings
 - Install rigid ducts, or pull all flex ducts with no pinches and ≥ 1 " support strapping at intervals $\leq 5'$
 - Ducts suspended above attic floor trusses to allow for full depth of attic floor insulation
- HVAC system and ductwork is protected during construction (details below):
 - Protect all ceiling/floor registers until construction is complete
 - Protect HVAC fan until construction is completed
 - Pleated filter installed during construction

Purpose

Poorly sealed ductwork allows conditioned air to leak both inside and outside the building envelope, reducing system efficiency. Ductwork insulation controls heat transfer and reducing the risk of condensation on ductwork by reducing the temperature difference between air within the ductwork and air surrounding the exterior.

By keeping construction dust and debris out of ductwork and the HVAC equipment throughout the duration of construction IAQ goals and system integrity are maintained.

Criteria

Seal all seams, joints and connections in forced-air delivery systems using mastic paste or Butyl rubber backed foil tape (mastic tape), including but not limited to:

- Supply and return ducts

- Supply and return plenums
- Duct-to-plenum connection
- Y-splits, butt joints and boot connections
- Outdoor air intakes
- Air handler condensate and refrigerant line penetration, wire penetrations and unused holes in the air handler cabinet

Clarifications

- Duct tape is not a suitable sealant for ducts. Foil tape without additional sealants may only be used for sealing leaks at the air handler's removable access panels and at filter access panels. Duct boots may be sealed to floor, wall, or ceiling using caulk, foam, mastic tape, or mastic paste.
- Wrap mastic tape at least two times around duct seam touching at least 1 1/2" of duct inner liner and metal collar or sleeve.
- Assemble duct board using code-approved foil tape and coat seams with layer of mastic paste covering seams by 1.5" on both sides and as thick as a nickel.

Confirmation

- The EarthCraft Technical Advisor will visually confirm compliance of criteria at mid-construction and final inspections.

Examples of proper ductwork sealing:

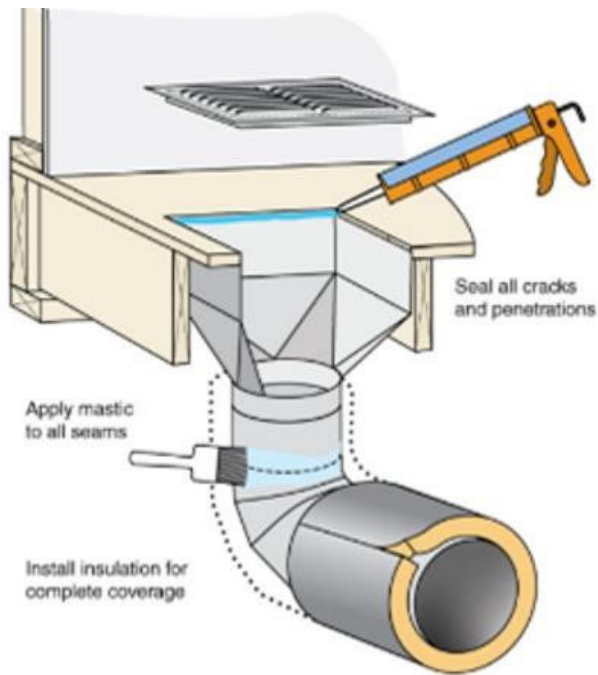

Air seal all seams in ductwork, including ductwork seams, duct-to-boot connections, and gaps where duct boots connect to the subfloor/drywall. Appropriate air sealing materials for ductwork are mastic/mastic tape. Appropriate materials for air sealing boots to subfloor/drywall include mastic, caulk, and/or foam

Air seal all gaps and seams at HVAC equipment, including manufactured seams, penetrations for wires and refrigerant lines, and duct plenums. Appropriate air sealing materials are mastic/mastic tape.

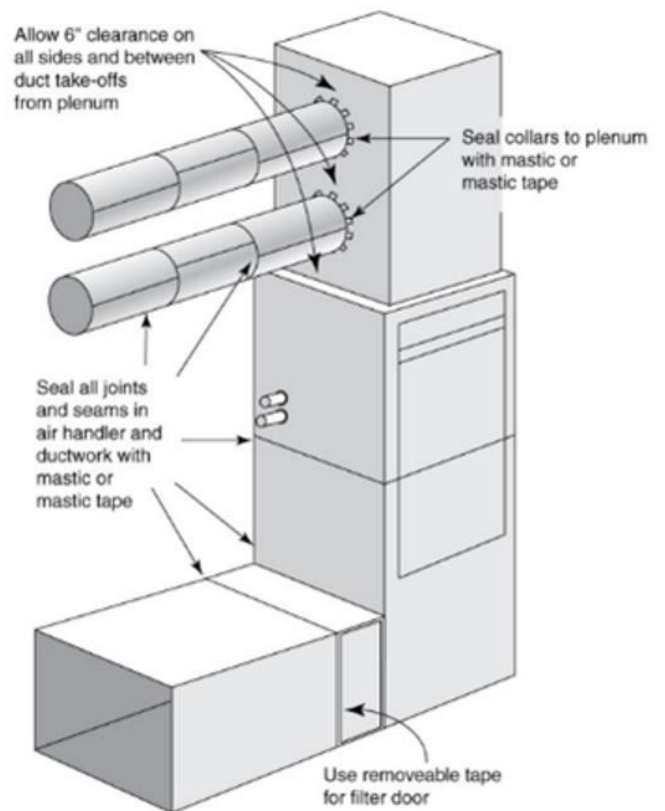

Example of proper and improper ductwork installation:

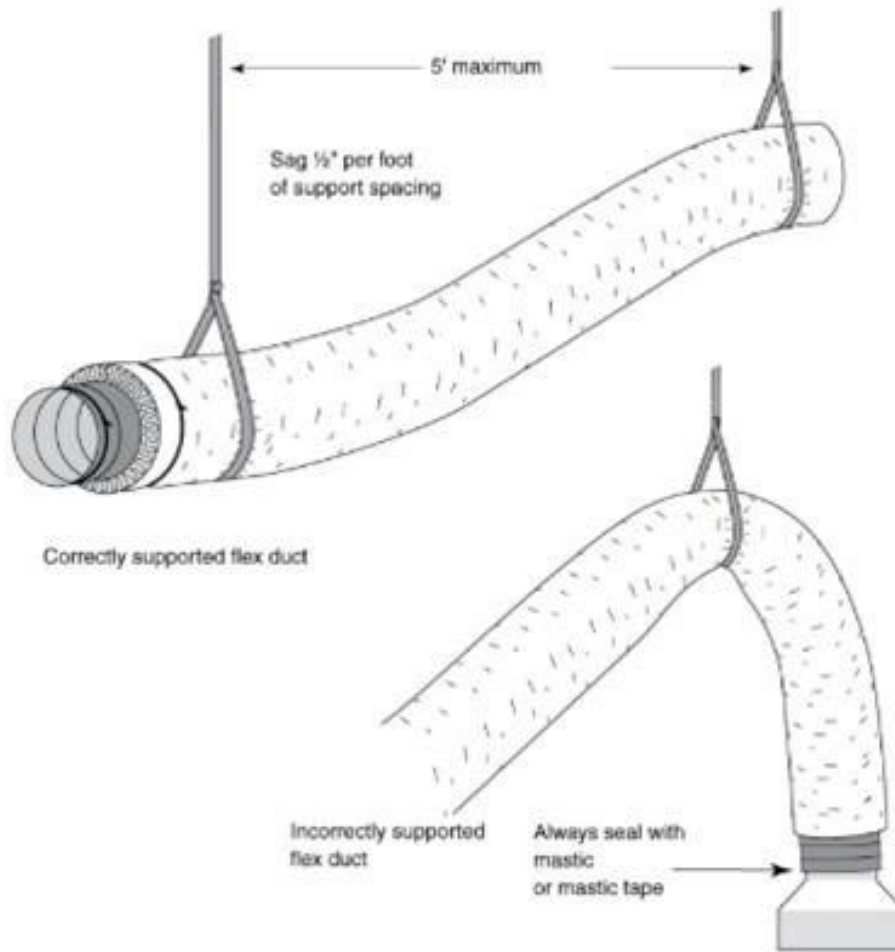

Properly support all flexible ductwork with

≥1" strapping at lengths ≤5'.

ES 7: Filters (Details below):

- Filter easily accessible for occupant
- Access panel includes gasket and fits snugly
- At final, all filters \geq MERV 8

Purpose

Filters should be easily accessible so that occupants may change them when needed, this increases the likelihood for good indoor air quality. A snug-fitting gasket door prevents air leakage during system operation.

Higher rated air filters are more efficient at trapping particulate matter from indoor air. HVAC filters should have a Minimum Efficiency Reporting Value (MERV) of 8 to meet EarthCraft requirements.

Criteria

Filter easily accessible for occupant

- Design system so that the filter is easily accessed by occupants. Easily accessed includes locating the filter in a location that is reasonable for an individual to reach and is not obscured in any way that would prevent an individual from fully pulling out a filter to remove it.

Access panel includes gasket and fits snugly

- Eliminate filter bypass between the filter and filter rack by sealing the filter access panel to prevent air leakage and ensuring it fits snugly against the exposed edge of the installed filter when closed.

At final, all filters are \geq MERV 8

- Install an HVAC filter with \geq MERV 8 (according to ASHRAE 52.2) on all HVAC systems. HVAC design and installation must account for airflow based on filter selection.

Clarifications

- Filters perform best when the filter rack design includes flexible, airtight (e.g., closed-cell foam) gasket material on the downstream side of the filter and friction fit or spring clips installed on the upstream side of the filter.

- Non-standard efficiency ratings for filters (e.g., 3M's Microparticle Performance Rating (MPR)) and filters that do not have a MERV rating (e.g., electrostatic filters) need prior approval by EarthCraft.
- HVAC system design and installation must be designed to accommodate the criteria.

Confirmation

The EarthCraft Technical Advisor will visually confirm compliance of criteria at mid-construction and final inspections.

ES 8: If applicable, test duct leakage based on floor area served (Details below):

- Leakage to outside $\leq 3\%$. Not required if ducts are located 100% in conditioned space
- Total leakage $\leq 4\%$ at final

Purpose

The duct leakage test is a diagnostic tool designed to measure the air tightness of heating and air conditioning duct systems and to identify air leakage locations. Tighter HVAC distribution systems more effectively deliver conditioned air throughout a home and ensure comfort goals are met.

Criteria

Leakage to outside $\leq 3\%$. Not required if ducts are located 100% in conditioned space.

- Duct leakage test result for leakage to outside shall be $\leq 3\%$ of floor area served. The leakage to outside test is not required if 100% of ductwork, including the mechanical equipment, are located within conditioned space.

Total leakage $\leq 4\%$ at final

- Duct leakage test result for total leakage shall be $\leq 4\%$ for all projects.
- If any portion of the distribution system, including the mechanical equipment, is located outside of conditioned space then the total leakage test shall be completed during the final inspection.

The calculation for determining percent duct leakage is:

$$\text{Percent (\%)} \text{ Duct Leakage} = (\text{CFM}_{25} \div \text{floor area served (ft}^2\text{)} \times 100)$$

Where: Percent Duct Leakage may be applied to Leakage to Outside and Total Leakage CFM_{25} is the measured duct leakage at 25 pa pressure difference between the ductwork and exterior.

Floor area served is the area of conditioned space served by a single system.

Clarifications

- The leakage to outside and total leakage duct test applies to all ducted HVAC systems. HVAC systems designed and installed to operate without distribution systems (ductless systems) are exempt from this requirement.
- Floor area must be calculated using RESNET standards for conditioned floor area.

Confirmation

The EarthCraft Technical Advisor will diagnostically test compliance during mid-construction and/or final inspections, as applicable to project design.

PERF 3: Heating and cooling equipment meets or exceeds Department of Energy Standards

Purpose

To allow for flexibility with energy modeling requirements outlined in PERF 1, projects are allowed to meet US Department of Energy requirements for building envelope insulation levels (R-value) where they differ from the requirements outlined in ES 2 and ES 3.

Criteria

Comply with current Department of Energy regional appliance efficiency requirements for building insulation R-values and fenestration U-factor.

Clarification

- If gas heating equipment will be used it must be sealed combustion.

Confirmation

- The builder must present documentation demonstrating compliance of criteria to the EarthCraft Technical Advisor at mid-construction.
- The EarthCraft Technical Advisor will develop an energy model in accordance with RESNET modeling criteria and confirm compliance of criteria at mid-construction and final inspections.

CMFRT 1: If designed, improved duct design (Details below):

- **Install ducts per ACCA Manual D duct design**
- **Measure and balance airflow per ACCA Manual B**
- **Verify supply and return duct static pressure**

Purpose

Improved duct design ensures that HVAC performance and comfort goals are met for a project. A Manual D duct design allows the HVAC contractor to design the distribution system in a way that delivers adequate conditioned air to each room without over pressurizing or depressurizing other areas.

Criteria

Design and install HVAC ductwork in accordance with an ACCA Manual D. A list of approved Manual D software may be found [here](#).

Confirmation

- The EarthCraft Builder will provide the Technical Advisor with the balance and pressure test results prior to submitting project for certification.
- The Technical Advisor will review the Manual D duct design prior to the mid-construction inspection. During the mid-construction inspection, the TA will visually verify that the as built duct design matches the Manual D design.

CMFRT 2: HVAC system (equipment and ductwork) installed 100% within conditioned space

Purpose

To ensure system efficiency and indoor comfort goals are met, install all HVAC equipment within conditioned space.

Criteria

Projects may use a variety of strategies that meet the intent of this credit, including:

- Install equipment and ductwork within a conditioned attic that has insulation installed along the roofline
- Install equipment and ductwork within a closed crawlspace
- Install equipment and ductwork completely within the building envelop, such as in a utility closet and in band areas between floors
- Install ductless HVAC equipment
- Other options accepted by the 2015 or later versions of the IECC that are considered ductwork within conditioned space

Confirmation

- The EarthCraft Builder will provide the Technical Advisor with the planned HVAC design and installation prior to the mid-construction inspection
- The EarthCraft Technical Advisor will verify the HVAC equipment and ductwork installation during the mid-construction and final inspections.

CMFRT 3: Verify proper refrigerant charge and total system airflow within 20% of design air flow

Purpose

Verifying correct refrigerant charge helps ensure that the equipment operates at maximum efficiency and decreases the likelihood of premature equipment failure.

Criteria

- Perform refrigerant charge test to ensure appropriate charge for HVAC equipment with subcooling deviation $\pm 3^{\circ}\text{F}$ or superheat deviation $\pm 5^{\circ}\text{F}$.
- Perform system airflow test using a flow hood, anemometer or other EarthCraft approved equivalent to ensure total system airflow is within 20% of the design airflow.

Clarifications

This requirement may be met by methods according to ACCA 5 QI-2007:

- Superheat method test measurement within 5% of the manufacturer-recommended charge
- Subcooling method test measurement within 3% of the manufacturer-recommended charge
- Other equivalent method/tolerance approved by the equipment manufacturer

Geothermal heat pumps, mini-split heat pumps and hermetically sealed factory-charged stems may not be appropriate for standard subcooling or superheat refrigerant charge testing. To accommodate these system types, an OEM (original equipment manufacturer) test procedure may be used and documented.

Confirmation

Refrigerant Charge

- The builder must submit documentation demonstrating compliance of criteria to the EarthCraft Technical Advisor prior to submitting the project for certification
- The EarthCraft Technical Advisor will review documentation provided by the builder for compliance of criteria.

Total System Airflow

- The EarthCraft Technical Advisor will diagnostically test compliance of criteria at the final inspection or be present to observe the test being completed by the HVAC contractor and confirm test results comply with criteria.

CMFRT 4: If ducted system installed, measure pressure differential ≤ 3 Pa

Purpose

This is to ensure that there will not be a significant pressure difference in separate rooms of the house. Pressure differentials can result in poor system airflow, which may cause damage to the HVAC system and impact indoor air quality by introducing contaminants for outside the building envelope.

Criteria

Design HVAC system to operate at balanced system pressures by providing multiple returns or by installing return air pathways for rooms that can be separated from the central return via door closures.

Confirmation

The EarthCraft Technical Advisor will visually confirm compliance of criteria at the mid-construction inspection and will diagnostically test compliance of criteria at the final inspection.

Indoor Air Quality (IAQ)

The average American spends over 90% of their time indoors, so creating a healthy and comfortable indoor environment is an important issue for any resident, especially those who are sensitive to poor air quality. Children, seniors, and individuals with respiratory problems and compromised immune systems may suffer more from indoor air quality problems. EarthCraft Builders can improve the health of a home by installing materials with fewer pollutants, flushing any pollutants out through proper ventilation, and controlling moisture to eliminate mold growth.

The Indoor Air Quality section consists of items that aim to reduce the presence of pollutants and contaminant in the air inside a home. Reducing or eliminating the presence of manmade pollutants such as volatile organic compounds or natural occurring carcinogens such as radon leads to a healthier environment for occupants.

IAQ 1: Provide whole building and local exhaust ventilation based on ASHRAE 62.2-2019 Ventilation and Acceptable Indoor Air Quality in Residential Buildings:

- Include whole building ventilation sizing in Manual J calculations
- Install labeled, accessible whole building ventilation controls
- Verify whole building ventilation airflow cubic feet per minute (CFM)
- Select a whole building ventilation design (choose one):
 - Balanced system
 - Supply system with \geq MERV 4 filter prior to outdoor air entering living space or HVAC unit
 - If central fan integrated system is used, HVAC system must be equipped with variable speed motor
- Vent all full bathrooms with ENERGY STAR \geq 50 CFM on-demand exhaust fan to exterior
 - Bath fans ducted using prescriptive design based on ASHRAE 62.2-2019 or measure airflow CFM at final
- Vent all kitchens with \geq 100 CFM on-demand range hood to exterior
 - Range fan ducted using prescriptive design based on ASHRAE 62.2-2019 or measure airflow CFM at final.
 - If range hood capable of \geq 400 CFM, install make-up air to meet IRC 2021 requirements

Purpose

Whole-house ventilation introduces fresh air into living spaces to dilute pollutants that cannot be removed completely through spot ventilation and/or filtration, thus providing for a healthy indoor environment.

Criteria

Install a whole-building mechanical ventilation system and mechanical exhaust systems that are designed to meet the air flow requirements of ASHRAE 62.2-2016.

The whole building air flow may be calculated based on Section 4.1.1 Total Ventilation

Rate:
$$Q_{tot} = 0.03A_{floor} + 7.5(N_{br} + 1)$$

Where:

where

Q_{tot} = total required ventilation rate, cfm

A_{floor} = dwelling-unit floor area, ft²

N_{br} = number of bedrooms (not to be less than 1)

OR

Projects may use Table 4.1a to determine minimum cfm for whole building ventilation

TABLE 4.1a (I-P) Ventilation Air Requirements, cfm

Floor Area, ft ²	Bedrooms				
	1	2	3	4	5
<500	30	38	45	53	60
501–1000	45	53	60	68	75
1001–1500	60	68	75	83	90
1501–2000	75	83	90	98	105
2001–2500	90	98	105	113	120
2501–3000	105	113	120	128	135
3001–3500	120	128	135	143	150
3501–4000	135	143	150	158	165
4001–4500	150	158	165	173	180
4501–5000	165	173	180	188	195

Local exhaust system airflow cfm may be verified via a field measurement completed during the final inspection, or by designing and installing the distribution system based on the Prescriptive Duct Sizing Table:

TABLE 5.3 Prescriptive Duct Sizing

Duct Type	Flex Duct								Smooth Duct							
Fan Airflow Rating, cfm @ 0.25 in. of water (L/s @ 62.5 Pa)	50 (25)	80 (40)	100 (50)	125 (65)	150 (75)	200 (100)	250 (125)	300 (150)	50 (25)	80 (40)	100 (50)	125 (65)	150 (75)	200 (100)	250 (125)	300 (150)
Diameter ^a , in. (mm)	Maximum Length ^{b,c,d} , ft (m)															
3 (75)	×	×	×	×	×	×	×	×	5 (2)	×	×	×	×	×	×	×
4 (100)	56 (17)	4 (1)	×	×	×	×	×	×	114 (35)	31 (9)	10 (3)	×	×	×	×	×
5 (125)	NL	81 (25)	42 (9)	16 (5)	2 (0.6)	×	×	×	NL	152 (46)	91 (28)	51 (16)	28 (9)	4 (1)	×	×
6 (150)	NL	NL	158 (48)	91 (28)	55 (17)	18 (5)	1 (0.3)	×	NL	NL	NL	168 (51)	112 (34)	53 (16)	25 (8)	9 (3)
7 (175)	NL	NL	NL	NL	161 (49)	78 (24)	40 (12)	19 (6)	NL	NL	NL	NL	NL	148 (45)	88 (27)	54 (16)
8 (200) and above	NL	NL	NL	NL	NL	189 (58)	111 (34)	69 (21)	NL	NL	NL	NL	NL	NL	198 (60)	133 (41)

a. For noncircular ducts, calculate the diameter as four times the cross-sectional area divided by the perimeter.
 b. This table assumes no elbows. Deduct 15 ft (5 m) of allowable duct length for each elbow.
 c. NL = no limit on duct length of this size.
 d. × = not allowed; any length of duct of this size with assumed turns and fitting will exceed the rated pressure drop.

Confirmation

The HVAC Manual J Load Calculation shall include whole building ventilation cfm based on the calculations in ASHRAE 62.2-2016. The Technical Advisor will review the Manual J report to verify system has been designed for ventilation airflow. At final, Technical Advisor shall field verify that installed ventilation airflow cfm meets the minimum continuous airflow required.

Note:

- Projects may design whole building ventilation cfm using the infiltration credit in ASHRAE 62.2-2019. Technical Advisor shall review Manual J input for reasonableness, and at final shall field verify actual building envelope infiltration and ventilation airflow cfm. If necessary, whole building ventilation shall be field adjusted to comply with ASHRAE 62.2019.
- Projects using the Prescriptive Duct Sizing Table for local exhaust shall document compliance with photo documentation capturing ≥75% of the distribution system

IAQ 2: Carbon monoxide detector (one per sleeping area, hard wired with battery back-up)

Purpose

Carbon monoxide poisoning is a significant health threat to building occupants can result in long-term neurologic or cardiovascular complications if conditions are not remedied. Due to the possibility of combustion appliances being introduced into the home after construction, CO monitors should be installed even if the house has no attached garage, fireplace or combustion appliances installed within or adjacent to conditioned space.

Criteria

Install one carbon monoxide (CO) detector per floor. If bedrooms are on the floor, install the CO detector in a central location near all bedrooms. CO detectors shall be installed in accordance to manufacturer specifications. All CO detectors must be hard-wired with battery back-up. CO detectors must be certified by CSA 6.19-01 or UL 2034.

Clarification

Combination smoke/CO detectors meet the intent provided they are certified by CSA 6.19-01 or UL 2034.

Confirmation

At final, Technical Advisor shall field verify that combustion detectors have been installed that are certified by CSA 6.19-01 or UL 2034.

IAQ 3: No unvented combustion appliances, fireplaces, or space heaters

Purpose

Due to indoor air safety, health, and moisture concerns, building scientists recommend that unvented appliances never be installed within the conditioned space of homes. Additionally, atmospherically vented and/or fan-assisted draft systems should be installed separate from the conditioned space.

Unvented systems are identified as having no systems to vent combustion by-products to the exterior. Atmospherically vented and fan-assisted appliances rely on surrounding atmosphere to provide for ventilation of combustion by-products to the exterior. Each type of appliance has the risk of introducing harmful combustion gases, such as carbon monoxide, and moisture vapor back into the space in which they are located - greatly adding to indoor humidity levels and increasing the risk of unsafe indoor environmental conditions for building occupants.

Criteria

Unvented combustion appliances, fireplaces or space heaters should not be installed within or adjacent to the conditioned space of the home. Atmospherically vented and fan-assisted draft appliances should be installed separate from the conditioned space.

Clarifications

Vent all combustion fireplaces and appliances to remove combustion products as well as process fumes to the exterior of a building.

Atmospherically vented and fan-assisted draft appliances may be installed in unconditioned locations adjacent to conditioned space, however all walls, floors and ceilings separating the appliances from conditioned space shall be air sealed and insulated to meet the IECC 2015.

Confirmation

- The technical advisor will visually confirm compliance during the mid-construction review and final inspection.
- Technical Advisors shall field verify that atmospherically vented and/or fan assisted draft appliances have been separated from conditioned space via a blower door test.

IAQ 4: If installed, fireplace has ducted outdoor air supply with damper

Purpose

If installed, all fireplaces should be installed with an air inlet designed to provide combustion air during operation to support adequate operation.

Criteria

All fireplaces must use a supply duct supplying outside air for combustion that complies with the fire code.

Combustion air inlet shall be equipped with a manual or mechanical damper that may be opened during operation of the fireplace and closed when the fireplace is not in use. Damper control shall be labeled for occupant use.

Confirmation

The EarthCraft technical advisor will visually confirm compliance during the mid-construction review and final field inspections.

IAQ 5: If in EPA Radon Zone 1, install a passive radon/soil gas vent system to exterior and label it clearly

Purpose

Radon is a naturally occurring radioactive gas that is present in the ground at varying concentrations across the country. It has been identified as one of the major causes of lung cancer, and homes susceptible to radon gases should be designed to prevent its entry into the home. This is accomplished through complete air sealing and venting of soil gases to separate the ground from the conditioned space.

Criteria

Required only if home is in Radon Zone 1, as defined by EPA Map of Radon Zones. The passive radon vent shall be installed to vent soil gases through the roof and shall be clearly marked as a Radon Vent.

Additional Resources

- EPA's map of radon zones, including state Radon Information and contacts can be found [here](#).
- EPA's "Building Radon Out" can be found online [here](#).

Confirmation

The EarthCraft technical advisor will visually confirm compliance during the mid-construction inspection.

Example

This is an example of a passive radon gas vent system.

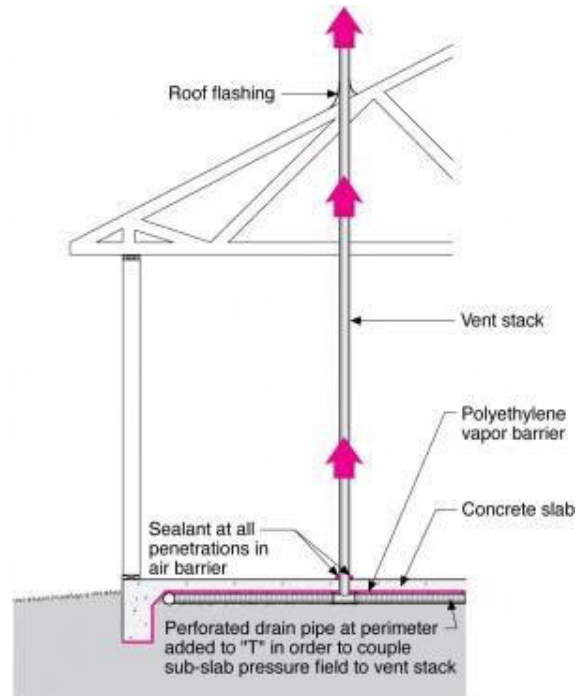

IAQ 6: Low- or no-formaldehyde content for finishes (choose minimum of three (3), details below):

- Subfloor/floor decking
- Insulation
- Interior trim
- Finished floor material
- All cabinets (kitchen, bathroom(s), laundry, etc.)
- All countertops (kitchen, bathroom(s), laundry, etc.)

Purpose

Formaldehyde is a colorless, flammable gas (at room temperature) which has a strong odor and is found in resins used in the manufacture of composite wood products and building materials. Exposure to formaldehyde may cause adverse health effects, primarily, irritation of skin, eyes, nose and throat. High levels of exposure may cause some types of cancers.

Criteria

Install composite wood products certified as compliant with formaldehyde emissions for at least one of the following:

- California Airborne Toxic Control Measure to Reduce Formaldehyde Emissions from Composite Wood Products Section 93120
- ANSI/HPVA HP-1-2009
- Kitchen Cabinet Manufacturers Association (KCMA) Environmental Stewardship Program (ESP) 05-12
- GREENGUARD or GREENGUARD GOLD

At least 90% of a product must meet this requirement to be accepted.

Confirmation

- The builder must present product documentation demonstrating compliance of product criteria to the EarthCraft Technical Advisor at the final inspection.
- The EarthCraft Technical Advisor will review documentation provided by the builder for compliance of criteria and visually confirm compliance of criteria at final inspection.

IAQ 7: Low- or no-VOC content paints, stains, or sealants (choose two (2), details below):

- Interior paints
- Interior stains
- Sealants (caulk, etc.)
- All carpet
- All carpet padding
- Carpet pad adhesive

Purpose

Interior paints and finishes may contain volatile organic compounds (VOCs) that can be harmful to humans, such as urea formaldehyde (UF), benzene, toluene, and other chemicals. VOCs from interior finish materials are released into the indoor air, creating unpleasant and sometimes toxic odors, with both short- and long-term health effects for workers and occupants. To protect indoor air quality for both occupants and contractor staff, the best approach is to limit use of VOC-containing materials by specifying and purchasing low- or no-VOC products. Paints, sealants, coatings and adhesives are building products that traditionally contain VOCs.

Criteria

Use only interior paints and finishes that are certified as low- or no-VOC by at least one of the following:

- CA Section 01350 (CDPH Standard Method V1.1-2010)
- Green Seal Standard GS-11
- Green Wise or Green Wise Gold
- GREENGUARD or GREENGUARD Gold Certification for Paints and Coatings
- Master Painters Institute (MPI) Green Performance Standards X-Green, GPS-1 or GPS-2
- Scientific Certification Systems (SCS) Standard EC-10.2-2007 or Indoor Advantage Gold

Use only sealants and adhesives that are certified as low- or no-VOC by at least one of the following:

- CA Section 01350 (CDPH Standard Method V1-1-2010)
- Green Seal GS-36
- GREENGUARD or GREENGUARD Gold adhesives and sealants

Use only carpet, carpet pad and carpet adhesives that are certified as low- or no-VOC by the Carpet and Rug Institute, Inc (CRI):

- CRI Green Label Plus for carpet and carpet adhesives
- CRI Green Label for carpet pad

In order to qualify, ≥90% of the interior surface covered by site-applied paints, coatings, sealants or carpet shall use low- or no-VOC products certified by one or more of the third-party standards listed above.

Additional Resources

- CA Section 01350: <http://www.calrecycle.ca.gov/greenbuilding/specs/section01350/>
- Carpet and Rug Institute, Inc: <http://www.carpet-rug.org/>
- Green Seal: <http://www.greenseal.org/>
- Green Wise Paint: <http://greenwisepaint.com/>
- GREENGUARD: <http://greenguard.org/en/index.aspx>
- Master Painters Institute: <http://www.paintinfo.com/index.asp>
- Scientific Certification Systems (SCS): <https://www.scsglobalservices.com/>

Confirmation

- The builder must present documentation demonstrating compliance of criteria to the EarthCraft Technical Advisor prior to submitting project for certification.
- The EarthCraft Technical Advisor will review documentation provided by the builder for compliance of criteria.

HLTH 1: Install whole building ventilation system designed to meet ASHRAE 62.2-2019 (choose one):

- **Energy recovery ventilator**
- **Whole house dehumidification ventilator**
- **Central fan integrated system with \geq MERV 8 filter for outdoor air prior to crossing HVAC heat exchanger/coils. HVAC system must be equipped with variable speed fan motor and thermostat control.**
- **Balanced system with monitoring controls for outdoor air humidity and/or temperature**
- **Supply system with monitoring controls for outdoor air humidity and/or temperature and \geq MERV 6 filter for outdoor air prior to entering conditioned space**

Purpose

Whole-house ventilation introduces fresh air into living spaces to dilute pollutants that cannot be removed completely through spot ventilation and/or filtration, thus providing for a healthy indoor environment. Advanced whole building ventilation systems account for outdoor air humidity through built-in air tempering, dehumidification and/or sensor controls.

Criteria

Install a whole building ventilation system designed to meet the air flow requirements of ASHRAE 62.2-2016. Refer to IAQ 1 for cfm sizing information. Projects seeking the Health badge shall install a system design meeting HLTH 1. All air flow cfm verification testing shall comply with ASHRAE 62.2-2016.

Confirmation

The HVAC Manual J Load Calculation shall include whole building ventilation cfm based on the calculations in ASHRAE 62.2-2016. The Technical Advisor will review the Manual J report to verify system has been designed for ventilation airflow. At final, Technical Advisor shall field verify that installed ventilation airflow cfm meets the minimum continuous airflow required.

Note:

- Projects may design whole building ventilation cfm using the infiltration credit in ASHRAE 62.2-2016. Technical Advisor shall review Manual J input for reasonableness, and at final shall field verify actual building envelope infiltration and ventilation airflow cfm. If necessary, whole building ventilation shall be field adjusted to comply with ASHRAE 62.2016.

- Projects using the Prescriptive Duct Sizing Table for local exhaust shall document compliance with photo documentation capturing $\geq 75\%$ of the distribution system

HLTH 2: All exhaust fans in full bathrooms designed and installed to activate by humidistat

Purpose

A humidistat helps monitor and maintain the set or preferred indoor relative humidity in the air without the need for occupant-initiated operation.

Criteria

Install a bath fan with indoor air humidity control (i.e., a humidistat) for all bathrooms with tubs and showers.

Provide information on type of system, maintenance, and monitoring requirements in project specific owner's manual.

Confirmation

The EarthCraft Technical Advisor will visually confirm compliance of criteria at final inspection.

Note: Local exhaust cfm shall meet ASHRAE 62.2-2016. Refer to IAQ 1 for sizing requirements.

HLTH 3: Sealed combustion, direct-vent fireplace(s) or no fireplace

Purpose

In order to ensure good indoor air quality, all combustion appliances are recommended to be sealed combustion units, as opposed to naturally aspirated units. These systems are completely decoupled from the interior environment through the use of dedicated outdoor air intake and exhaust ducts connected directly to the unit and gasket sealed doors. This design completely disconnects the combustion process from the interior environment and eliminates concerns of back drafting of the unit into conditioned space.

Criteria

All installed fireplaces must meet indoor air quality guidelines below and sealed combustion, direct ventilation with permanent, gasketed door.

OR

Do not install a fireplace.

Clarification

Fireplaces that meet these guidelines include:

- Gas or propane powered, sealed combustion and direct or power vented as rated by the American Gas Association (AGA) with a permanently affixed glass front.

Confirmation

The EarthCraft Technical Advisor will visually confirm compliance of criteria at final inspection.

HLTH 4: HVAC system designed for \geq MERV 13 pleated filter with minimum 2" filter slot

Purpose

To allow for greater surface area and lower resistance to airflow. Pleated air filters are more effective than other mechanical air filters because they contain more fiber per square inch than mechanical air filters.

Criteria

Design HVAC system for a \geq MERV 13 filtration (according to ASHRAE 52.2) on all HVAC systems. Filter slot must be designed to accommodate installed filter.

Clarification

HVAC design and installation must account for airflow based on filter selection.

Confirmation

The EarthCraft Technical Advisor will visually confirm compliance of criteria at mid-construction and final inspections.

HLTH 5: Follow the below garage ventilation guidelines (Details below):

- **Air leakage test to confirm complete air barrier between attached garage and living space**
- **Install exhaust fan vented to exterior with on/off control by motion sensor or timer**
- **Detached garage or no garage**

Purpose

Attached garages have the potential to allow carbon monoxide and other pollutants to enter the living space. As a good practice, mechanical ventilation should be provided in any attached garage to vent combustion products produced by vehicles.

Criteria

Attached garage: Install exhaust fan vented to exterior with on/off control by motion sensor or timer:

- Install an exhaust fan in an attached garage that operates continuously or operates whenever the garage is occupied and for at least 1 hour after the garage has been vacated.

Detached garage or no garage

- Isolate the garage by a minimum of 4' from the exterior walls or exterior floor of any conditioned area of the house OR
- Design and construct home with an open-carport or no garage

Clarifications

- If operating continuously, install an EnergyStar certified fan that is rated at a minimum of 75 cfm.
- If operating whenever the garage is occupied and for at least 1 hour after the garage has been vacated, install fan that is rated at a minimum of 100 cfm of airflow and is controlled by a timer or motion sensor.

Confirmation

The Technical Advisor will confirm compliance during the mid-construction inspection and verify compliance during the final inspection.

HLTH 6: Select a minimum of three (3) options from both IAQ 6 and IAQ 7

Purpose

Install products that are low/no-VOC and low/no-formaldehyde to protect future residents from known indoor environment contaminants.

Criteria

Select three (3) items from IAQ 6 and three items from IAQ 7 to meet the requirements of this credit.

Confirmation

- The builder must present documentation demonstrating compliance of criteria to the EarthCraft Technical Advisor prior to submitting project for certification.
- The EarthCraft Technical Advisor will review documentation provided by the builder for compliance of criteria.

Plumbing and Irrigation (PI)

Conserving finite freshwater resources has become vitally important in both protecting our environment and helping sustain economic growth in our region. The use of certain strategies like water-efficient fixtures, water-efficient landscaping and irrigation, and reusing water on-site through rainwater or gray water systems can significantly reduce a resident's water consumption as well as their utility bills.

The Plumbing and Irrigation section emphasizes the efficient use of potable water indoors and outdoors. An EarthCraft project aims to reduce water waste and storm water run-off. Strategies include drought adapted landscaping, improved plumbing distributions systems and efficient plumbing fixtures.

PI 1: High efficiency water heater (determined by Energy Factor; see chart below):

Purpose

With conventional gas storage water heaters less than 50% of the fuel energy input reaches the point of use. To reduce the amount of energy needed for water heating, the builder can install high-efficiency electric or gas water heaters. This results in reduced excess heating lost.

Criteria

Install a high efficiency storage water heater that meets the Energy Factor (EF) or Uniform Energy Factor (UEF) requirements in the following table for gas or electric operation:

Electric	Standard Storage, Medium Usage Bin	30 Gallon: ≥ 0.94 UEF 40 Gallon: ≥ 0.94 UEF 50 Gallon: ≥ 0.93 UEF 55 Gallon: ≥ 0.93 UEF
	Integrated Heat Pump	> 3.00 UEF
	Split System Heat Pump	> 2.00 UEF
Gas	≤ 55 Gallon Storage	Medium Usage Bin: ≥ 0.64 UEF High Usage Bin: ≥ 0.68 UEF
	> 55 Gallon Storage	Medium Usage Bin: ≥ 0.78 UEF High Usage Bin: ≥ 0.80 UEF
	Instantaneous	≥ 0.87 UEF
Solar	Electric Backup	≥ 3.00 Solar UEF
	Gas Backup	≥ 1.80 Solar UEF

Confirmation

- The builder must present documentation demonstrating compliance of criteria to the EarthCraft Technical Advisor prior to submitting project for certification.
- The EarthCraft Technical Advisor will review documentation provided by the builder and visually confirm compliance of criteria at final inspection.

Examples

Electric Storage Tank



High efficiency electric heat-pump storage water heater

Gas Storage Tank



If installed, a gas water heater must be direct vent, power vented or separated 100% from living space (pictured)

PI 2: Heat trap on all storage water heaters

Purpose

Heat traps increase overall efficiency for storage water heaters by preventing heat loss from inside the storage tank when flow stops.

Criteria

If installing a storage water heater, either purchase storage water heater with a heat trap preinstalled or install heat trap on storage water heater.

Clarifications

Appliances equipped with an internal heat trap may be verified through the unit specification sheet supplied by the manufacturer.

Confirmation

The EarthCraft Technical Advisor will visually confirm compliance of criteria at final inspection.

PI 3: Insulate 100% of hot water pipe with >R-3

Purpose

Installing insulation on hot water lines helps keep the water warm between uses, saving energy and conserving water. Insulation also helps eliminate condensation on cold water pipes and prevents them from freezing in areas such as unconditioned crawl spaces.

Criteria

Insulate all hot water pipes to R-3 or greater using polyethylene, neoprene, fiberglass or other insulation types. Fit insulation tightly around hot water pipe, face seam down and secure insulation every 2 feet using wire, tape or clamp. Install insulation on all piping elbows to adequately insulate 90-degree bend.

Exemptions

Hydronic heating systems are not required to insulate pipes in slabs or other approved materials intended for radiating heat into home and therefore do not apply to this criterion.

Confirmation

- The builder must present documentation demonstrating compliance of criteria to the EarthCraft Technical Advisor prior to submitting project for certification.
- The EarthCraft Technical Advisor will visually confirm compliance of criteria at mid-construction.

Examples



Insulate 100% of hot water pipe

PI 4: Water pressure \leq 60 PSI for fixtures

Purpose

Reduced water pressure saves water, conserves energy, and helps ensure proper operation of fixtures and appliances.

Criteria

Upon installation of the plumbing system, verify that the static service pressure is a maximum of 60 pounds per square inch (psi) (414 kilopascals [kPa]).

Clarifications

Units supplied by a municipal water supply must either use pressure regulating valve (PRV) upstream of all fixture connections or provide documentation from the public water supplier stating that water pressure will not exceed 60 psi.

Units supplied by groundwater wells must meet this requirement by installing a pressure tank.

Confirmation

The builder must present documentation demonstrating compliance of criteria to the EarthCraft Technical Advisor prior to submitting project for certification, or TA may verify water pressure during final inspection.

PI 5: WaterSense labeled toilets, showerheads, lavatory faucets and accessories (all must comply; details below):

- Toilets: ≤ 1.28 gpf
- Showerheads: ≤ 1.75 gpm. Exception: a shower with multiple showerheads must have a total combined flow rating of ≤ 3.0 gpm
- Lavatory faucets: ≤ 1.5 gpm
- Kitchen faucet: ≤ 1.5 gpm

Purpose

WaterSense is a U.S. Environmental Protection Agency program designed to encourage water efficiency through the use of a special label on consumer products. This label distinguishes the product as one that is beneficial for the environment through design that minimizes water use while meeting specific performance criteria. EPA criteria must be met in order for a product to receive a WaterSense label.

Criteria

WaterSense labeled toilets, showerheads, lavatory faucets and accessories (all must comply; Details below):

- Toilets: ≤ 1.28 gpf
- Showerheads: ≤ 1.75 gpm. Exception: a shower with multiple showerheads must have a total combined flow rating of ≤ 3.0 gpm
- Lavatory faucets: ≤ 1.5 gpm
- Kitchen faucet: ≤ 1.5 gpm

Additional Resources

A list of WaterSense labeled fixtures can be found [here](#).

Confirmation

- The builder must present documentation demonstrating compliance of criteria to the EarthCraft Technical Advisor prior to submitting project for certification.
- The EarthCraft Technical Advisor will review documentation provided by the builder for compliance

PI 6: Irrigation system (details below):

- **Must have a weather-based controller**
- **Does not water hard surfaces such as sidewalks and home foundation**

Purpose

Water saving irrigation methods, such as rain sensors and shut-off devices, distribute water much more efficiently to landscaping. This conserves water because these devices are able to adjust their watering to current weather conditions. Overspray should be avoided because the excess water that cannot be absorbed will empty into the streets and local waterways, potentially impacting water quality. Therefore, irrigation systems should be designed to avoid overspray onto impervious surfaces.

Criteria

- Design irrigation system with zones based on water needs in each planting area. Attention should be given to the sprinklers at the tops and bottoms of sloped areas to prevent runoff.
- Provide weather station or soil moisture sensor on irrigation system
- Equip irrigation systems with technology that inhibits or interrupts operation of the irrigation system during periods of rainfall or sufficient moisture (e.g., rain sensors, soil moisture sensors)

Confirmation

- The builder must present documentation demonstrating compliance of criteria to the EarthCraft Technical Advisor prior to submitting project for certification.
- The EarthCraft Technical Advisor will review documentation provided by the builder for compliance of criteria.

PI 7: All pools or spas must have an appropriate cover

Purpose

Covers over installed pools and spas serve to reduce heat loss and evapotranspiration.

Criteria

Any installed pools or spas must have an appropriate cover. Provide information on type of system, maintenance, and monitoring requirements in project-specific owner's manual.

Confirmation

The EarthCraft Technical Advisor will visually confirm compliance of criteria at final inspection.

Example

Correct



PI 8: Ornamental water features must recirculate water

Purpose

When ornamental water features are included in a project they should be designed to be as energy- and water-efficient as possible through recirculation.

Criteria

Install ornamental water feature that recirculates water from the feature itself and serve a beneficial use.

Provide information on type of system, maintenance, and monitoring requirements in project specific owner's manual.

Confirmation

The EarthCraft Technical Advisor will visually confirm compliance of criteria at final inspection.

PERF 4: Water heater efficiency meets or exceeds code requirement; gas water heaters must be separate from living space

Purpose

To allow for flexibility with energy modeling requirements outlined in PERF 1, projects are allowed to meet US Department of Energy requirements for building envelope insulation levels (R-value) where they differ from the requirements outlined in PL 1.

Criteria

Comply with current state appliance efficiency requirements for water heater UEF.

Clarification

- If gas heating equipment will be used it must be sealed combustion.

Confirmation

- The builder must present documentation demonstrating compliance of criteria to the EarthCraft Technical Advisor at mid-construction.
- The EarthCraft Technical Advisor will develop an energy model in accordance with RESNET modeling criteria and confirm compliance of criteria at mid-construction and final inspections.

PERF 5: Water Efficiency Rating Index <65

Purpose

A Water Efficiency Rating compares the anticipated water consumption of a home with industry standards for water fixture flow ratings and irrigation systems. Similarly to a HERS rating, a WER allows consumers the opportunity to compare the water efficiency score of their home to a neighboring home.

Criteria

Complete the WER Index section of the HERS model for the home. All required inputs must be provided.

Confirmation

The WER collects information on indoor and outdoor domestic water use, including all indoor plumbing fixtures, pools and irrigation systems. The following information will need to be provided:

- Indoor plumbing fixture flow rate specifications for kitchen, lavatory, showers and toilets
- If project has a hot water recirculation pump, provide specifications on standard system pipe length, loop and branch length and pump watts. Follow RESNET approved procedure for determining pipe lengths
- If project has a domestic water heat recovery, document specifications on showers and DWHR efficiency 2
- If project has an outdoor irrigation system, determine sum of all irrigation flow rates through one of the following:
 - Timed measurement in gallons per day
 - If house has a digital water meter, time flow rate with all taps open to determine gallons per day
 - A Residential Irrigation Capacity Index (RICI) may be applied to homes that document the total flow rate of all irrigation taps in relation the area of irrigated space. A RICI may adjust the portion of water use associated with irrigation (less the water use associated for pools) in the rated homes outdoor gpd by 10% for every point from a baseline RICI of 5: ○ INSERT RICI CALCULATION
- Document if project has an inground pool
- Determine if project uses a water softener

ENV 7: Irrigation (Details below):

- **Micro-irrigation system (e.g., drip irrigation) with pressure regulator, filter, and flush end assemblies**
- **Provide weather station or soil moisture sensor on irrigation system**

Purpose

Drip irrigation systems use 20% to 50% less water than conventional pop-up sprinkler systems and can save up to 30,000 gallons per year by delivering low volumes of water directly to plants' roots, minimizing losses to wind, runoff, evaporation, or overspray.

Weather-based irrigation controllers, which employ a "smart" irrigation control technology that uses local weather data to determine when and how much to water. These control technologies measure the moisture in the soil and tailor the irrigation schedule accordingly, rain sensors and rainfall shut-off devices that turn off irrigation on rainy days, and rotary spray sprinkler heads that lose less water to evaporation than misters.

Criteria

1. If installed, micro-irrigation system (a low-pressure irrigation system that sprays, mists, sprinkles or drips) includes a pressure regulator, filter and flush end assemblies. Micro irrigation shall be installed on separate zones from the rest of the irrigation system if sprinkler heads are used in other parts of the landscape.
2. Refer to credit WE6 for explanation on weather-based controllers

Confirmation

- The builder must present documentation demonstrating compliance of criteria to the EarthCraft Technical Advisor prior to submitting project for certification.
- The EarthCraft Technical Advisor will visually confirm compliance of criteria at final inspection.

RES 4: All faucets are single-lever or ADA compliant for all sinks, showers, and tubs.

Purpose

Provide fixtures that are designed to be easier, safer, and more comfortable to use for people with disabilities or limited mobility.

Criteria

Install plumbing fixtures that meet American with Disabilities Act (ADA) guidelines and ANSI A117.1. Fixtures must also meet PI 5 for flow-rating and WaterSense labeling requirements

Confirmation

- The builder must present documentation demonstrating compliance of criteria to the EarthCraft Technical Advisor prior to submitting project for certification.
- The EarthCraft Technical Advisor will visually confirm compliance of criteria at final inspection.

RES 5: Water leak detection equipment installed on water service line to house

Purpose

Provide a means to quickly detect plumbing leaks in order to protect the home structure from water damage and the homeowner from unexpected costs associated with water leaks.

Criteria

Install at least one water leak detection system that is integrated directly with the water supply line. System must have the ability to actively monitor for leaks, provide leak notifications, and automatically close the water supply line after a leak has been detected.

Confirmation

- The builder must present documentation demonstrating compliance of criteria to the EarthCraft Technical Advisor prior to submitting project for certification.
- The EarthCraft Technical Advisor will visually confirm compliance of criteria at mid-construction or final inspection.

Lighting and Appliances (LA)

Approximately 65 percent of U.S. electricity is generated by burning coal and natural gas, which releases greenhouse gases and other air pollutants into the atmosphere, contributing to climate change and air quality problems. Lighting and appliances use a significant amount of energy in buildings and selecting ENERGY STAR certified products, which use less energy than conventional models, and high-efficacy lighting can significantly lower residents' electricity consumption and their energy bills.

LA 1: High-efficacy lighting in 100% of all permanent indoor and outdoor fixtures

Purpose

Efficacy is the ratio of light produced to the amount of energy consumed. The higher the efficacy, the more light is produced for a given amount of energy - this results in reduced electric bill for homeowners and longer bulb lifespans.

Criteria

Install high-efficacy lighting in 100% of all permanent fixtures. High efficacy lighting includes compact fluorescent bulbs, LED bulbs, T-8 or smaller diameter linear fluorescent bulbs, or bulbs with a minimum efficacy of:

- 60 lumens per watt for bulbs over 40 watts
- 50 lumens per watt for bulbs from 15 watts to 40 watts
- 40 lumens per watt for bulbs 15 watts or less

Clarification

Any bulb that is ENERGY STAR rated will qualify

Additional Resources

Explanation of high-efficacy lighting can be found [here](#).

Confirmation

- The builder must present documentation demonstrating compliance of criteria to the EarthCraft Technical Advisor prior to submitting project for certification.
- The EarthCraft Technical Advisor will review documentation provided by the builder for compliance of criteria at final inspection.

LA 2: If installed, ENERGY STAR qualified dishwasher

Purpose

ENERGY STAR dishwashers must exceed the minimum federal efficiency standards for both energy and water use. A new ENERGY STAR certified dishwasher uses less than half as much energy as washing dishes by hand and saves nearly 5,000 gallons of water a year.

Criteria

All installed dishwashers must be ENERGY STAR qualified.

Clarification

As products and ENERGY STAR qualifications are periodically updated, the product must be labeled as an ENERGY STAR qualified product at the time it was purchased.

Additional Resources

A list of qualified products can be found [here](#).

Confirmation

- The builder must present documentation demonstrating compliance of criteria to the EarthCraft Technical Advisor prior to submitting project for certification.
- The EarthCraft Technical Advisor will review documentation provided by the builder for compliance of criteria and will visually confirm compliance of criteria at final inspection.

LA 3: If installed, ENERGY STAR qualified refrigerator

Purpose

ENERGY STAR refrigerators are about 9% more energy efficient on average than models that meet the federal minimum energy efficiency standard.

Criteria

All installed refrigerators must be ENERGY STAR qualified.

Clarification

As products and ENERGY STAR qualifications are periodically updated, the product must be labeled as an ENERGY STAR qualified product at the time it was purchased.

Additional Resources

A list of qualified products can be found [here](#).

Confirmation

- The builder must present documentation demonstrating compliance of criteria to the EarthCraft Technical Advisor prior to submitting project for certification.
- The EarthCraft Technical Advisor will review documentation provided by the builder for compliance of criteria and will visually confirm compliance of criteria at final inspection.

LA 4: If installed, ENERGY STAR qualified clothes washer (water factor ≤6.0 gal)

Purpose

ENERGY STAR certified clothes washers save on energy and water costs — they use about 40% less water and about 25% less energy than a regular washer.

Criteria

Select an ENERGY STAR-rated washer and compare efficiencies between units by using the Energy Guide label.

All installed clothes washers must be ENERGY STAR qualified with a water factor of less than or equal to 6.0 gallons.

Clarification

As products and ENERGY STAR qualifications are periodically updated, the product must be labeled as an ENERGY STAR qualified product at the time it was purchased.

Additional Resources

A list of qualified products can be found [here](#).

Confirmation

- The builder must present documentation demonstrating compliance of criteria to the EarthCraft Technical Advisor prior to submitting project for certification.
- The EarthCraft Technical Advisor will review documentation provided by the builder for compliance of criteria and will visually confirm compliance of criteria at final inspection.

Education and Operations (EO)

An EarthCraft house can provide a homeowner with increased occupant comfort and well-being, as well as energy savings from improved building performance, but without proper homeowner education these benefits may not be fully realized.

The Education and Operations section focuses on providing a homeowner with the necessary materials and manuals to properly operate their home's systems in order to maximize energy and water performance and promote occupant health. Additionally, homeowner education provides resources on specific EarthCraft strategies and features. This section helps to ensure that the EarthCraft program is marketed and represented accurately in the public realm.

EO 1: Provide homeowner with project-specific owner's manual

Purpose

The homeowner's manual is a resource available to homeowners that outlines the proper operation and maintenance for the various systems, equipment and EarthCraft features of their home.

Criteria

Manual must contain, at a minimum, the following:

- Instructions for proper HVAC system operation and maintenance
- Instructions for proper operating procedure for irrigation system
- Overview of general home maintenance activities and frequency
- A copy of the EarthCraft certificate

Clarification

Equipment manuals are acceptable but shall be supplemented with clear and specific instructions to the homeowner on when and how equipment shall be used.

Additional Resources

EarthCraft has a template available for download at www.earthcraft.org/earthcraftprofessionals/resources

Confirmation

- The builder must present documentation demonstrating compliance of criteria to the EarthCraft Technical Advisor prior to submitting project for certification.
- The EarthCraft Technical Advisor will review documentation provided by the builder for compliance of criteria.

EO 2: EarthCraft House Certified Builder

Purpose

To ensure that each house is completed by a builder that is familiar with the EarthCraft standards and expectations, builders must be certified by EarthCraft and satisfy all applicable credential requirements.

Criteria

The home must be constructed by an EarthCraft Certified Builder that is in good standing with program administrators.

Clarification

EarthCraft administrators will verify this requirement at registration. A project registration will not be processed if this requirement is not met.

Additional Resources

Information on how to become an EarthCraft builder and credential maintenance can be found at www.earthcraft.org/earthcraft-professionals/become-certified

Confirmation

Once project registration is submitted, EarthCraft administrators will confirm the builder associated to that project is certified and in good standing.

EO 3: Market EarthCraft House program

Purpose

Marketing the EarthCraft House program helps educate the local market and drive continued demand for high performance development.

Criteria

Include EarthCraft House logo in all print materials, websites, advertisements and other promotional materials associated with project promotion.

Post an EarthCraft House sign in the front yard of the home during construction.

Clarification

Technical Advisors will verify that proper on-site marketing (i.e. EarthCraft House sign) is installed in the front yard of the home during construction.

Additional Resources

Yard signs are sent to EarthCraft Builders following project registration.

The EarthCraft logo may be requested by reaching out to marketing@earthcraft.org.

All additional marketing resources can be found at www.earthcraft.org/earthcraftprofessionals/resources/marketing-logo-guidelines/

Confirmation

The EarthCraft Technical Advisor will verbally and visually confirm compliance of criteria with the builder at the pre-drywall and final inspections.