

Sustainable Preservation

Technical Guidelines

THIS PAGE LEFT INTENTIONALLY BLANK

Forward

The Sustainable Preservation Program was developed by Southface in partnership with the Georgia Trust for Historic Preservation in 2013 to provide guidance to projects seeking to renovate historic buildings sustainably. Expanding access to preservation best practices within the framework of green building and meeting the needs for a sustainability roadmap for historic buildings supports Southface's commitment to promoting sustainable homes, workplaces and communities and The Georgia Trust's mission to work for the preservation and revitalization of Georgia's diverse historic resources and advocate for their appreciation, protection and use.

The vision for this Sustainable Preservation program was developed in 2010 by The Georgia Trust's Sustainability Task Force. Created at the behest of Kim Taylor, Trust Board Chair, this volunteer committee of local architects, developers and allied nonprofits met initially at the March 2010 Greenprints Conference in Atlanta. The group's focus was to address obstacles and solutions to the promotion of environmental sustainability and resource efficiency in the preservation of historic buildings.

The Georgia Trust's Sustainability Task Force identified numerous energy saving characteristics that are inherent in historic buildings. These features include front and rear porches which shade doorways and windows, wide overhanging eaves which reduce heat gain, and operable windows that allow cross-ventilation in temperate seasons. It is also important in any construction project to minimize construction waste, as this debris accounts for 25% of the waste in our landfills each year. The rehabilitation of historic buildings greatly reduces this adverse impact.

Perhaps the most important positive benefit of rehabilitation is its role in retaining the embodied energy contained in the materials of buildings which are already constructed. This embodied energy represents the costs of energy inherent in durable building materials such as brick, concrete, wood, slate, plaster and other materials that have been previously extracted from the earth, transported to the building site and installed. To demolish historic buildings and haul these materials to a landfill is to throw away as well all the work that went in to the original construction and shows a lack of recognition of conservation principles.

Yet another advantage of rehabilitating existing buildings is their location. Historic buildings are predominantly located in the older and more centralized areas of our cities and communities and are therefore more likely to be adjacent to urban transit systems or are walkable to employment, shopping, entertainment and educational facilities. The energy savings represented by the conservation of these walkable neighborhoods is incalculable and often overlooked.

This Sustainable Preservation Program seeks to encourage the rehabilitation of historic buildings in order to take advantage of these assets and to transform our state and nation's building stock. Historic buildings which have energy-efficient design and systems can play a major role in the sustainable building movement.

The content presented in these guidelines is intended to assist projects in reaching their sustainability goals and evaluate the need for a green building program focused on the specific requirements of the renovation of historic buildings in a sustainable manner.

Disclaimer/Copyright Information

Southface and our partners authorize you to view the Sustainable Preservation Technical Guidelines for your individual project use and to copy as is, or in part as needed. However, no content in these Technical Guidelines may be altered. In exchange for this authorization, you agree to retain all copyright and other proprietary notices contained in the Technical Guidelines. You also agree not to sell or modify the Technical Guidelines.

Also note that none of the parties involved in the funding or creation of the Technical Guidelines, including the Georgia Trust for Historic Preservation, Southface or any of its associated Members, make any warranty (express or implied) or assume any liability or responsibility, to you or any third parties for the accuracy, completeness, or use of, or reliance on, any information contained in the Technical Guidelines, or for any injuries, losses or damages (including, without limitation, equitable relief) arising out of such use or reliance.

As a condition of use, you covenant not to sue, and agree to waive and release the Georgia Trust for Historic Preservation, Southface, demands and causes of action for any injuries, losses or damages (including, without limitation, equitable relief) that you may now or hereafter have a right to assert against such parties as a result of your use of, or reliance on, the Technical Guidelines.

Please note that the program participant is solely responsible for the project's design and construction. Southface and its representatives are responsible only for verification of the completion of Sustainable Preservation requirements and point items as set forth in the Technical Guidelines; such verification in no way constitutes a warranty as to the sufficiency, quality, preparation or comprehensiveness of the final design or for the construction of the Project in accordance with the approved final design. Southface and its representatives shall not have control over, nor be responsible for, the construction means or methods, construction techniques, construction sequencing, or for safety precautions required of the ECSP Project.

Acknowledgements

Southface would like to thank those who have provided invaluable assistance and support during the development of the Sustainable Preservation Program and Technical Guidelines.

Sustainable Preservation Program Development Advisors

Stacie Monroe
Jesse Erbel
Pratt Cassity
Susan Kidd
Mark McDonald

re:FORM Architects
The Sustainability Institute
University of Georgia
Agnes Scott College
Georgia Trust for Historic Preservation

Financial/Technical Supporters

Georgia Trust for Historic Preservation

In addition, Southface appreciates its staff and program partners for their continued commitment to environmentally responsible design and construction across the Southeast.

Introduction

ABOUT SOUTHFACE

Since 1978, Southface has worked with consumers, the construction and development industry and policymakers to forge market-based solutions for creating green jobs, clean energy solutions and sustainable communities. Recognizing that buildings produce nearly half of all U.S. greenhouse gas emissions, we believe that sustainability initiatives and advocacy focused on the built environment are key to addressing global climate change.

Southface is also strongly committed to helping people live, work and play in comfortable, healthy buildings that save money by conserving energy, water and other natural resources.

To accomplish these goals, Southface offers a wide variety of green building and sustainability programs and services, all of which are based on sound science.

ABOUT THE GEORGIA TRUST FOR HISTORIC PRESERVATION

The Mission of the Georgia Trust for Historic Preservation is to work for the preservation and revitalization of Georgia's diverse historic resources and advocate their appreciation, protection and use.

The Vision of the Georgia Trust for Historic Preservation is for Georgians to understand and appreciate the irreplaceable value of historic buildings and places and their relevance to modern life. We envision Georgians who promote careful stewardship and active use of these diverse resources and recognize the economic and cultural benefits of preservation. We envision communities where new development complements and reinforces thriving downtowns and historic neighborhoods, contributing to a healthy and enriched humane environment.

ABOUT THE SUSTAINABLE PRESERVATION PROGRAM

The Sustainable Preservation Program is built upon the principles of historic preservation and building science. It was developed to encourage sustainable design and rehabilitation of historic buildings. As with other Southface programs, the Sustainable Preservation Program is regionally specific, and created to promote energy efficiency, water efficiency, resource efficiency, durable construction and healthier environments for building occupants.

The Program is available for historic renovation and restoration projects 15,000 square feet or less and located in climate zones 2a, 3a or 4a. Projects over 15,000 and up to 25,000 square feet are accepted into the program on a case-by-case basis.

Program Benefits

- Third-party certification of environmentally responsible design and construction
- Technical guidance during planning, design and construction
- Project administration from registration until final certification ▪ Expedited certification process

through field-verified documentation ▪ Better overall building performance, including:

- ✓ An integrated systems approach
- ✓ Efficient use of natural resources: water, energy and building materials
- ✓ Tighter building envelope and ductwork
- ✓ Improved indoor air quality and a comfortable working environment
- ✓ Potential cost savings due to reduction in utilities demand for water and energy

Contact Information

Southface Website _____ www.southface.org

Southface Main Line _____ 404.872.3549

Southface Mailing Address _____ 241 Pine Street, NE, Atlanta, GA 30308

Georgia Trust Website _____ www.georgiatrust.org

Georgia Trust Main Line _____ 404.881.9980

Georgia Trust Mailing Address _____ 1516 Peachtree Street, NW, Atlanta, GA 30309

PROJECT ELIGIBILITY

Eligible Projects must meet the following characteristics:

- Historic Renovation or Restoration Projects
- Projects implementing standard preservation best practices (The Secretary of the Interior's Standards, local preservation ordinances, State Historic Preservation Office recommendations)
- Project site is located in Southeastern U.S. Climate Zones 2a, 3a or 4a according to the Department of Energy's Climate Zone Map (below)

*The Sustainable Preservation Program is not intended to be used in lieu of existing historic preservation programs, but is intended to supplement preservation best practices and recognize the environmental attributes of historic buildings, while assisting historic preservation projects in meeting their environmental goals.

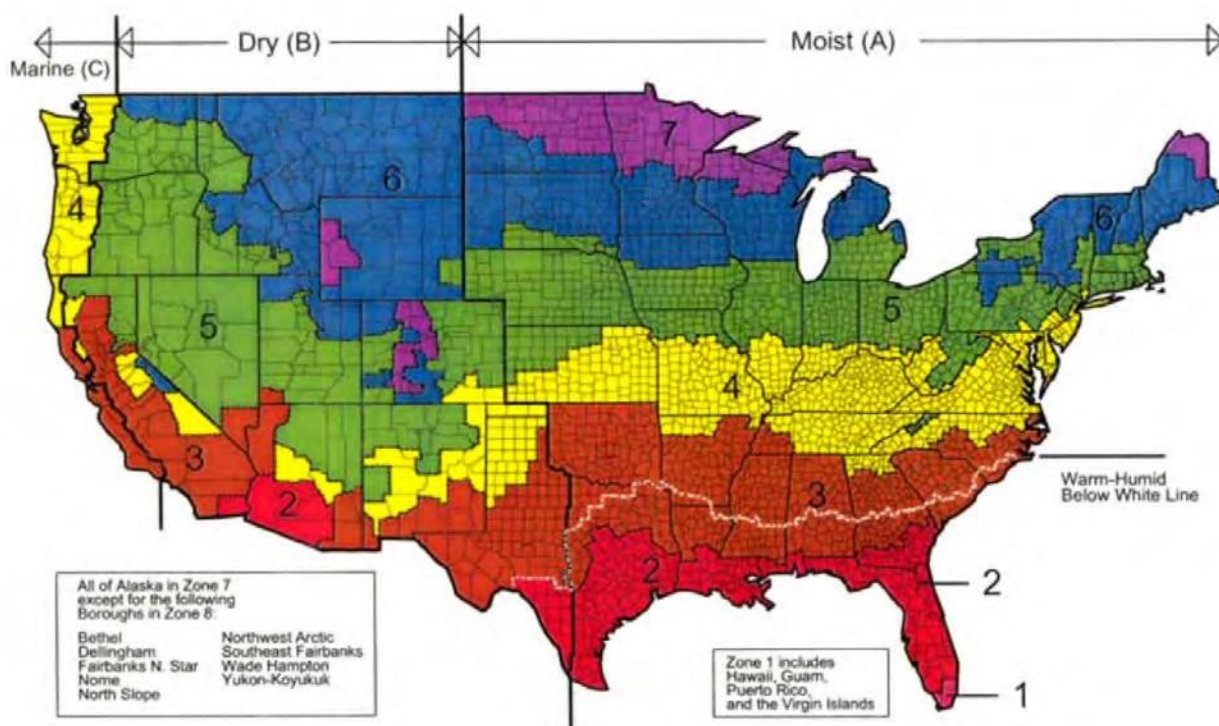

Examples of projects not eligible to seek ECLC Certification are:

- Projects that cannot meet ALL of the criteria listed above
- Projects that are not following standard preservation best practices

SUSTAINABLE PRESERVATION WORKSHEET AND TECHNICAL GUIDELINES OVERVIEW

The Sustainable Preservation Technical Guidelines are meant to be used in conjunction with the Worksheet. Each item on the worksheet is explained in more detail in the Technical Guidelines. Before beginning any project, the project team should contact a Southface Projects Manager to ensure they are referencing the most current versions of the Worksheet and Technical Guidelines. Technical Guidelines and Worksheet version numbers are indicated in the lower left corner of the documents.

It is important to note that when local building and/or energy codes are more stringent than the Sustainable Preservation Technical Guidelines, the local code(s) must be followed. The project team should notify the Project Manager of any program conflicts with local building code(s).

Sustainable Preservation Worksheet

The Sustainable Preservation Worksheet is a tool intended to track a projects progress towards Program certification. The worksheet is an Excel file available for download, and it contains the following information:

- Project Summary
- Program Worksheet (inclusive of Requirements and Point Items)
- Building Flush-out Calculator

Sustainable Preservation Technical Guidelines

The Sustainable Preservation Technical Guidelines discuss each Sustainable Preservation Requirement and Point Item in detail, including the **Purpose**, **Criteria** and **Verification**.

- Purpose - Explains the reason a Requirement or Point Item is in the program.
- Criteria - A detailed description of what a project must do to meet a Requirement or Point Item.
- Verification - Information on how each Requirement and Point Item will be verified. Many Requirements and Point Items can be visually verified through on-site inspections; however there are some that require other forms of documentation.

New Construction Requirements Section

The New Construction Requirements Sections of the Worksheet and Technical Guidelines is only applicable to additions to historic buildings greater than 500 square feet but not more than 2% of total original project building area.

Based on high performance building best practices and the standards of the Earthcraft Light Commercial Program, these requirements are intended to guide project teams when creating new additions as part of the renovation of a historic structure.

Project team should always consult with preservation professionals, local guidelines, and preservation best practices when considering additions to historic buildings in order to ensure appropriate design.

PROGRAM RESOURCES

EarthCraft Website www.earthcraft.org

American Society of Heating, Refrigerating and Air-Conditioning Engineers (ASHRAE)

ASHRAE Standard 90.1-2007

ASHRAE Standard 90.1-2007 User's Manual

ASHRAE Standard 62.1-2007 www.ashrae.org

U.S. Department of Energy | Energy Efficiency & Renewable Energy

Building Energy Codes Program

COMcheck software www.energycodes.gov

National Park Service

Secretary of the Interior's Standards for Rehabilitating Historic Buildings

Technical Preservation Services www.nps.gov

CERTIFICATION**Certification Process****SUSTAINABLE PRESERVATION CERTIFICATION OVERVIEW**

Each project seeking certification must begin with registration. Upon registration, the project contact will receive a formal registration confirmation and agreement form to sign and return to initiate the certification process. Any project deemed ineligible at the time of registration will have all registration fees fully refunded, along with a brief explanation of the reason for ineligibility.

Once the registration process is complete, the project contact will be assigned a Project Manager who will then schedule the initial Site Assessment. From this point, all communications, including those to schedule meetings and site visits, will be with the project's assigned Project Manager.

An important part of the certification process is documentation through field verification and performance testing. All project participants are subject to site visits and minimum air tightness requirements. This part of the program ensures expedited certification, as well as field-verified measures of performance upon construction completion.

Three levels of certification are available to program participants, assigned based on meeting all Requirements and the number of points achieved: Certified = 100 points, Gold = 150 points, Platinum = 200 points.

Certification Process Milestones

There are eight key milestones as a project moves through the certification process. Each step in the process is described in more detail on the following pages.

PLANNING & DESIGN**CONSTRUCTION****CERTIFICATION**

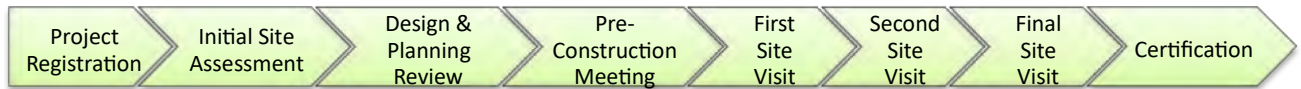

1. Project Registration and Contractual Agreement
2. Initial Site Assessment
3. Design and Planning Review
4. Pre-construction Meeting
5. First Site Visit
6. Second Site Visit
7. Final Inspection and Testing
8. Certification Application

PROJECT REGISTRATION

The project team should register the project as early in the design phase as possible. There is a fee of \$100 for project registration to cover costs associated with project processing and preliminary review.

Upon receipt of registration and payment, a Sustainable Preservation Agreement Form will be generated for the owner or owner's representative to sign. Once the signed document is received, a confirmation email will be sent to the project team and a Project Manager will be assigned to guide the project through completion. The Project Manager will then contact the primary project contact to schedule an initial Design and Planning Review.

To register a Project, contact Southface.

Note: Registration does not guarantee certification. Certification is dependent on the successful fulfillment of all program requirements, including air leakage testing, as well as achieving a minimum of 100 points.

INITIAL SITE ASSESSMENT

Once the project team has successfully registered with the Program and the Agreement Form has been signed and submitted, a Project Manager will be assigned to guide the team through the certification process. The first step will be to schedule an initial site assessment.

One purpose of the initial site assessment is to determine the condition of the historic building's existing inherently-sustainable features, such as shutters, storm windows, awnings, porches, natural ventilation, roof monitors, skylights, light wells, transoms and naturally-lit corridors. Identifying these features and their condition early in the project allows them to be included in the planning stages before considering retrofit upgrades. Retaining and restoring these features benefits the project from both a sustainability and preservation perspective. Any other significant historic features unique to the project, which may not contribute to the energy efficiency of the building but should be maintained due to preservation best practices, will also be identified in this stage.

The initial site assessment also allows for the use of a variety of diagnostic tools, such as an energy assessment, blower door tests, infrared thermography, and energy modeling to gain an understanding of the building's performance and potential before renovation. These tests help establish an envelope leakage baseline for the structure and help identify opportunities to eliminate air infiltration, beginning with the least invasive and most cost-effective weatherization measures, such as caulking and weather stripping, before undertaking more invasive envelope upgrades. It is especially important to evaluate the thermal properties of the historic building materials and the insulating needs for the specific

climate zone and building type before attempting insulation upgrades which are likely to damage historic building materials.

Existing heating, ventilation, and air conditioning systems will also be assessed during the initial site assessment in order to identify opportunities to upgrade them to increase efficiency and performance without damage to historic building materials. Improving these systems with less invasive measures, such as programmable thermostats, ceiling fans, and operable windows, is preferable in most situations.

The Project Manager will provide a site assessment report highlighting the findings of the site assessment and detailing specific preservation and sustainability opportunities for the project.

CERTIFICATION

DESIGN AND PLANNING REVIEW

Once the project has had its initial site assessment, the Project Manager will schedule a Design and Planning Review with key members of the project's design team, including the project architect, mechanical engineer/contractor, and owner's representative. If the general contractor (GC) for the project has been identified at this stage in the process, it is highly recommended that they attend this meeting as well.

Submit the following information to the Project Manager prior to Design and Planning Review:

- Contact Information for Meeting Participants
- Current Project Plans and Specifications (in PDF format)
- Preliminary Worksheet (first pass at project point totals)
- Anticipated Construction Schedule

The Design and Planning Review is a "working" meeting, where the project team meets with representatives from Southface to participate in a 3-4 hour review of the project's plans. The Design Review is an opportunity to look carefully at the plans and determine how the program can be applied to

the project. From this exercise, the team can ensure that all requirements can be met, and a tentative point total on the Worksheet can be determined. To gain the most benefit from this meeting, it is recommended that this step in the process be implemented as early in the design process as possible.

PRE-CONSTRUCTION MEETING

Prior to construction, the GC (or primary project contact) must contact the Project Manager to schedule a Pre-Construction Meeting. The project's Construction Manager and Site Superintendent are expected to be present for the meeting. HVAC and insulation subcontractors are encouraged to attend if available.

Submit the following to the Project Manager Prior to Pre-Construction Meeting:

- Contact Information for Meeting Participants
- Updated Worksheet
- Final Construction Documents (PDF and hard copy to scale – preferably half size), including:
 - Site Plan (including Erosion & Sedimentation Control measures)
 - Landscape Plan
 - Lighting Schedule
 - Plumbing Schedule
 - HVAC Schedule
 - Duct Design Documentation
- Energy Code Compliance Documentation - *COMcheck*
- HVAC Load Calculations

The intent for this meeting is to review the project goals and the certification process before construction gets underway. The Project Manager will review the core requirements of the program, required site visits, performance tests and methods of collecting information needed to document worksheet items. The updated Worksheet will also be reviewed to insure the project is still on target to meet the goals set during the Design and Planning Review.

ALL program participants are required to pass maximum air leakage requirements for the building envelope, and any project with ductwork located outside the "thermal" envelope is also subject to meeting maximum duct leakage requirements in addition to the envelope testing.

FIRST SITE VISIT - INITIAL PROJECT WALKTHROUGH AND AIR SEALING INSPECTION

Each building to be certified through the Sustainable Preservation Program must go through the First Site Visit during construction to verify the retention of historic features, air sealing measures and renovation activities. The GC must contact the Project Manager to schedule this First Site Visit. The Construction Manager and Site Superintendent must be present during this visit.

Submit the following to Project Manager Prior to First Site Visit:

- Finalized Worksheet
- Updated Construction Schedule
- Construction Waste Management Plan
- HVAC and Plumbing Submittals

During this visit, the Project Manager will review project site strategies, building thermal envelope air sealing measures, applicable drainage plane and insulation applications and duct sealing measures. All relevant worksheet Requirements and Point Items that can be visually verified will also be documented.

Once this site visit is complete, the project team will receive a follow-up report with photographs of items that need attention, as well as recommendations for improving building performance. Additional photo documentation may be requested from the GC in order to demonstrate that the program criteria have been met. All requested photos must be submitted to the Project Manager prior to the Second Site Visit.

SECOND SITE VISIT

Each building to be certified through the program must undergo a Second Site Visit. The GC must contact the Project Manager to schedule this site visit. The Construction Manager and Site Superintendent must be present during this visit.

Submit the following to Project Manager prior to Second Site Visit:

- Photographs of all items required from First Site Visit Report
- Updated Construction Schedule
- Photographs of construction details that cannot be visually inspected during this site visit

The Second Site Visit is an on-site evaluation of the building thermal envelope as it relates to the program Requirements and Point Items, including insulation and additional air sealing opportunities to increase the success of final performance testing. The Project Manager will also inspect any installed ductwork and mechanical systems for appropriate sealing and insulation measures.

All other relevant worksheet Point Items that can be viewed at this time will also be documented. Once this site visit is complete, the project team will receive a follow-up report with photographs of items that need attention. Additional photo documentation may be requested from the GC in order to demonstrate that program criteria have been met. All requested photos must be submitted to the Project Manager prior to the Final Site Visit.

FINAL SITE VISIT

Each building to be certified through the program must participate in a Final Site Visit. Once construction is at a stage of substantial completion and all measures indicated on the Project Worksheet have been completed, the GC shall notify the Project Manager that the team is ready to schedule the Final Site Visit. The Construction Manager and Site Superintendent must be present during this visit.

Submit the following to Project Manager prior to Final Site Visit:

- ALL photographs requested from the Second Site Visit Report
- Paper documentation for Worksheet items that cannot be documented visually upon this visit

During this visit, all required leakage tests will be performed and the team will participate in a final walkthrough of the building and project site. All relevant worksheet items that can be verified on this visit will be noted; however some documentation for other worksheet items may still be needed in order to confirm all project goals have been met before certification can be awarded.

The project team will receive a Final Report with any remaining items that need to be resolved, as well as the air leakage test results. A final worksheet with notes regarding any missing documentation will be provided to the team for final documentation gathering.

Note: All required air leakage tests will be performed during this visit. At a minimum, the Project Manager will perform an Envelope Air Tightness Test to evaluate the building envelope for leakage, as well as Duct Leakage Testing (if required). For more information, refer to section BE R2: Envelope Air Tightness Performance Test and ES R4: Existing Duct System Leakage Test or ES R6: New Duct System Leakage Test in the Technical Guidelines.

If a project fails to pass required air leakage tests, the program participant will have the option of correcting the areas of concern and requesting additional tests be performed at a later date. There are additional fees associated with any supplementary performance testing. Please consult with the Project Manager for more information regarding additional costs and scheduling.

CERTIFICATION APPLICATION

The team can apply for certification once the following conditions have been met:

- All site visits have been completed
- All photo and paper documentation materials have been submitted
- All Requirements and a minimum of 100 points have successfully been verified
- The building has successfully passed all required performance tests

The Project Manager will supply the project team with a Certification Application Form, which will state the certification level and points achieved.

Upon receipt of the Certification Application Form, the team will be awarded an Sustainable Preservation plaque to display on the building. There are no additional costs for the plaque; however the project team should plan to allow 4-5 weeks for the plaque to arrive.

VARIANCE PROCEDURE

In the event that an extenuating circumstance (such as physical parameters or other insurmountable conditions) prohibits a project from its ability to achieve a specific program requirement, it is possible that a request for variance may be granted.

Variance RequestWho may Request the Variance:

The variance can be submitted by any member of the project team, but must be approved and signed by the owner or owner's representative before sending to the Project Manager.

When to Request the Variance:

The Variance Request should be submitted to the Project Manager as soon as the project team becomes aware of the extenuating circumstance.

Variance Request Format:

A signed affidavit identifying the requirement of consideration, describing the circumstance surrounding the project's inability to meet the criteria outlined in the Technical Guidelines, and a proposed alternative to meet the intent or "purpose" of that requirement.

Variance Approval

Variance requests are approved by the Sustainable Preservation Technical Review Team on a case-by-case basis. The approval of the request is largely based on the project's ability to meet the intent of the requirement. If a request is not granted, the participant must meet the criteria of the requirement outlined in the Technical Guidelines in order to achieve certification.

Variance Requests are not publicized and Southface will maintain anonymity of both the project and the Sustainable Preservation Technical Review Team members involved in the Variance Process.

Site Planning and Development

SP R1: Erosion and Sedimentation Control Plan – Best Practices

Purpose

Reduce water pollution from land disturbing activities.

Criteria

Create an Erosion and Sedimentation Control Plan (E&SC Plan) consistent with state or local best practices. The erosion control measures and plan should be provided to the Project Manager, maintained by the on-site contractor and adjusted as necessary throughout all construction phases.

Projects that are not required by local jurisdictions to provide an E&SC Plan that is stamped by an engineer should, at minimum, include the following measures/information for Erosion and Sediment Control Best Practices on the Project's Site Plan:

- Location of major roadways, streams and other bodies of water within 50 feet of the Project Boundary
- Major on-site topographic features, streams, existing soil types and vegetation located within the Project Boundary, as well as existing and proposed topographic contours greater than 2 feet
- Location and extent of erosion and sediment control measures, including both vegetative and structural practices, such as:
 - Perimeter silt fencing - installed and maintained properly to control runoff and siltation
 - Storm sewer inlets - protected with straw bales, compost socks, silt stacks or comparable measure
 - Erosion control blanket - used on steep slopes (greater than or equal to 15% change in elevation – a 1.5 foot rise over a 10-foot horizontal run constitutes a 15% slope)
 - Stabilization for all disturbed areas - stabilize with temporary seeding, straw, wood mulch or permanent vegetation immediately after rough grading is completed if a delay in finished grade is expected
 - Construction exit - to prevent construction debris from being tracked from vehicles onto public rights-of-way or into storm drains: at minimum, provide a stone-stabilized pad (minimum thickness of 6" and at least 20' x 20' in size) located at any point where traffic will be leaving the site to a public right-of-way, street, sidewalk, parking area
 - Name(s) and phone number(s) for personnel responsible for Erosion and Sedimentation Control on site

Resources

EPA's National Pollutant Discharge Elimination System (NPDES) Website www.epa.gov

Georgia Erosion and Sedimentation Control Manual www.gaepd.org

Virginia Erosion and Sediment Control Handbook www.dcr.virginia.gov

Verification

- Construction Documents include Erosion and Sedimentation Control Plan
- Verification by Project Manager

SP R2: Provide Phase I Environmental Test Report**Purpose**

Examine the site for potential contamination sources prior to construction.

Criteria

If a Phase I Environmental Site Assessment (ESA) is required by local or state authorities, provide a copy of the report to the Project Manager prior to construction.

A Phase I ESA will identify existing or potential or environmental contamination, and is typically followed by a Phase II ESA if evidence of contamination exists. A Phase II ESA will detail the contaminant of concern and the rehabilitation efforts required to remediate the site from the hazard identified.

*Not required for single family renovations.

Resources

U.S. Environmental Protection Agency Brownfield and Land Revitalization www.epa.gov

Verification

- Provide Phase I ESA Report prior to construction

SP R3: Provide Landscape Preservation, Rehabilitation & Restoration Plan**Purpose**

Communicate preservation, rehabilitation and restoration goals, as well as permanent landscape/hardscape features to be retained.

Criteria

Provide plan(s) of existing and/or permanent landscape measures.

The landscape plan should include the following as applicable:

- Greenspace and tree preservation measures
- Vegetation and hardscape areas
- Any information related to attempted point items, such as:
 - Permeable materials for hardscape areas
 - Shading for hardscape areas
 - Greenspace restoration measures
 - Specimen tree preservation
 - Tree planting: quantity, species, and caliper measurement
 - Permanently installed stormwater control measures
 - Efficient irrigation strategies

Verification

- Provide Landscape Plan to Project Manager prior to first site visit

SP R4: Label All Storm Drains and Storm Inlets**Purpose**

Discourage dumping of pollutants into drains connected to streams and rivers within the watershed.

Criteria

If stormwater inlets are within the Project Boundary, then all drains must be labeled to indicate its connection to streams and rivers within the watershed. Label can be in the form of an affixed medallion, or a clearly legible stencil application.

Label examples:

"No Dumping - Drains to Stream"

"No Dumping - Drains to Water Source"

"Rainwater Only"



Label Courtesy of DeKalb County Public Works

Resources

U.S. Environmental Protection Agency Storm Drain Marking www.epa.gov

Verification

- Verification by Project Manager

SP R5: Historic Tree Preservation

Purpose

Preserve and protect historic trees for future generations.

Criteria

Preserve all historic trees within the project boundary, and provide signage describing each tree's species, age and unique regional significance and/or other relevant attributes.

State or Local "Landmark and Historic Tree Program"

Preserve and register each culturally significant tree in a state or local "Landmark and Historic Tree Program."

The root zones of the historic tree(s) must be protected with a physical barrier during all site clearing, grading and construction activities. Tree(s) must be fenced around the drip line throughout the construction process with tall, bright, protective fencing. Avoid soil being placed on top of any root zone for trees that are designated for preservation. Ensure the protected tree species' needs for growth, sunlight and water integrate well with the new building design.

Resources

American Forests

www.americanforests.org

Georgia Urban Forestry Council www.gufc.org

Verification

- Landscape Plan indicates location, size and species of historic tree(s)
- Supporting documentation from a relevant tree preservation organization that indicates program participation
- Verification by Project Manager

SP 1: Building is Located within a Preservation District**5 points**

Purpose

Support and recognition for building renovation projects located within a Historic Preservation District.

Criteria

Project is located within the boundary of an existing Historic Preservation District or is located within the boundary of a district that is actively pursuing recognition through a local, state or national preservation entity.

A historic district is a group of buildings, properties, or sites that have been designated by one of several entities on different levels as historically or architecturally significant. Buildings and sites within a historic district are normally divided into two categories, contributing and non-contributing.

This point item is applicable to the renovation of either contributing or non-contributing buildings located within historic districts.

Qualifying Preservation Districts include:

Main Street District

A Main Street District is a community-based development initiative that encourages public and private partnerships to create successful central business districts. Main Street communities utilize local business owners, property owners, citizens, non-profit organizations, and local governments to build a comprehensive approach to sustainable downtown development.

Georgia Better Hometown District

DCA introduced the Better Hometown program as a way to apply the Main Street four point Approach™ to communities with populations under 5,000.

Local Historic Preservation District

Local historic preservation districts are areas where historic buildings are protected by public review, and contributing buildings are deemed significant to a city's cultural fabric. A property included in a local historic district has been identified as worthy of protection because it has qualities contributing to the unique history of the city.

National Historic Preservation District

Federally designated historic districts are listed on the National Register of Historic Places.

Resources

Georgia Main Street Program Webpage www.boomtowngeorgia.org

National Trust for Historic Preservation Webpage
www.preservationnation.org

National Park Service Webpage <http://www.nps.gov/nr/>

Verification

- Provide documentation of existing or planned Historic Preservation District to Project Manager

SP 2: Remediated Brownfield Site

2 points**Purpose**

Encourage mitigation and redevelopment of environmentally contaminated sites.

Criteria

The project is located on a site where any portion is identified as a Brownfield by the appropriate local, state or federal agency - OR - on a site documented as contaminated by a Phase II Environmental Site Assessment.

-AND-

Site has been remediated of documented contaminant.

Examples of projects that may qualify are those on or near abandoned gas stations, landfills, factories, industrial sites, junkyards, and other similar land use that could contain the following:

- Petroleum hydrocarbons (sources are often from underground storage tanks)
- Arsenic
- Pesticides and other hazardous chemicals
- Heavy metals such as lead, aluminum, iron and magnesium
- Asbestos

Resources

U.S. Environmental Protection Agency Brownfield and Land Revitalization www.epa.gov

Verification

- Phase II Environmental Site Assessment summary
- Narrative of remediation/mitigation measures

SP 3: Density, Walkability & Alternative Transportation**15 points**

Purpose

Encourage revitalization of historic properties in a dense urban setting, thereby improving the surrounding community and reducing the need for additional infrastructure.

Criteria

Project must achieve a minimum of five of the following seven items.

*Single family renovations must achieve four.

1. Previously Developed Site

Project is located on a previously developed site that is served by existing public sewer infrastructure.

Project site plan should include a narrative describing the existing site location, existing infrastructure, and adjacent property information.

2. Proximity to Mass Transit

Transit option must be located within the distance specified below and be publicly accessible by pedestrian commute.

Select one or both of the options below:

A. Within ¼ Mile of Public Bus Route

Project is located within ¼ mile walking distance of an existing or planned public bus route.

B. Within ½ Mile of Rail Station

Project is located within ½ mile walking distance of an existing or planned rail station.

Projects seeking points for planned public bus routes and/or rail stations must provide documentation stating that the amenity is both planned and funded.

3. Proximity to Bike Path

The building is located within ½ mile riding distance of an existing, or planned and funded, bike path.

4. Pedestrian Access

Create connectivity between the project site and the surrounding business and/or residential community by providing sidewalks at least 4 feet wide for all internal streets that connect with public access. Provide curb cuts and accessible routes, as defined by Americans with Disabilities Act (ADA) accessibility standards, for all new pedestrian routes.

5. Reduced Parking

Reduce the amount of parking below local zoning ordinance requirements and/or provide no new parking on site.

Select one or both of the options below:

A. No New Parking Provided**B. Reduced Parking Capacity**

Parking capacity must be at least 10% below local zoning ordinance.

6. Alternative Transportation Accommodations

Provide alternative transportation accommodations and include type(s) and location(s) on Site Plan.

Select two or more of the options below:

A. Bicycle Rack Accommodations

Provide bike rack near the main entryway.

B. Preferred Parking for Carpools

Provide parking that is in addition and equivalent to at least 50% of that required for ADA (handicapped) parking spaces. Parking spaces should be striped or signed for carpool use only and located secondary to the ADA spaces near main entryways.

C. Preferred Parking for Hybrid and/or Alternative Fuel Vehicles

Provide parking that is in addition and equivalent to at least 50% of that required for ADA (handicapped) parking spaces. Parking spaces should be striped or signed for hybrid/alternative fuel vehicle (AFV) use only and located secondary to the ADA spaces near main entryways.

D. Covered Bus Stop

Provide shelter for passengers for any public bus stop that is within the Project Boundary.

E. Alternative Vehicle Charging/Fueling Station

Provide a biodiesel, electric, ethanol, hydrogen, natural gas or propane vehicle charging/fueling station.

F. Vehicle Sharing Program

Provide a minimum of one parking space for vehicle sharing program, such as Zipcar.

7. Proximity to Destinations

Project is located within ½ mile of five of the following:

- School • Community Center
- Bank • Retail Establishment
- Public Park • Residential Area
- Restaurant • Office or Industrial
- Church Park
- Coffee House

Resources

U.S. Department of Energy, Alternative and Advanced Fuels www.afdc.energy.gov

Verification

- Construction Documents detail existing infrastructure and adjacent property type information
- Construction Documents clearly indicate locations of existing or planned bus route and/or rail station and walking distance from site
- For planned public bus route or rail line, provide plans and other documentation from the appropriate agency or organization verifying the layout and funding for the future amenity
- Construction Documents detail pedestrian accessibility
- Construction Documents clearly indicate number of parking spaces provided

- For projects attempting "Reduced Parking Capacity," provide affidavit indicating number of required parking per local zoning authority
- Construction Documents detail location and type of alternative transportation accommodations
- Verification by Project Manager

SP 4: Paved Areas Heat Island Management

5 points**Purpose**

Reduce heat island effect in hardscape areas by minimizing paved area or incorporating less heatabsorptive materials.

Criteria

Retain only existing hardscape areas within project boundary.

Material for new hardscape areas, such as walkways, plazas and parking lots has a solar reflective index (SRI) of 29 or greater. New concrete is an example of a material that typically meets the criteria, with a typical SRI of around 35. All materials, including pavers and aggregate materials, must meet minimum SRI.

Select one option below:

- A. Remove Existing Non-Historic Paving (Area > 100 sf)**
- B. No New Paving Areas**
- C. Any New Paved Areas Shall be Light Colored Paving Materials**

Resources

U.S. Environmental Protection Agency, Heat Island Effect www.epa.gov

Verification

- Product specification sheet(s) providing SRI value for all hardscape products (other than new grey or white concrete surfaces)
- Construction Documents include location(s) and type(s) of light colored hardscape material ▪

Verification by Project Manager

SP 5: Shade at Least 50% of Hardscape

2 points**Purpose**

Reduce heat island effect by creating shade over paved surfaces, such as parking lots and patio areas.

Criteria

Shade can be in the form of natural tree canopy cover and/or a combination of trees, canopy, or awning that shades hardscape area.

Establish a plan with appropriate heights and widths of planting material, awning or canopy to meet the following criteria:

- Tree shade should be calculated by documenting existing tree canopy coverage - OR - estimating the tree canopy diameter approximately 10 years from the day of tree installation
- Trees cannot be listed on USDA or state agency lists as invasive species
- Provide a shade calculation on the Landscape Plan indicating that at least 50% of hardscape areas will be shaded by trees, building awnings and canopies
 - For the purpose of this calculation, the shaded area for each source of shade is considered to be the same as the area covered by trees, canopies or awnings (direct overhead aerial perspective)

Note: If also attempting SP 16: Tree Planting, then must also meet 2" caliper criteria for associated trees.

Resources

The United States National Arboretum www.usna.usda.gov

Southeast Exotic Pest Plant Council www.se-eppc.org

Verification

- Landscape Plan includes tree specifications, total area of hardscape and percent of area to be covered by shade, as specified in the criteria
- Verification by Project Manager

SP 6: Water Permeable Materials for Hardscape Areas**2-3 Points****Purpose**

Reduce stormwater runoff by providing permeable areas that allow for water infiltration.

Criteria

Hardscape (non-vegetated) areas, such as walkways, plazas, and parking lots consist of water permeable material such as pervious concrete, open-grid pavers or compacted gravel. Sub-base material for these areas must also be permeable.

Select one option:

- A. No New Hardscape (3 points)**
- B. 75% of New Hardscape Areas is Water Permeable (2 points)**

Example Calculation

Calculations should include all hardscape area within the Project Boundary. A Project with 3,500 square feet of permeable hardscape and a total hardscape area of 5,800 square feet would calculate the percent of permeable hardscape as follows:

$$\frac{PSPPSPbPS\ HPPPSSPSS\ APSP\ 3,500\ Ss}{TPePP\ HPPPSSPSS\ APSP\ 5,800\ Ss} = \rightarrow 66.3\%$$

Verification

- Construction Documents indicate type(s) and location(s) of permeable material
- Provide calculations demonstrating percent permeability
- Verification by Project Manager

SP 7: Exterior Lighting Designed to Reduce Light Pollution

1 point**Purpose**

Reduce light pollution and use exterior lighting more efficiently.

Criteria

All site and building facade lighting is certified under the International Dark-Sky Association's Fixture Seal of Approval (FSA) program or qualifies as full cutoff fixtures as defined by the Illuminating Engineering Society of North America (IESNA).

The following exterior lighting can be considered exempt if equipped with an independent control device:

- Specialized signal, directional, and marker lighting associated with transportation
- Advertising or directional signage ▪ Lighting for athletic playing areas
- Lighting used to highlight features of public monuments and registered historic landmark structures or buildings

Resources

International Dark-Sky Association www.darksky.org

Illuminating Engineering Society of North America www.iesna.org

Verification

- Construction Documents clearly outline the location of exterior lighting and specifications for light fixtures
- Verification by Project Manager

SP 8: Greenspace Preservation

Purpose

Preserve natural ecosystems, while providing areas of respite for employees and visitors.

Criteria

Preserve and protect a minimum of 75% of existing natural and vegetative space within the Project Boundary. Calculate the percent of site area preserved within the Project Boundary (excluding the existing building footprint) and provide details on Landscape Plan.

Qualifying greenspace cannot have been graded, cleared or disturbed prior to or by the project pursuing certification, with the exception of that required for minimal utility infrastructure installation.

Create a Greenspace Protection Plan to be carried out during construction that includes the following measures: installation of appropriate barriers prior to tree-clearing activities (such as tree protection fence, wire-backed silt fence, etc.) and a zero trespass policy in the greenspace area during construction activities.

Verification

- Photos of existing project site area prior to construction
- Detail of preserved greenspace area on Landscape Plan and site percentage calculations
- Construction Documents include Greenspace Protection Plan
- Verification by Project Manager

SP 9: Greenspace and Habitat Restoration**5 Points**

Purpose

Create habitat and ecosystems natural to Southeast topography, climate zone, and ecology.

Criteria

Provide necessary restoration measures to return 25% of site area within Project Boundary (excluding the building footprint) to natural conditions through remediation, soil improvements, removal of invasive species, installation of natural and adaptive plant material, wetland repair, natural hydrology restoration, and related techniques that foster support of habitats and ecosystems.

Create a Greenspace Restoration Plan which includes at the following:

- Project Boundary area (excluding the building footprint)
- Restoration area
- Narrative of actions taken to restore the area to natural conditions

Example

A project sets aside a third of the project site area (not including the building footprint) to restore to a natural landscape. All hardscape and invasive species (such as privet and kudzu) were removed, the soil infrastructure was improved/amended for pH and drainage, and the area was planted with native and adaptive plant material.

Verification

- Construction Documents include Greenspace Restoration Plan
- Verification by Project Manager

SP 10: Mature Tree Preservation**5 Points**

Purpose

Use mature vegetation to aid in mitigation of heat island effect and preserve natural landscape.

Criteria

Preserve at least 75% of existing trees that have a chest-height (4 feet above the ground) diameter of 8 inches or more. The tree root zones of the selected trees must be protected with a physical barrier during all site clearing, grading and construction activities.

Create a Tree Preservation Plan that includes the following:

- **Tree Survey**
 - Consult with a certified arborist to assess the existing tree stock prior to establishing the building footprint
 - Determine which trees are in good health and have cultural, native, aesthetic and/or monetary significance
- **Tree Protection**
 - Clearly indicate tree save areas and protection measures in Construction Documents
 - Tree(s) must be fenced around the drip line throughout the construction process with tall, bright, protective fencing
 - Avoid soil being placed on top of any root zone for trees that are designated for preservation. Ensure the protected tree species' needs for growth, sunlight and water integrate well with the new building design

Resources

North Carolina State University, Construction and Tree Protection www.ces.ncsu.edu
Verification

- Tree survey prepared by certified arborist – must contain tree diameters and limit of canopy/drip lines
- Construction Documents include Tree Preservation Plan
- Inspection by Project Manager

SP 11: Tree Planting

2 points**Purpose**

Reduce heat island effect, improve air quality and improve natural ecosystems.

Criteria

Plant a minimum of 12 native trees per acre of developed site area within the Project Boundary (does not include preserved greenspace). For example, if the project site is a ½ acre lot, then a minimum of 6 native trees must be planted. Trees must have a minimum 2 inch caliper (diameter) at planting and a minimum of 200 square feet of planting area per tree.

To ensure long-term successful planting and trees that meet the needs of the space, consult a certified arborist or registered landscape architect to select the appropriate tree species for proposed locations.

The following should be considered when planting new trees:

- Tree growth: height, width, size and shape of canopy
- Deciduous or non-deciduous varieties
- Soil type preferences – amend soil as needed to match soil preferences for selected tree
- Sunlight and water requirements

Resources

Arbor Day Foundation www.arborday.org

Verification

- Landscape Plan details tree planting location, species and caliper for each added tree ▪

Verification by Project Manager

SP 12: Stormwater Management Plan

5 points**Purpose**

Maintain the natural hydrologic cycle, prevent an increased risk of flooding, prevent stream erosion and protect water quality.

Criteria

Work with a civil engineer and/or registered landscape architect to create a Stormwater Management Plan which incorporates Low Impact Development Best Management Practices (LID BMP) to decrease stormwater runoff from the site.

The Stormwater Management Plan should integrate native and adaptive landscaping into the design and minimize the dependency on detention. The Plan must also include the area of disturbed site, type and location of LID BMP's, and address the following as applicable to the design:

- Peak discharge control
- Downstream impact (peak flow analysis)
- Treatment of runoff
- Infiltration and the capture/reuse of water on-site as necessary
- Water quality

Percent reduction is based on the project's pre-construction site conditions. Design project site to infiltrate 30% of 1-year, 24-hour storm-generated runoff volume across the site.

Resources:

Urban Design Tools, Low Impact Development www.lid-stormwater.net

National Resources Defense Council, Low Impact Development www.nrdc.org

Verification

- Construction Documents include Stormwater Management Plan
- Verification by Project Manager

Construction Waste Management

CW R1: No Construction Materials Burned or Buried on Jobsite

Purpose

Prevent air and water pollution associated with the burning and burying of construction materials.

Criteria

Construction materials cannot be burned or buried on site.

Verification

- Inspection by Project Manager

REQUIREMENT**CW R2: Construction Waste Management Plan**

Purpose

Create protocols to effectively divert construction waste from landfills through recycling and/or re-use strategies.

Criteria

Create a Construction Waste Management Plan and provide a copy to Project Manager prior to construction.

Clearly post construction waste recycling protocols at job site and on associated containers, educate subcontractors on aspects of the plan that pertains to their work, and enforce these measures to all those involved in construction activities.

Construction Waste Management Plan must include, at minimum:

- Percent of waste diversion planned (by weight)
- List of materials that will be diverted
- Name of the waste hauler(s) and methods of recycling
- Provisions for on-site separation of materials to be recycled - or - separation of recyclable materials by clean-up or waste hauling firm(s)
- List of existing building and other structures demolished as part of the project's scope
- Name of responsible party for sub-contractor training on recycling protocols

Resources

ECLC Construction Waste Management Plan Template www.earthcraft.org

Verification

- Construction Waste Management Plan provided to Project Manager prior to construction

CW 1: Landfill Waste Diversion**3-8 points**

Purpose

Reduce the amount of construction waste sent to landfills through recycling protocols outlined in the Construction Waste Management Plan.

Criteria

Provide receipts or spreadsheet for waste haul services. Receipts or spreadsheet should include the total amount of waste hauled and total amount of waste diverted by weight, as well as a percent breakdown of each type of waste diverted. If providing a spreadsheet, it must be signed by a representative from the waste haul service.

Select one option below:

- A. Divert 50% of Construction Waste (3 points)**
- B. Divert 75% of Construction Waste (5 points)**
- C. Divert Over 90% of Construction Waste (8 points)**

Note: If materials from an existing building/structure demolition are not reused on site, all waste must be included in waste haul numbers. Do not include excavated soil and hazardous materials in the calculations.

Verification

- Provide waste haul receipts or spreadsheet to Project Manager

CW 2: Donation of Existing Building Materials**1 point**

Purpose

Minimize extraction of natural resources and reduce construction waste by donating existing building materials that may otherwise be sent to a landfill.

Criteria

Reduce demolition waste by donating existing building materials for reuse on another building project. The builder must be able to provide photos of material prior to disassembly. The value of the material should be determined based on fair market value for its intended reuse.

The fair market value of all reused/donated material should be at least \$1000.

Verification

- Construction Documents include size and location of existing building
- Provide photographs of material planned for reuse (prior to disassembly)
- Material Reuse Onsite: Include information on reuse application in Construction Documents ▪
Donated Material: Provide receipt(s) from recipient

CW 3: Preservation of 'Complete' Site Structure(s)

2-15 points**Purpose**

Minimize extraction of natural resources and reduce construction waste by preserving complete secondary site structures that are not part of the construction scope of work and may otherwise be demolished and sent to a landfill.

Criteria

At minimum, secondary site structures must be identified on the site plan. Preservation scope of work must be provided to Project Manager. The builder must be able to provide photos of the structure(s) prior to construction and document implementation of preservation plan.

Point determination will be based on site assessment and provided in initial assessment report. More points will be awarded for structures that hold more significance.

Verification

- Construction Documents indicate size and type of existing structure(s)
- Provide photographs of structure(s) planned for reuse (prior to construction) ▪ Inspection by Project Manager

Resource Efficiency

RE R1: Adaptive Reuse of an Existing Building

Purpose

Minimize extraction of natural resources by utilizing existing building stock.

Criteria

Renovate an existing building structure on the project site. The existing building floor area must account for at least 75% of total project floor area. The majority of the building structural shell (roof, walls and floors) must remain intact.

All construction waste generated from demolition in the renovation must be included in waste diversion calculations if attempting CW1: Landfill Waste Diversion.

Verification

- Construction Documents indicate size and location of existing building
- Existing floor area to total floor area calculations (if applicable)
- Photographs of existing building structure planned for reuse (prior to construction) ▪ Inspection by Project Manager

RE R2: Historically Appropriate Replacement Materials

Purpose

Promote the use of replacement materials in a manner that is consistent with the Secretary of the Interior's Standards for Rehabilitation.

Criteria

Per the Secretary of the Interior's Standards for Rehabilitation:

Deteriorated historic features shall be repaired rather than replaced. Where the severity of deterioration requires replacement of a distinctive feature, the new feature shall match the old in design, color, texture, and other visual qualities and, where possible, materials. Replacement of missing features shall be substantiated by documentary, physical, or pictorial evidence.

All replacement materials should abide by this best practice.

Resources

Secretary of the Interior's Standards for Rehabilitation www.nps.gov/tps/standards.htm

National Park Service Preservation Briefs www.nps.gov/tps/how-to-preserve/briefs.htm

Verification

- Provide product specifications and/or calculations
- Inspection by Project Manager

RE 1: Interior Finishes

1-29 points

Purpose

Lessen impact on natural resources and protect existing historic resources by preserving, restoring or repairing existing interior materials.

Criteria

Reduce the amount of new materials used for the building interior through appropriate treatment of existing historic materials.

The following are historic materials typically found in building interiors:

- **Plaster**
 - 75% of Existing Surface Area (5 points)
 - 90% of Existing Surface Area (8 points)
- **Hardwood Flooring**
 - 75% of Existing Surface Area (3 points)
 - 90% of Existing Surface Area (5 points)
- **Interior Doors**
 - 5% of Existing Surface Area (2 points)
 - 90% of Existing Surface Area (4 points)
- **Stair Treads**
 - 75% of Existing Surface Area (1 points)
 - 90% of Existing Surface Area (2 points)
- **Trim Work (Wainscoting, Baseboards, Crown Molding, Door & Window Trim)**
 - 75% of Existing Surface Area (1 points)
 - 90% of Existing Surface Area (2 points)
- **Fireplace Mantles**
 - 75% of Existing (2 points)
 - 90% of Existing (4 points)
- **Hardware (Door Knobs, Hinges, Window Latches)**
 - 75% of Existing (1 points)
 - 90% of Existing (2 points)

- **Fixtures* (Lighting, Sinks, Tubs, Faucets)**

- 75% of Existing (1 points)
- 90% of Existing (2 points)

**In order to be awarded points, existing fixtures that use energy or water must be documented as contributing to project's historic context and, if possible, must be appropriately refurbished for efficiency (i.e. installing low flow aerator on historic faucet, retrofitting existing light fixture with LED bulb)*

Example Calculation

A project has a total of 15,200 square feet of plaster surface area, including all interior walls and ceilings. After the final design, it is determined that a total of 11,856 square feet of plaster surface area is preserved or restored during the project. The percent of preserved/restored area is determined as follows:

$$\frac{\text{Preserved material}}{\text{Total material}} = \frac{11,856 \text{ PS}}{15,200 \text{ PS}} = \rightarrow 77.0\%$$

Verification

- Construction Documents include material locations and surface area calculations or counts
- Inspection by Project Manager

Purpose

Lessen impact on natural resources and protect existing historic resources by preserving, restoring or repairing existing exterior materials.

Criteria

Reduce the amount of new materials used for the building exterior through appropriate treatment of existing historic materials.

The following are historic materials typically found in building exteriors:

- **Windows**
 - 75% of Existing Surface Area (6 points)
 - 90% of Existing Surface Area (10 points)
- **Siding**
 - 75% of Existing Surface Area (3 points)
 - 90% of Existing Surface Area (5 points)
- **Bricks**
 - 75% of Existing Surface Area (2 points)
 - 90% of Existing Surface Area (4 points)
- **Roofing**
 - 75% of Existing Surface Area (1 points)
 - 90% of Existing Surface Area (2 points)
- **Moldings, Casings, & Trims**
 - 75% of Existing Surface Area (1 points)
 - 90% of Existing Surface Area (2 points)
- **Shutters**
 - 75% of Existing (2 points)
 - 90% of Existing (4 points)
- **Canopies**
 - 75% of Existing (1 points) ○ 90% of Existing (2 points)
- **Signage (Ghosting & Historic Advertising)**
 - 75% of Existing (1 points)

- 90% of Existing (2 points)

Example Calculation

A project has a total of 1,000 square feet of historic window surface area. After the final design, it is determined that a total of 940 square feet of historic window surface area is preserved or restored during the project. The percent of preserved/restored area is determined as follows:

$$\frac{\text{Preserved materials}}{\text{Total materials}} = \frac{940 \text{ PS}}{1,000 \text{ PS}} = \rightarrow 99.0\%$$

Verification

- Construction Documents include material locations and surface area calculations or counts
- Inspection by Project Manager

Durability and Moisture Management

DU 1: Covered Entryways

2 points

Purpose

Reduce potential for water intrusion at building entryways.

Criteria

Retain all existing overhangs at least 3 feet wide at all building entrances.



Verification

- Construction Documents
- Inspection by Project Manager

Purpose

Reduce potential for damage due to leaks inside the building.

Criteria

Address areas of potential water leakage to the building interior caused by mechanical sources.

Perform all water leak prevention measures below:

A. Water Heaters

All water heater tanks must have Temperature Pressure Relief (TPR) valves, as well as drains or drain-pans that capture overflow or leaks, and that are directed to either a combined plumbing drainage system or a drain line to the building exterior.

B. HVAC Condensate

In the HVAC contract, include a provision to have the condensate drain lines and emergency drain pans tested after installation for all systems on roof or within building envelope. Condensate drain lines that drain to the exterior must be properly piped away from the building.

C. Condensation Prevention for Cold Water Pipes

Insulate all cold water pipes located inside conditioned spaces and in interstitial locations (e.g. in walls, floor cavities, etc.) with a minimum of 1/2" insulation or R-2 equivalent.

D. Freeze Protection for All Water Pipes

For any plumbing piping that is located outside of conditioned space (i.e. the building thermal envelope), install a minimum of 1" insulation or R-4 equivalent on ALL cold and hot water piping. Insulation shall be continuous and sealed, with no gaps or breaks.

Verification

- Construction Drawings detail condensate drain line and emergency drain pan test requirements
- Photos of drain line and emergency drain pan tests
- Inspection by Project Manager

Indoor Air Quality

IAQ R1: Minimum Outside Air Requirements

Purpose

Provide sufficient outside air to promote good indoor air quality.

Criteria

Commercial projects must provide outside air either prescriptively or per ASHRAE 62.1-2019.

Residential projects must provide outside air per ASHRAE 62.2-2010.

Select one option below:

A. Prescriptive Outside Air Requirements

Introduce outside air based on space type and square footage. Refer to [Appendix E: Prescriptive Outside Air Requirements](#) for a table of prescriptive outside air CFM requirements according to space type.

B. Meet ASHRAE Standard 62.1-2019, Ventilation for Acceptable Indoor Air Quality

Follow the requirements for outside air as outlined in ASHRAE 62.1-2019.

Resources

American Society of Heating, Refrigerating and Air-Conditioning Engineers (ASHRAE) www.ashrae.org

Verification

- Construction Documents indicate prescriptive or ASHRAE 62.1-2019 ventilation calculations for commercial buildings or ASHRAE 62.2-2010 for residential projects
- Outside air flow rates confirmed by Test and Balance Report (per [IAQ R7: Provide Test and Balance Report](#))

IAQ R2: Minimum Building Exhaust Requirements

Purpose

Prevent indoor air contamination from pollutant sources located within the building.

Criteria

The following are minimum exhaust ventilation requirements:

- **Exhaust Rates and Locations are Consistent with ASHRAE Standard 62.1-2019**
Refer to Table 6-4 in ASHRAE Standard 62.1-2019.

Residential projects must provide exhaust air per ASHRAE 62.2-2010.

- **Automatic Controls**
 - Specify and install automatic controls (such as an occupancy sensor, timer control or air handler interlock) in areas of high humidity to ensure exhaust fans run sufficiently to remove unwanted humidity
 - Specify and install automatic shut-off controls (timer controls or vacancy sensors) to turn off ALL exhaust ventilation when building is not occupied

Resources

American Society of Heating, Refrigerating and Air-Conditioning Engineers (ASHRAE) www.ashrae.org

Verification

- Construction Documents indicate locations and rates of exhaust, locations of high humidity automatic controls, and location of automatic shut-off controls
- Inspection by Project Manager

IAQ R3: Minimize Indoor Air Contamination

Purpose

Reduce indoor air pollutants through filtration and equipment location.

Criteria

Include the following requirements on Mechanical Plans:

- **MERV 8 Filter or Better**
The installed air filter/cleaner on all systems shall have a Minimum Efficiency Reporting Value (MERV) of 8 or higher. Filter must be accessible by building occupants. *Not required for residences
- **Locate Outside Air Intakes Away from Contaminant Sources**
Intakes must be located at least 15 feet from moderate contaminant sources (such as exhaust outlets, garbage pick-up/dumpster areas and garage entries) and 25 feet from high contaminant sources (such as truck loading docks, vehicle idling areas, and high vehicle traffic areas).
- **No Air Handler Equipment in Garage, Parking Decks, or Loading Dock Areas**
Air handler and all associated supply and return ductwork must be isolated from garage, parking decks, loading docks, or other areas of high potential of vehicle exhaust contaminants.

*Existing equipment may be exempted from the above requirements on a case-by-case basis.

Verification

- Construction Documents indicate locations and types of filters, locations of outside air intakes, and location of air handling equipment
- Inspection by Project Manager

IAQ R4: Materials Protection Plan

Purpose

Reduce risk of poor indoor air quality caused by material contamination during construction.

Criteria

Minimize the exposure of building materials to moisture, UV (Ultraviolet) radiation, and other factors that may degrade or promote mold growth on the materials. Create and enforce protocols for the order, delivery, acceptance and on-site protection of materials. The plan must be communicated to all trades/sub-contractors before and during construction.

At a minimum, the Materials Protection plan should include:

- Staged delivery, with materials covered, elevated and protected from moisture and dust
- No paper-faced drywall installed until building is fully dried in
- All ductwork in building (staged or installed) is protected from dust and debris until all sanding, grinding and polishing activities are complete
- If the air handlers are used during construction and/or building flush-out, then MERV 8 filtration must be used on all air handlers and all must be replaced prior to occupancy

Resources

ECLC Materials Protection Plan Template www.earthcraft.org

Verification

- Construction Documents include Materials Protection Plan
- Ongoing inspections by Project Manager

IAQ R5: Sealed Combustion Equipment

Purpose

Reduce risk of carbon monoxide exposure.

Criteria

ALL gas-fired equipment, including (but not limited to) fireplaces*, furnaces, and water heaters, must either be sealed combustion and directly vented - OR - located 100% outside of the building envelope.

*Not required on existing historic masonry fireplaces. Operable fireplaces require installation of carbon monoxide sensor. Inoperable fireplaces must be air sealed.

Verification

- Construction Documents indicate location and type of gas-fired equipment
- Inspection by Project Manager

IAQ R6: No New Vapor Impermeable Wall Coverings

Purpose

Reduce potential for mold growth caused by vapor impermeable interior wall finishes.

Criteria

No vapor impermeable wall coverings allowed (e.g. vinyl wall covering material). Perforated wall coverings are acceptable.

Verification

- Manufacture Specifications

IAQ R7: Carbon Monoxide Detector(s) Installed

Purpose

Reduce risk of carbon monoxide (CO) poisoning.

Criteria

If project includes any combustion equipment or has an attached garage, install carbon monoxide detectors per manufacturer's instructions (minimum one per floor).

Verification

- Inspection by Project Manager

IAQ 1: Decoupled Ventilation

5 points**Purpose**

Reduce energy consumption by effectively treating outside air separately from the heating and cooling system.

Criteria

Decouple outside air introduction from the building's heating and cooling systems by installing a dedicated outside air system (DOAS) for at least 50% of outside air requirements. Ventilation air must be pre-conditioned before it is introduced into heating and cooling system or conditioned space.

Consider pre-conditioning strategies such as energy recovery ventilation (ERV) or indirect evaporative cooling.

Verification

- Construction Documents indicate DOAS and ventilation pre-conditioning strategies ▪

Inspection by Project Manager

IAQ 2: Demand Control Ventilation

5 points**Purpose**

Maintain air quality and decrease energy consumption by delivering outside air based on occupancy.

Criteria

For high occupancy spaces that are greater than 500 square feet in size (e.g. training rooms, classrooms, cafeterias and auditoriums), provide wall-mounted carbon dioxide (CO₂) sensors located on the wall between 3 and 6 feet above the finished floor. CO₂ sensors must be integrated into the ventilation system controls to introduce additional outside air when CO₂ concentration is greater than 1000 parts per million (ppm).

Note: While it is encouraged to consider demand control ventilation for K-12 classrooms, they may be excluded from meeting the criteria for high-occupant spaces.

Definitions

High Occupancy Spaces - rooms with an occupant density of 40 people or more per 1000 square feet (i.e. 25 square feet or less per person). Refer to ASHRAE Standard 62.1-2007, Table 6-1 for Default Occupant Density Values.

Resources

American Society of Heating, Refrigerating and Air-Conditioning Engineers (ASHRAE) www.ashrae.org

Verification

- Construction Documents indicate locations of CO₂ sensor controls
- Inspection by Project Manager

IAQ 3: Filter Replacement Sensor Alarm**1 point**

Purpose

Provide sensors to alert building occupants when filtration media should be replaced to maintain indoor air quality and system efficiency.

Criteria

For all ducted systems over 2 tons, provide sensor alarms (such as a static pressure sensor) to alert occupants or facilities staff when the filtration media is in need of replacement.

Verification

- Construction Documents include types and location of filter replacement sensor alarms

IAQ 4: Range Hoods Include Dampered Make-up Air

5 points**Purpose**

Provide make-up air to mitigate negative pressurization caused by large range hood exhausts.

Criteria

All range hoods shall be vented directly to the outdoors. Intentional make-up air shall be provided for any range hood rated at greater than 500 CFM and deliver at least 50% of the exhausted air volume.

Verification

- Construction Documents indicate range hood exhaust and make-up air rates
- Inspection by Project Manager

IAQ 5: Whole Unit Ventilation System**2-5 Points****Purpose**

Provide whole building ventilation for residences that includes additional design for humidity control, filtration, and/or circulation.

Criteria:

Choose one of the following whole building ventilation systems, with whole building outdoor air CFM designed, installed, and verified per ASHRAE 62.2-2010:

- Energy Recovery Ventilation (ERV) (2 points)
- Supply system integrated with central HVAC system (2 points)
 - If HVAC fan is used for 100% of ventilation delivery, fan must be variable speed
 - If separate supply intake fan is used, outdoor supply air must be filtered by a minimum MERV 6 filter prior to entering HVAC system. Filter must be easily accessible for maintenance and replacement.
- Supply system integrated with dehumidification (5 points)

Verification

- Construction Documents indicate selection of ventilation equipment
- System visually verified by EarthCraft Technical Advisor on-site

IAQ 6: Better Filters**2-4 points**

Purpose

Equip HVAC systems with improved filters for particulate capture in indoor air

Criteria

Design HVAC systems for higher MERV filters:

- MERV 11, ≥ 2 " thick (2 points)
- MERV 13, ≥ 4 " thick (4 points)

Verification

- Field verify filters at final inspections

IAQ 7: Indoor Air Flush-Out Prior to Occupancy**4 points**

Purpose

Reduce adverse health risks commonly associated with material off-gassing and post-construction particulates.

Criteria

Despite attempts to reduce the amount of Volatile Organic Compounds (VOCs) in applied products during construction, it is typical for building materials to off-gas during the first weeks or months after construction completion, and . In addition, a considerable amount of particulate matter can remain in the air following construction. Performing an indoor air flush-out can reduce risk of occupant exposure.

Upon substantial completion of construction (after all sanding, finishing, carpet and furniture installation activities are complete) and before building occupancy, provide at least 200 air changes to reduce occupant exposure to particulates and chemical off-gassing. All interior doors must be opened for the duration of the flush-out.

Perform the building flush-out using one or a combination of the following procedures:

- **Flush-out with HVAC Equipment**
 - Install a minimum of MERV 8 filtration on all air handlers and replace ALL with clean filtration media prior to occupancy
 - Ensure all outside dampers are 100% open
 - Set fan setting to "on" (not automatic) to ensure air handler is running continuously
 - Run for prescribed hours determined by ECLC Indoor Air Flush-out Calculator (after construction/prior to occupancy)

- **Flush-out with Supplemental Fan Equipment**
 - Pressurize or depressurize
 - Add MERV 8 filter to all air intake locations, including operable windows (if applicable)
 - Run for prescribed hours determined by ECLC Indoor Air Flush-out Calculator (after construction/prior to occupancy)

Definitions

Air Change - replacement of the entire indoor air volume of a building with outside air.

Resources

ECLC Program Worksheet - ECLC Indoor Air Flush-out Calculator www.earthcraft.org

Verification

- Construction Documents indicate Indoor Air Flush-out procedures
- Indoor Air Flush-out Calculations
- Photographs of flush-out procedure

IAQ 8: Air System Balanced within 10% of Design

5 points**Purpose**

Ensure HVAC systems are providing airflow rates as designed.

Criteria

Retain an independent, third-party testing agent to perform a Test and Balance of the system's airflow for all ductwork. The report must demonstrate that the air system is balanced to within +/- 10% of the Design Air Flow Values.

At minimum, the report should include the following values:

- Supply airflow for each air handling unit and each register
- Return airflow for each air handling unit and each register
- Outside airflow for each air handling unit
- Exhaust rates per fan and each register
- Minimum and maximum airflows for terminal units

Verification

- Copy of Test and Balance Report (performed by third-party testing agent)

IAQ 9: Radon Exposure Prevention**3 points**

Purpose

Prevent occupant exposure to radon.

Criteria

Project team shall conduct a radon test of the building and provide test results to the building owner. Radon test must comply with EPA guidelines. If test indicates a radon concentration greater than 4 picocuries per liter, project must follow EPA guidelines to reduce radon levels.

Resources

U.S. Environmental Protection Agency www.epa.gov

Verification

- Construction Documents include soil gas vent system
- Provide radon test results to owner and Project Manager
- Inspection by Project Manager

IAQ 10: Walk-off Mats

1 point**Purpose**

Reduce particulate matter entering building.

Criteria

Install interior or exterior walk-off mats that are 6 feet long in the direction of travel at the primary entrance(s). Mats may either be a permanently installed system or roll-out mats that are cleaned on a weekly basis. A minimum 1-year service contract is required for cleaning of roll-out mats.

Verification

- Service contract for roll-out mats
- Inspection by Project Manager

IAQ 11: Install Corrosion Proof Rodent Screens**1 point**

Purpose

Reduce potential for insects and rodents to introduce pollutants into mechanical system.

Criteria

Install corrosion proof rodent screens for all exterior mechanical openings (e.g. outside air intakes, exhaust, etc.).

Verification

- Inspection by Project Manager

IAQ 12: Any New Paints, Stains and Sealers are Low-VOC**2-4 points****Purpose**

Reduce building occupant exposure to volatile organic compounds (VOCs).

Criteria

Include maximum VOC limit for paints, stains and sealer products in Construction Documents and ensure that site-applied products to not exceed the maximum VOC limit specified.

Select one option below:

A. Low-VOC (2 points)

Product Type	VOC Limit	Standard
Primers	100 g/L	GS-11
Flat Topcoat Paint	50 g/L	GS-11
Non-flat Topcoat Paint	100 g/L	GS-11
Anti-corrosive Paints and Primers	250 g/L	GS-11
Stains	250 g/L	GS-47
Sealer	200 g/L	GS-47
Waterproof Sealer	250 g/L	GS-47

B. Ultra Low-VOC (4 points)

Product Type	VOC Limit
Primers	50 g/L
Flat Topcoat Paint	50 g/L
Non-flat Topcoat Paint	50 g/L
Anti-corrosive Paints and Primers	100 g/L
Stains	100 g/L
Sealer	100 g/L
Waterproof Sealer	100 g/L

Note: The VOC thresholds for paints, stains and sealers apply only those used on the interior of the building.

Resources

Green Seal, GS-11 Standard for Paints and Coatings (Third Edition) and GS-47 Standard for Stains and Finishes (First Edition) www.greenseal.org

Verification

- Product MSDS (Material Safety Data Sheet(s)) for site-applied paints, stains and sealers

IAQ 13: Any New Adhesives are Low-VOC**2 points****Purpose**

Reduce building occupant exposure to volatile organic compounds (VOCs).

Criteria

Include a maximum VOC limit of 100g/L for the following adhesives and ensure that site applied adhesives do not exceed the 100 g/L limit specified:

- Carpet adhesive
- Carpet pad adhesive
- Wood flooring adhesive
- Rubber floor adhesive
- Subfloor adhesive
- Ceramic tile adhesive
- Vinyl composition tile (VCT) adhesive
- Drywall and panel adhesive
- Cove base adhesive
- Multipurpose construction adhesive

Note: The VOC threshold of 100 g/L applies only adhesives used on the interior of the building.

Resources

South Coast Air Quality Management District (SCAQMD), Rule 1168 Adhesive and Sealant Applications (Amended January 7, 2005) www.aqmd.gov

Verification

- Product MSDS (Material Safety Data Sheet(s)) for site-applied adhesives

IAQ 14: Any New Carpet Systems CRI Green Label Plus Certified 2 points

Purpose

Reduce building occupant exposure to volatile organic compounds (VOCs).

Criteria

Installed carpet and associated adhesives are certified by the Carpet and Rug Institute's (CRI) Green Label Plus program.

**Resources**

The Carpet and Rug Institute www.carpet-rug.org

Verification

- Product Specifications indicating CRI Green Label Plus certification

IAQ 15: Any New Flooring FloorScore or Greenguard Certified **2 points**

Purpose

Reduce building occupant exposure to volatile organic compounds (VOCs).

Criteria

All of the following installed non-carpeted flooring is certified by either FloorScore or Greenguard Environmental Institute:

- Bamboo flooring
- Cork floor
- Hardwood flooring
- Linoleum flooring
- Laminate flooring
- Porcelain tile
- Rubber flooring
- Rubber wall base
- Sheet Vinyl Flooring
- Vinyl composition tile (VCT)
- Vinyl tile

Resources

The Resilient Floor Covering Institute www.rfci.com

Greenguard Environmental Institute www.greenguard.org

Verification

- Product Specifications indicating FloorScore or Greenguard certification

IAQ 16: Any New Composite Wood Added Urea-Formaldehyde Free 1 point

Purpose

Reduce building occupant exposure to urea-formaldehyde.

Criteria

All interior composite wood products contain no added urea-formaldehyde (e.g. particleboard, MDF, plywood, laminated shelving, etc.).

Verification

- Product MSDS (Material Safety Data Sheet(s))

IAQ 17: Any New Cavity Insulation Formaldehyde-free

1 point

Purpose

Reduce building occupant exposure to formaldehyde.

Criteria

All cavity insulation must be free of formaldehyde. Examples of formaldehyde-free insulation include spray foams, cellulose and certain fiberglass products.

Verification

- Product MSDS (Material Safety Data Sheet(s))

IAQ 18: Building Achieves Positive Pressure

2 points**Purpose**

Avoid contaminant infiltration caused by negatively pressurized spaces.

Criteria:

Design the building so that the overall building pressure, with all air moving equipment in normal operation, is slightly positively pressurized.

During the Final Site Visit, the Project Manager will test the building pressure differential. If a negative indoor pressure of more than 3 Pascals with respect to the outdoors is discovered, the Project Manager will advise the project to make adjustments to supply and/or exhaust rates.

Verification

- Building Pressure Differential Test by Project Manager on Final Site Visit

High Performance Building Envelope

BE R1: Meet ASHRAE Standard 90.1-2019 for Alterations

Purpose

Meet minimum energy efficiency standards for any alteration to the building thermal envelope.

Criteria

Where alterations are being performed, they must meet or exceed ASHRAE Standard 90.1-2019 energy requirements for all building thermal envelope components, including roof, walls, floors, glazing, and doors. Note that local energy code standards may be more stringent.

Architectural Drawings must indicate insulation values for each thermal envelope component which will be altered as part of scope of construction.

Refer to ASHRAE 90.1-2019 prescriptive envelope insulation requirements. This requirement only applies to alterations to the building's thermal envelope that do not negatively impact historic material.

Resources

American Society of Heating, Refrigerating and Air-Conditioning Engineers (ASHRAE) www.ashrae.org

COMcheck Software
www.energycodes.gov

Verification

- Inspection by Project Manager

BE R2: Envelope Air Tightness Performance Test

Purpose

Ensure envelope construction meets air tightness requirements through verified performance testing.

Criteria

All program participants are required to have an Air Tightness Performance Test as part of their initial site assessment and during the Final Site Visit. The performance test will be performed using blower door diagnostic equipment and test results at final must meet one of the following two performance metrics:

- A. Commercial Buildings: Be no greater than .50 ELR₇₅ (Envelope Leakage Ratio) or Achieve 15% leakage reduction
- B. Residential units achieve ≤ 7 ACH₄₀ or $\geq 20\%$ reduction in air leakage

Additional points can be achieved for better performance results (refer to [BE 1: Advanced Air Tightness Performance Test Results](#)).

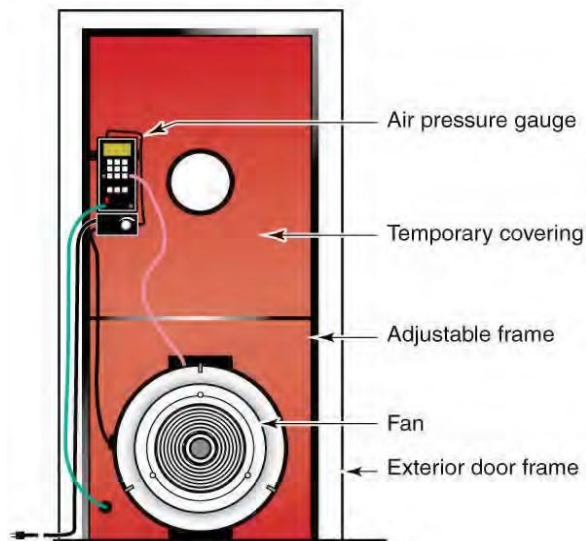

Blower Door Assembly

ENVELOPE AIR TIGHTNESS PERFORMANCE TEST

During the test, all HVAC systems and combustion appliances will be turned off and the building will be depressurized to 75 Pascals (Pa). Two tests will be performed:

- 1) *Blower Door test with intentional building penetrations (such as exhaust and outside air intakes) unsealed*
- 2) *Blower Door test with intentional penetrations temporarily sealed*

The second of the two tests will determine the air tightness of the building's thermal envelope assembly. The difference between the two test results will indicate the quantity of air leakage occurring through intentional penetrations.

Definitions

ELR₇₅ (Envelope Leakage Ratio at 75 Pa)

The Envelope Leakage Ratio (ELR) is the quantity of air leakage expressed in cubic feet per minute at a 75 Pa pressure difference (CFM₇₅) divided by the total square footage of the building's thermal envelope (SFBE).

CFM₇₅ (Cubic Feet per Minute at 75 Pa)

The volume of air in cubic feet per minute moved through a fan that is set to a 75 Pa pressure differential between conditioned and unconditioned space. **SFBE (Square Footage of Building Envelope)**

The total square footage of building's thermal envelope: Building Envelope Floor + Exterior Insulated Wall + Insulated Ceiling/Roofline.

Pascal

A Pascal (Pa) is a small metric unit of pressure and is commonly used in lieu of inches of water column (1" water column = 248 Pa).

Building Thermal Envelope

The building thermal envelope is the portion of the building envelope that is comprised of the continuous air barrier and insulation and separates conditioned space from unconditioned space.

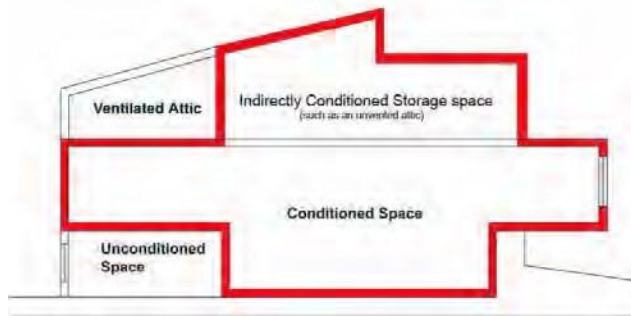

Verification

- Envelope Performance Test by Project Manager on Final Site Visit

BE R3: Air Barrier Penetrations Sealed and Air Tight

Purpose

Improve overall envelope performance and minimize energy loss by sealing penetrations through the continuous air barrier.

Criteria

Detail penetration sealing requirements in Construction Documents. During construction, ensure all sub-contractors are aware of penetration sealing requirements. Failure to properly seal all penetrations may severely impact [BE R3: Envelope Air Tightness Performance Test](#).

All penetrations through the continuous air barrier (roofs, walls and floors) must be sealed, caulked, gasketed and/or taped.

Pay particular attention to sealing the following “problem areas” at the continuous air barrier:

- Window and door rough openings
- Penetrations through rim/band joists
- Penetrations at covered entryways connecting conditioned and unconditioned space
- Plumbing and electrical penetrations
- HVAC penetrations, such as those for refrigerant lines, ducts, and exhaust
- Attic pull-down stairs, scuttle holes and kneewall access
- Recessed lighting in insulated ceilings - must be ICAT-rated (Insulation Contact Air Tight)
- Speaker and sprinkler head penetrations
- Chases
- All other penetrations in the building thermal envelope



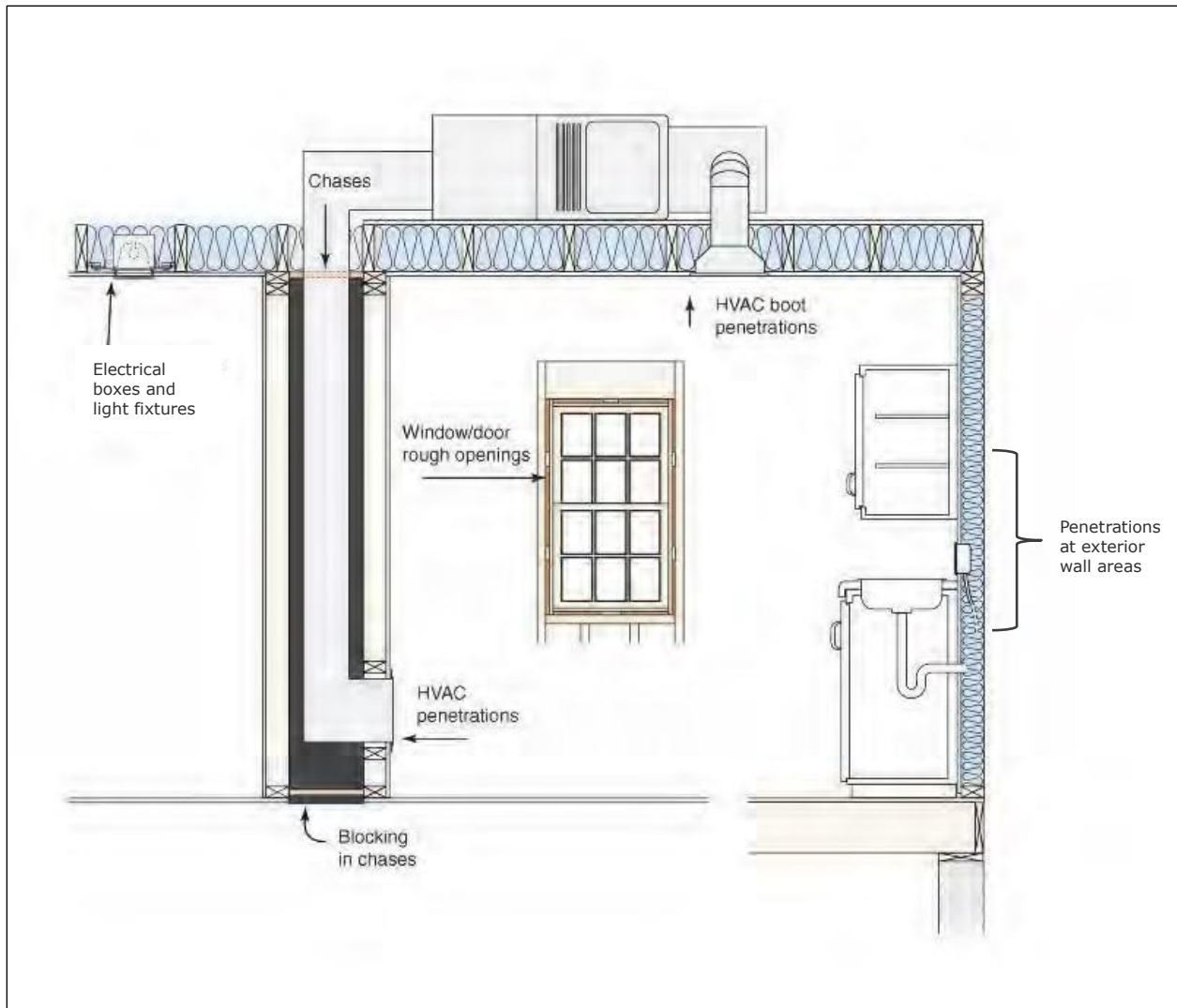

Typical Air Barrier Penetrations at Building Thermal Envelope

Verification

- Construction Documents clearly detail sealing requirements for air barrier penetrations
- Provide photos of sealed penetrations that cannot be visually verified
- Inspection by Project Manager

BE R4: No Power Attic Ventilation

Purpose

Avoid using an energy source for attic ventilation.

Criteria

Vented attics should be passively ventilated.

Verification

- Inspection by Project Manager

BE R5 Insulation at all accessible locations/where impacted

Purpose

Provide complete insulation coverage for exterior surfaces

When building cavities are exposed and new insulation installed, provide minimum R-values. If existing wall cavities are wider than 3.5 inches, install new insulation material to completely fill the cavities without compression.

Residential buildings/units:

- Exterior walls $\geq R-13$, Grade I
 - When metal/steel framed buildings have new exterior cladding installed, provide $\geq R-7$ continuous exterior insulation
- Attic insulation $\geq R-38$, Grade I cavity insulation
 - Projects may choose to provide continuous exterior insulation if a roof is being replaced. Contact EarthCraft program administrator for additional information.
- Accessible floors over unconditioned/exterior locations: $\geq R-19$, Grade I

Commercial Buildings:

- Exterior walls $\geq R-13$, Grade I
 - When metal/steel framed buildings have new exterior cladding installed, provide $\geq R-7$ continuous exterior insulation
- Attic insulation $\geq R-38$, Grade I cavity insulation
 - Projects may choose to provide continuous exterior insulation if a roof is being replaced. Contact EarthCraft program administrator for additional information.
- Accessible floors over unconditioned/exterior locations: $\geq R-19$, Grade I

Verification

- Inspection by Project Manager during pre-drywall and final inspections

BE 1: High Performance Building Energy Modeling**10 points**

Purpose

Complete energy modeling to determine energy efficiency savings opportunities and document anticipated performance.

Criteria

Select one option below:

- A. Building-level energy modeling $\geq 15\%$ savings above ASHRAE 90.1-2019
- B. Unit-level energy modeling meets or exceeds ENERGY STAR Multifamily v1.1 target(s) for each unit type

Verification

- Provide energy modeling reporting at design phase. Submit verified, confirmed energy modeling at final review.

BE 2: Exceed Air Tightness Performance Test Requirement 10-15 points

Purpose

Verify air tightness of building thermal envelope.

Criteria

During the Final Site Visit, an Envelope Air Tightness Performance Test will be administered using blower door diagnostic equipment to determine how well the building envelope performs in terms of air leakage. Points are awarded based on performance test results.

Select one option below:

- C. Measured $ELR_{75} \leq 0.40$ (10 points)
- D. Measured $ELR_{75} \leq 0.30$ (15 points)
- E. Measured ELR_{75} achieves 25% reduction (10 points)
- F. Measured ELR_{75} achieves 40% reduction (15 points)

Verification

- Envelope Air Tightness Performance Test performed by Project Manager on Final Site Visit

BE 3: Exceed Air Tightness Performance Test Requirement **10-15 points**

Purpose

Verify air tightness of building thermal envelope.

Criteria

During the Final Site Visit, an Envelope Air Tightness Performance Test will be administered using blower door diagnostic equipment to determine how well the building envelope performs in terms of air leakage. Points are awarded based on performance test results.

Select one option below:

- A. Measured $ACH_{50} \leq 5$ (10 points)
- B. Measured $ACH_{50} \leq 3$ (15 points)
- C. Measured leakage achieves $\geq 25\%$ reduction (10 points)
- D. Measured leakage achieves $\geq 40\%$ reduction (15 points)

Verification

- Envelope Air Tightness Performance Test performed by Project Manager on Final Site Visit

BE 4: Insulation at Foundation Walls**2 points**

Purpose

Reduce energy loss through correct insulation of foundation walls.

Criteria

Provide a minimum R-5 continuous insulation at foundation walls above grade. Ensure that construction documents appropriately detail insulation protection, termite resistance measures, flashing and air sealing.

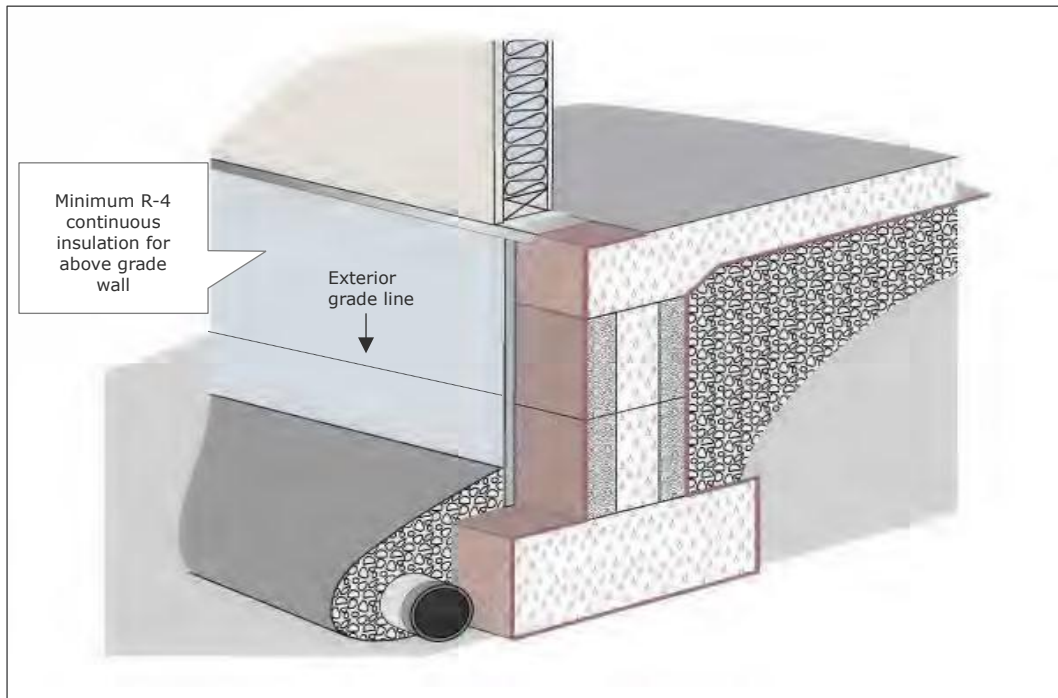

Insulation at Foundation Wall

Verification

- Construction Documents clearly indicate location and R-value of foundation wall insulation ▪
- Inspection by Project Manager

BE 5: Closed Crawlspace**5 points****Purpose**

Minimize energy loss and increase durability by providing better moisture control with a closed crawlspace.

Criteria

Provide a closed crawlspace for the project. Carefully consider moisture management, combustion safety and termite control issues in the design of the crawlspace. Do not attempt a closed crawlspace if project is located within the 100-year flood plain or if historic brick foundation and/or historic brick piers present.

Consider other related point items: ES 7: Air Handlers Located Within Thermal Envelope and ES 8: Ductwork Located Within Thermal Envelope.

Include the following details in the design and construction of the closed crawlspace:

- No venting allowed - all penetrations in crawlspace walls and floor to conditioned space above must be sealed
- Wall connections are sealed with caulk, foam sealant and/or gasket:
 - Foundation stem wall and the sill plate
 - Sill plate and band joist
 - Band joist and subfloor
- Termite shield or sill seal between foundation stem wall and the bottom plate (i.e. sill plate)
- A minimum Class I, 6-mil (0.15 mm) polyethylene vapor retarder must be installed and secured to cover all exposed earth and extended at least 12 inches up foundation wall or above exterior ground grade level - overlap joints at least 12 inches and apply sealant
- Crawlspace walls must be continuously insulated to the following minimum levels (insulation may be located on the interior or exterior surface of the crawlspace walls):
 - Climate Zone 2: R-5.7
 - Climate Zone 3: R-7.6
 - Climate Zone 4: R-9.5
- A 3 inch inspection strip must be included immediately below wood floor joists/sill plate to allow inspection for termites
- Insulated band joists - minimum R-13
- Access doors completely weather stripped and insulated to the same level as the crawlspace walls - ensure access doors have adequate protection from bulk water intrusion
- Install a dehumidification system to maintain relative humidity at levels of <60%

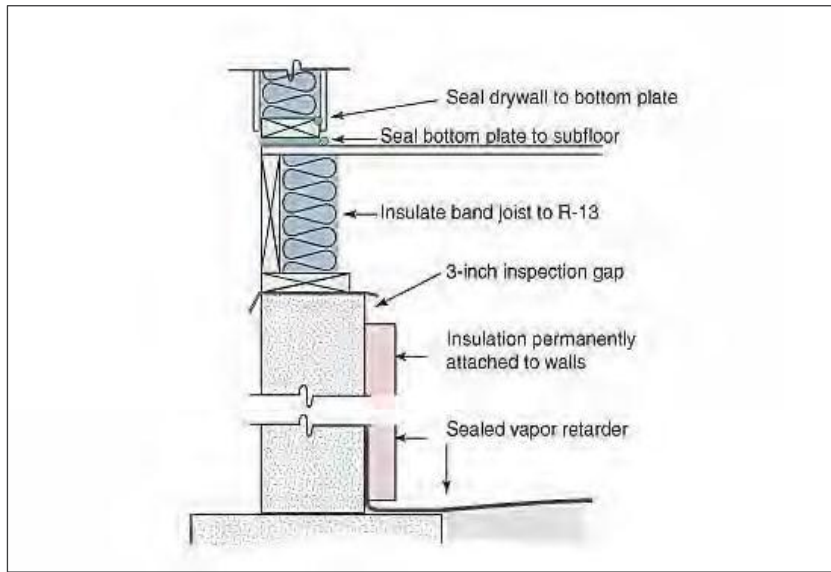

Closed Crawlspace Wall Details

Note: The 2009 IBC does not specifically allow closed crawlspaces (refer to section 1203.3 Under-floor ventilation); however, closed crawlspaces may be installed in accordance with the 2009 IBC section 104.11 Alternative materials, design and methods of construction and equipment. Check with local/state building codes for potential conflicts.

Resources

Advanced Energy
www.crawlspaces.org

Verification

- Construction Documents clearly indicate closed crawlspace details
- Inspection by Project Manager

BE 6: Unvented Attic**10 points****Purpose**

Increase envelope performance and reduce the potential for energy loss/durability issues typically associated with vented attics.

Criteria:

Design and install a continuous air barrier that integrates the wall with the roofline. Insulation should be applied above or under the roof deck and historic fabric should be protected from permanent bonding with spray foam insulation products. Achieving this point item can assist with achievement of [ES 7: Air Handlers Located Within Thermal Envelope](#) and [ES 8: Ductwork Located Within Thermal Envelope](#).

The 2009 International Building Code (IBC) does not specifically allow unvented attics under section 1203.2, Attic spaces; however, the unvented attic approach can be pursued in accordance with the 2009 IBC section 104.11, Alternative materials, design and methods of construction and equipment.

If using air-permeable insulation (e.g. batt insulation) under the roof deck, then additional continuous rigid insulation is required (R-5 for climate zones 2 and 3, and R-15 for climate zone 4). Refer to the 2009 International Residential Code (IRC), section R806.4 for instructions on how to meet criteria.

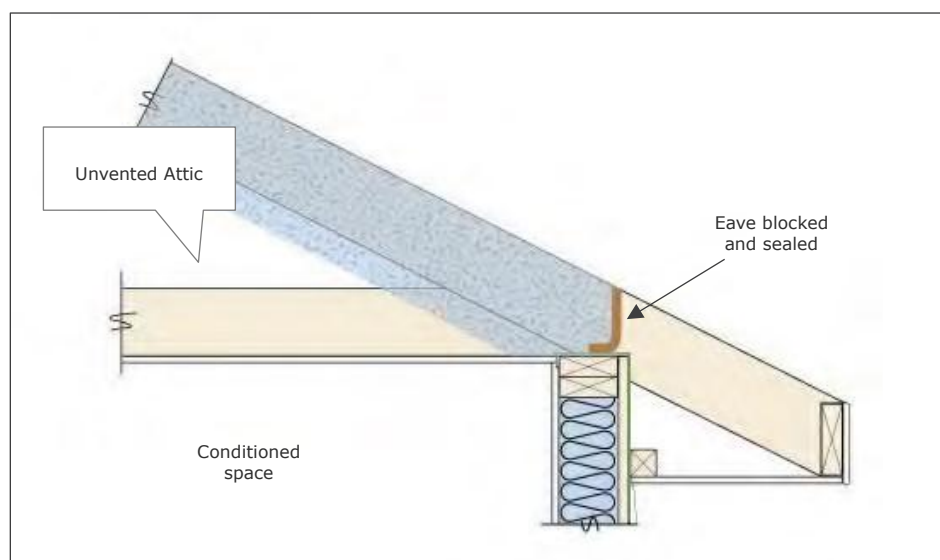

Example: Insulation Applied Under Roof Deck

Note: These points are not applicable for flat roofs or pitched roofs less than 3:12.

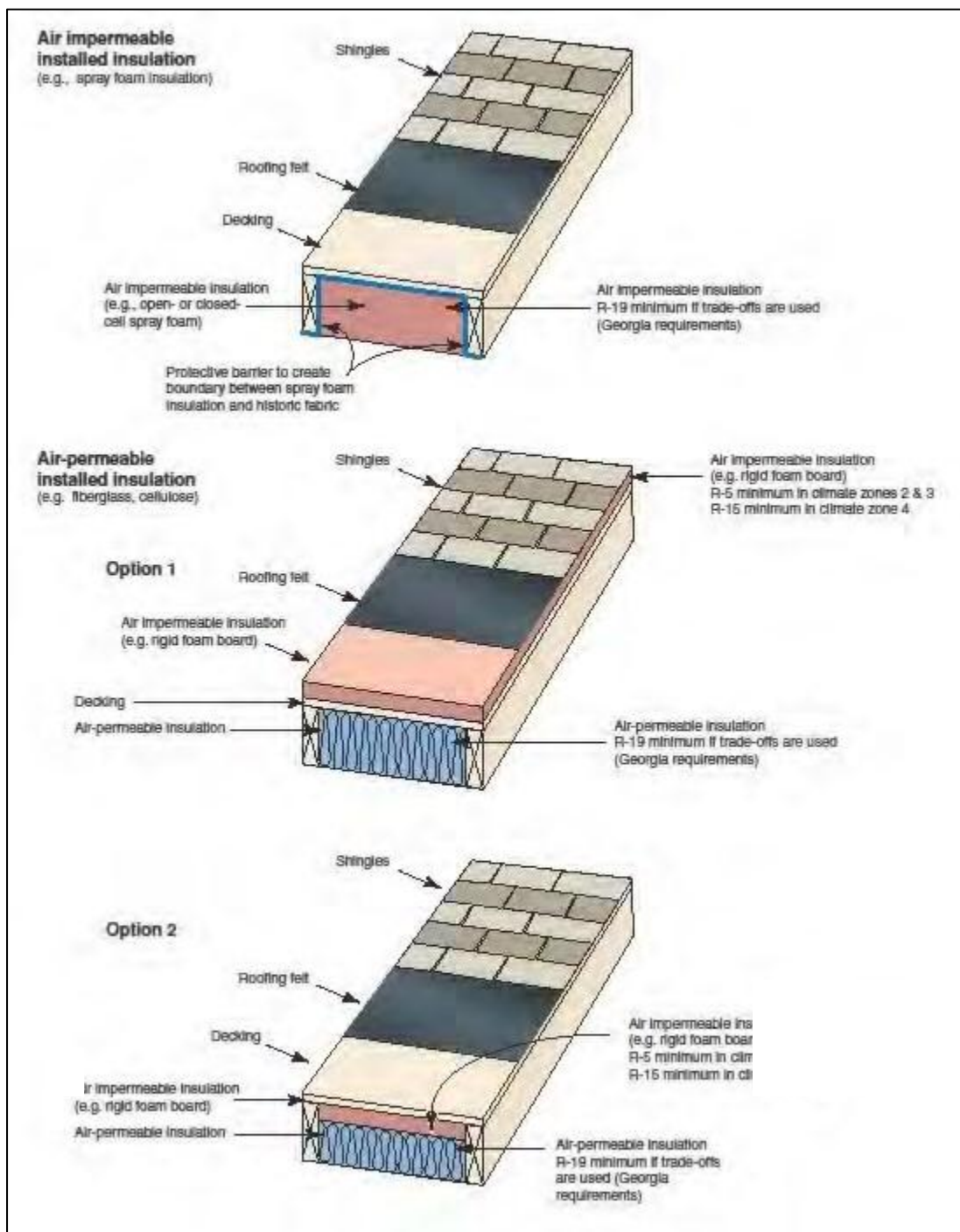

Unvented Attic - Roofline Installed Insulation Options (refer to 2009 IRC)

Resources:ASHRAE Standard 90.1-2007 www.ashrae.org2009 International Building Code and 2009 International Residential Code www.iccsafe.org**Verification**

- Construction Documents clearly detail roof insulation location(s) and R-value(s)
- Inspection by Project Manager

BE 7: Attic Radiant Barrier

3 points**Purpose**

Reduce energy costs and increase comfort by installing a radiant barrier in vented attic assemblies.

Criteria

Install radiant barrier in a manner consistent with manufacturer's specifications.

*Credit will not be awarded for radiant barriers laid on top of ceilings. Radiant barriers must be installed at the roof line.

Verification

- Construction Documents include advanced envelope details
- Opaque wall/roof area to advanced envelope area calculations
- Inspection by Project Manager

BE 8: Cool Roof**3-8 points****Purpose**

Reduce energy loads and “heat island” effect by applying highly reflective roofing materials.

Criteria

A “cool” roof can minimize heat gain, which helps to reduce energy consumption. Install highly reflective material for at least 90% of roofing.

Select one or both options below:

A. Cool Roof Council Qualified Roofing Material (3 points)**B. Minimum Solar Reflectance Index (SRI) (5 points)**

- Steep-sloped roofs (>2:12) - meet SRI of 29 or higher
- Low-sloped roofs (≤2:12) - meet SRI of 82 or higher

Definitions

Solar Reflectance Index (SRI) - a temperature scale calculated from solar reflectance and thermal emittance values used as a metric for comparing the coolness of roof surface types.

Resources

ENERGY STAR www.energystar.gov

Cool Roof Rating Council www.coolroofs.org

Verification

- Roofing Material Specification Sheet(s)
- Inspection by Project Manager

BE 9: Improve Vertical Glazing Performance**1-8 points****Purpose**

Reduce heat gain and loss through the building envelope glazing and improve air sealing through installation of historically appropriate measures.

Criteria

Specify and install historically appropriate storm windows, interior shading, exterior shading devices, and/or clear window films.

Select one option below:

- A.** Storm Windows for 95% of historic window area (5 points) **B.**
Exterior Shading Devices (i.e. operable shutters) (2 points)
- C.** Interior Shading Devices (i.e. blinds) (1 point)
- D.** Clear window film (Low-E) (2 points)
- E.** Replacement of non-historic windows with windows that exceed ASHRAE 90.1-2007 requirements (4 points)

Resources

National Fenestration Rating Council www.nfrc.org

Verification

- Construction Documents indicate U-factor for all glazing components
- Provide NFRC label (leave label attached to glass for verification) or Certificate of Compliance for field-fabricated glazing (e.g. storefront or curtain wall systems)
- Inspection by Project Manager

Energy Efficient Building Systems

ES R1: Provide Heating and Cooling Load Calculations and Selections Report for New Equipment

Purpose

Utilize load calculations for the purpose of appropriately sizing heating and cooling systems.

Criteria

Provide load calculations for heating and cooling system selection. Load calculation software should be approved for commercial use and follow standards such as ACCA Manual N or ASHRAE Handbook of Fundamentals and must include accurate inputs for the following:

- Outdoor design temperatures, based on ASHRAE weather tables and geographical location
- Building thermal envelope assembly, including R-values and U-factors
- Lighting loads, with separate inputs for exempt lighting loads
- Ventilation load
- Infiltration/building tightness (*note that ECLC requires a "tight" envelope – maximum 0.50 Envelope Leakage Ratio at 75 Pa ($ELR_{75} = CFM_{75}/SFBE$ – refer to [BE R2: Envelope Air Tightness Performance Test](#) for more information)*)
- Other internal loads
- Occupancy schedules

Note: If installed system cooling capacity is within 95% to 115% of calculated load, then additional points may be earned under [ES 1: Right-sized Equipment](#).

Resource

American Society of Heating, Refrigerating, and Air-Conditioning Engineers (ASHRAE) www.ashrae.org

Air Conditioning Contractors of America (ACCA) www.acca.org

Verification

- Heating and Cooling Load Calculation inputs and outputs

ES R2: Commercial: Meet ASHRAE Standard 90.1-2019 for New HVAC Equipment

Purpose

Meet minimum energy efficiency standards for all new heating, ventilating, and air conditioning systems.

Criteria

Project must meet or exceed ASHRAE Standard 90.1-2019 energy requirements for all new heating, ventilating and air conditioning systems using either the Simplified Approach or Prescriptive Path.

Heating systems may not use electric resistance heat as the primary heat delivery source. Gas systems must be sealed combustion, direct vent and/or separate from the occupied spaces.

Select one of the following options:

A. Simplified Approach (refer to ASHRAE Standard 90.1-2019, section 6.3)

To demonstrate compliance, each HVAC system in the building must comply with the requirements listed in ASHRAE Standard 90.1-2019, Section 6.3.2 and sign/complete an ECLC Simplified Approach for HVAC Compliance Certificate.

A project may select the Simplified Approach if the design meets the following conditions:

- Building is 2 stories or fewer in height
- Gross floor area is less than 25,000 square feet

The following is a summary of the fifteen Simplified Approach requirements:

- a) Each system must serve a single zone
- b) Cooling must be packaged or split system (either air or evaporative cooled) and meet minimum equipment efficiencies
- c) Economizers may be required in certain circumstances
- d) Heating must be packaged or split system heat pump, gas, electric or hot water and meet minimum efficiencies
- e) Outside air requirements must be less than 3000 CFM and less than 70% of supply air quantity
- f) Manual changeover or dual set point thermostat is required
- g) When possible, heat pump feature will always provide heating
- h) No reheat or simultaneous heating and cooling allowed for humidity control
- i) Provide control for systems larger than 15,000 Btu/h and $\frac{3}{4}$ HP fan motor requires a time clock
- j) Meet minimum piping insulation and weather protection requirements
- k) Meet minimum ductwork and plenum sealing and insulation requirements
- l) Ducted systems must be air balanced in accordance with accepted industry procedures

- m) Separate thermostats must be interlocked to prevent simultaneous heating and cooling
- n) Exhaust systems over 300 CFM must have gravity or motorized dampers
- o) Systems greater than 10,000 CFM must have optimum start controls

Prescriptive Path (refer to ASHRAE Standard 90.1-2019, section 6.5)

For projects following the Prescriptive Path, compliance must be demonstrated with *COMcheck*. Note that simultaneous heating and cooling/reheat is not allowed in most cases by energy code and is strongly discouraged by the ECLC Program.



Refer to [Appendix A: COMcheck Overview](#) for more information about *COMcheck* and [Appendix C: COMcheck Mechanical](#) for a guide to entering information into *COMcheck* for mechanical systems.

MR: Major Renovation projects must meet all ASHRAE requirements. Refer to ASHRAE Standard 90.12019, section 6.1.1.3 for potential exceptions.

Resources

American Society of Heating, Refrigerating and Air-Conditioning Engineers (ASHRAE) www.ashrae.org

COMcheck Software
www.energycodes.gov

ECLC Simplified Approach for HVAC Compliance Certificate www.earthcraft.org

Verification

- Construction Documents include Mechanical Plans and Schedules
- Simplified Approach: Signed/completed ECLC Simplified Approach for HVAC Compliance Certificate – submitted prior to start of construction
- Trade-Off Option: *COMcheck* File, and a signed/completed *COMcheck* Mechanical Compliance Certificate – submitted prior to start of construction
- Inspection by Project Manager

ES R3: Residential: Meet minimum efficiency standards for HVAC systems

Purpose

Install new HVAC systems that meet minimum efficiency standards

Criteria

Select system HVAC systems based on fuel and system type:

- A. Gas furnace is sealed combustion, $\geq 95\%$ AFUE
- B. Heat pump efficiency is ≥ 8.8 HSFP/ ≥ 7.5 HSPF2 or equivalent COP
- C. Cooling equipment is ≥ 15 SEER/ $14/3$ SEER2 or ≥ 12 EER

Verification

- Mechanical Submittals, including refrigerant specifications
- Inspection by Project Manager

ES R4: No HCFC or CFC Refrigerants in New Equipment

Purpose

Reduce the use of ozone-depleting refrigerants.

Criteria

No HCFC or CFC based refrigerants in new or replacement HVAC equipment.

Resources

U.S Environmental Protection Agency, HCFC Phaseout www.epa.gov

Verification

- Mechanical Submittals, including refrigerant specifications
- Inspection by Project Manager

ES R5: New Duct System Requirements

Purpose

Ensure new ductwork installed on existing systems meets minimum performance requirements based on installation. Reduce energy loss typically associated with air distribution equipment.

Criteria

- A. Maximum flexible duct run of 25 feet. Support flexible ductwork with minimum 1" thick strapping every 5 feet
- B. R-8 insulation for ductwork in unconditioned space

Ducted systems must meet the following minimum criteria:

- **Duct Design Documentation**
At a minimum, provide a scaled single line drawing that indicates duct layout, duct sizes, outside air intake location(s), and supply/return registers. Design CFM's shall be included and used as the basis for NC R15: Third Party Test and Balance Report.
- **Rigid Supply Trunk**
Design and install all duct systems using the "trunk and branch" configuration. The trunk and branch configuration requires that each HVAC system has at least one rigid supply trunk with multiple, short branch take-offs to each supply register.
- **All Supplies and Returns Must Be Fully Ducted**
Building cavities may not be used as ducts or plenums (e.g. stud cavity, joist space and above-ceiling plenums not allowed).
- **Outside Air Ducting**
Outside air shall generally be ducted directly into the return air plenum to provide for intentional mixing and must have balancing dampers in order to regulate outside airflow. Exceptions for other ventilation systems (e.g. energy recovery ventilators) are permissible.
- **Maximum Flex Duct Run is 25 Feet**
All flex must be supported properly and pulled tight, with no pinching or compression.
- **Solid Connectors for All Flex to Flex Connections**
Use rigid connectors or sleeves on all flex-to-flex duct connections. Flex duct liner must be connected to sleeve using a duct tie and sealed with mastic or mastic tape (mastic tape must be UL181-compliant butyl rubber-backed foil tape).
- **No Ductwork Displaces Insulation in Building Thermal Envelope Walls or Ceilings**
- **Ductwork outside the building's thermal envelope must be insulated with R-6 or better.**
- **Duct System Must be Sealed**
Seal all seams, joints, collars and connections in forced-air delivery systems using mastic or mastic tape (mastic tape must be UL181-compliant butyl rubber-backed foil tape):
 - Supply and return boots
 - Supply and return plenums
 - Duct-to-plenum connections
 - Y-splits, butt joints and boot connections
 - Outside air intakes
 - Filter housing to duct connections

- Air handler condensate, refrigerant line and wire penetrations, and unused holes in the air handling unit cabinet

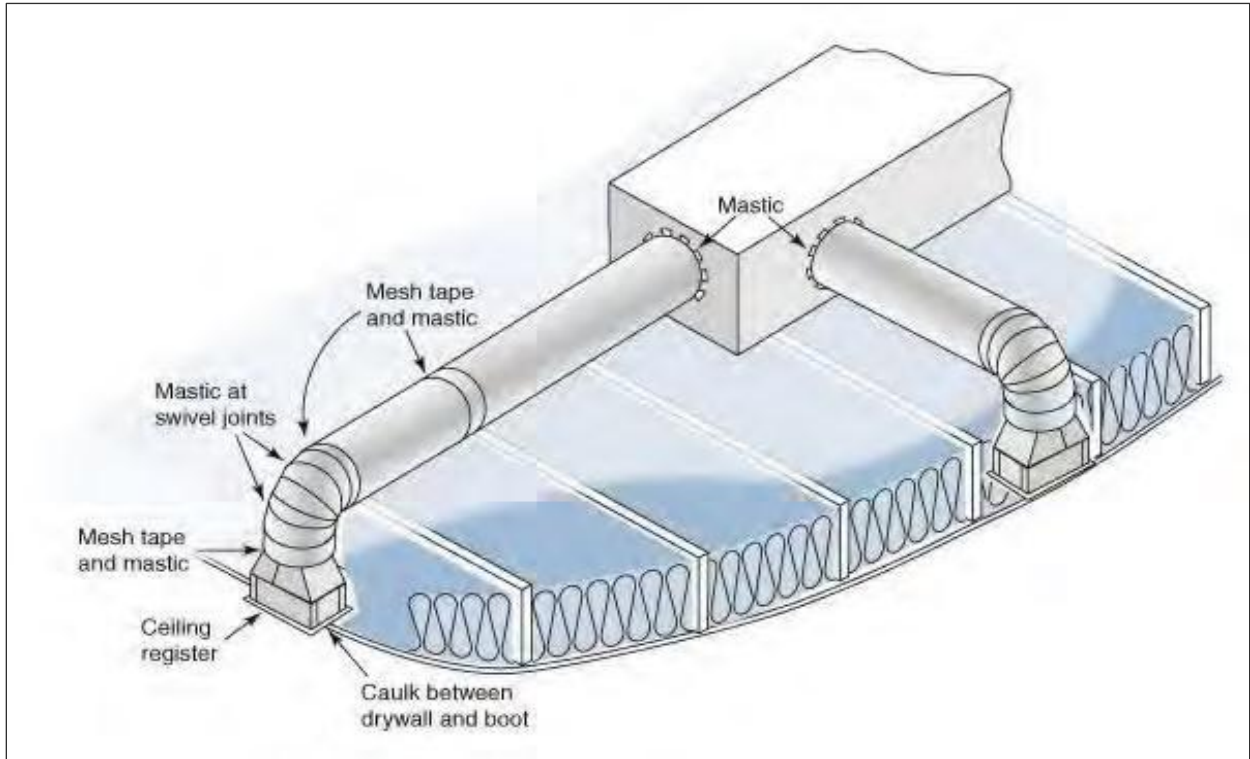

Duct Sealing Locations at Trunk and Branches

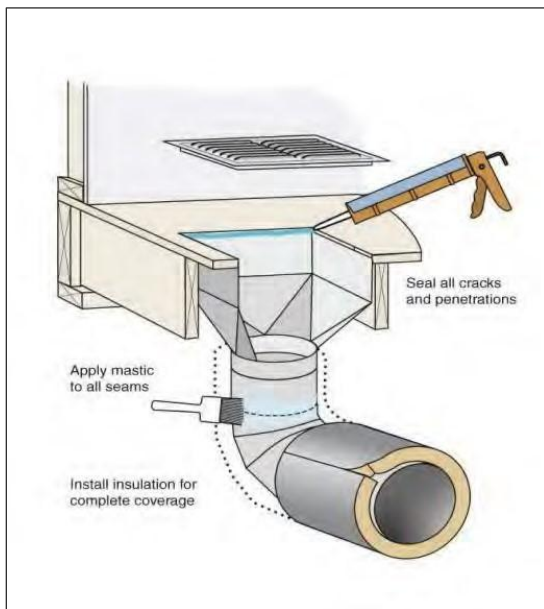

Duct Sealing Locations at Branch and Boot

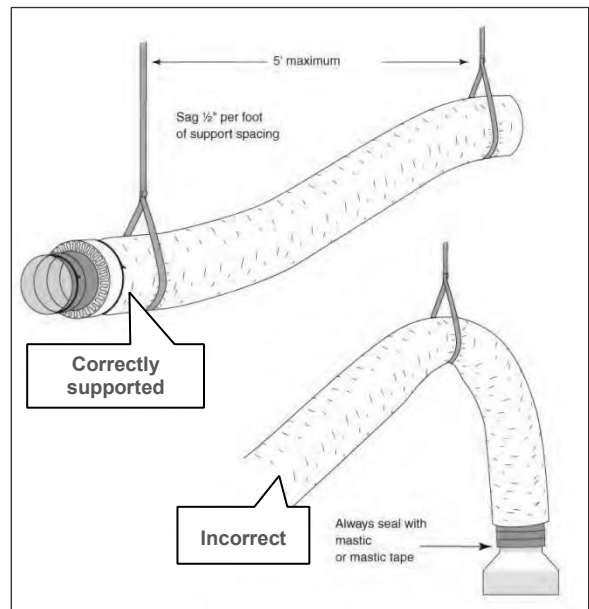

Flex Duct Support

Verification

- Construction Documents include duct design and all additional criteria for ductwork

ES R6: Existing Duct System Leakage Test

Purpose

Ensure ductwork located outside of conditioned space meets air tightness requirements.

Criteria

For projects that include any HVAC ductwork located outside of the building thermal envelope, the ductwork is subject to meeting minimum air tightness performance. A duct leakage test will be performed on the Final Site Visit to determine the amount of duct leakage occurring outside of the building’s thermal envelope.

- A. Total leakage $\leq 10\%$ and achieve $\geq 20\%$ improvement in tightness
- B. Leakage to Outside $\leq 6\%$ and achieve $\geq 20\%$ improvement in tightness

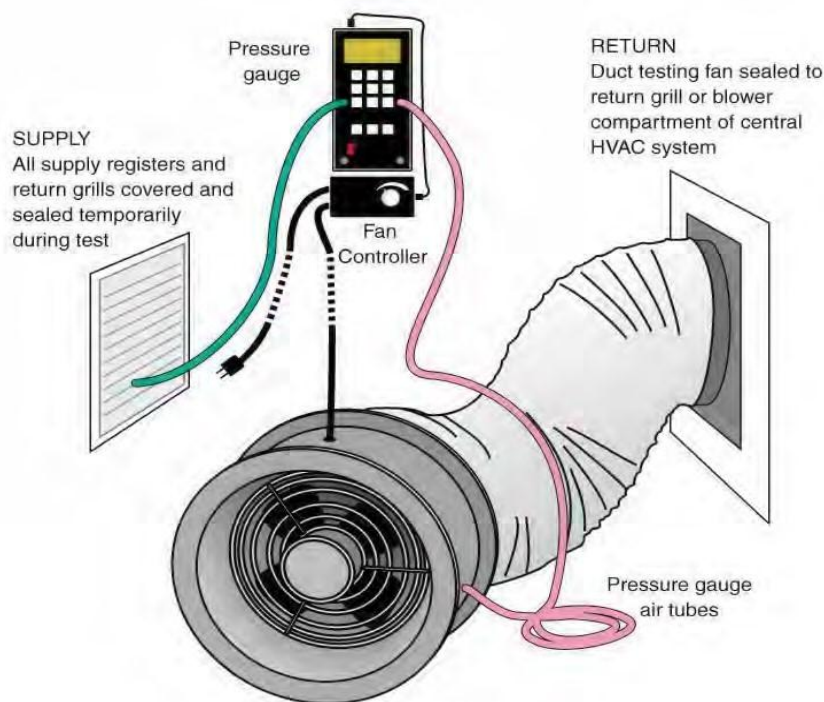

TESTING DUCT LEAKAGE TO OUTSIDE

HVAC systems and combustion appliances will be turned off and the building will be pressurized to +25 Pa with reference to the outdoors using blower door fan equipment.

- 1) *All supplies and returns will be temporarily sealed.*
- 2) *The duct system will be pressurized to +25 Pa with reference to outside using duct blower fan equipment (0.0 Pa with reference to the building).*

Test results will indicate the percent duct leakage occurring from the duct system to unconditioned space (i.e. outside of the building thermal envelope).

Definitions

Post-Construction Leakage to Outside (PCO)

The PCO is the amount (CFM) of air lost from the duct system into unconditioned spaces, expressed as a percentage of the total square footage of the zone served by that system. The duct leakage shall be determined when pressurized to +25 Pa (0.1" of water column).

CFM₂₅ (Cubic Feet per Minute at 25 Pa)

The volume flow rate of air in cubic feet per minute moved through a duct when pressurized to 25 Pa.

Zone CFA

Zone Conditioned Floor Area is the total floor area served by each individual HVAC duct system.

Pascal

A Pascal (Pa) is a small metric unit of pressure that is commonly used in lieu of inches of water column (1" water column = 248 Pa).

Verification

- Duct Leakage Test performed by Project Manager on Final Site Visit

ES R7: New Duct System Leakage Test

Purpose

Ensure ductwork located outside of conditioned space meets air tightness requirements.

Criteria

For projects that include any HVAC ductwork located outside of the building thermal envelope, the ductwork is subject to meeting minimum air tightness performance. A duct leakage test will be performed on the Final Site Visit to determine the amount of duct leakage occurring outside of the building’s thermal envelope.

- A. Total Leakage ≤4%**
- B. Leakage to Outside ≤3%**

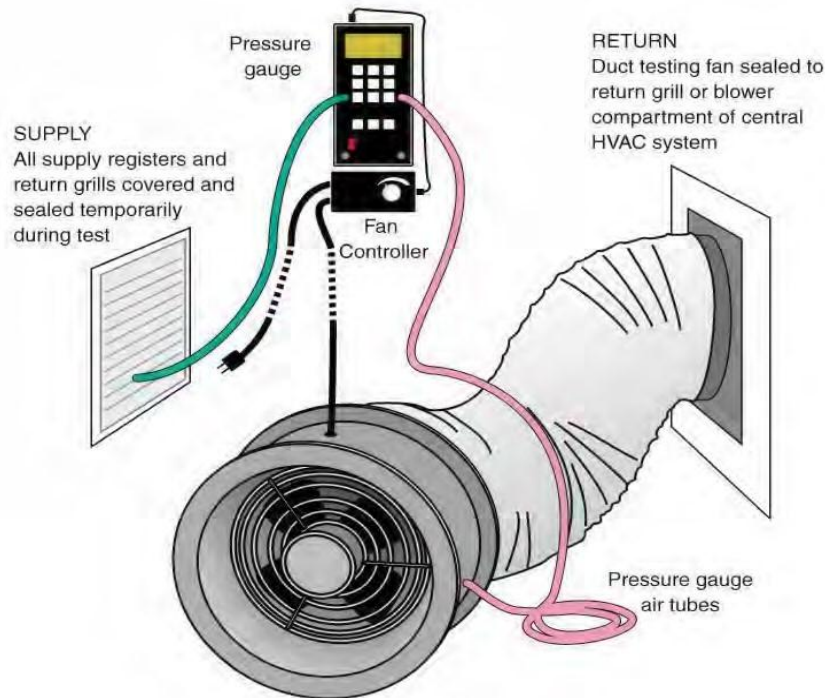

TESTING DUCT LEAKAGE TO OUTSIDE

HVAC systems and combustion appliances will be turned off and the building will be pressurized to +25 Pa with reference to the outdoors using blower door fan equipment.

- 1) All supplies and returns will be temporarily sealed.*
- 2) The duct system will be pressurized to +25 Pa with reference to outside using duct blower fan equipment (0.0 Pa with reference to the building).*

Test results will indicate the percent duct leakage occurring from the duct system to unconditioned space (i.e. outside of the building thermal envelope).

Definitions

Post-Construction Leakage to Outside (PCO)

The PCO is the amount (CFM) of air lost from the duct system into unconditioned spaces, expressed as a percentage of the total square footage of the zone served by that system. The duct leakage shall be determined when pressurized to +25 Pa (0.1" of water column).

CFM₂₅ (Cubic Feet per Minute at 25 Pa)

The volume flow rate of air in cubic feet per minute moved through a duct when pressurized to 25 Pa.

Zone CFA

Zone Conditioned Floor Area is the total floor area served by each individual HVAC duct system.

Pascal

A Pascal (Pa) is a small metric unit of pressure that is commonly used in lieu of inches of water column (1" water column = 248 Pa).

Verification

- Duct Leakage Test performed by Project Manager on Final Site Visit

ES R8: Minimum Efficiencies for New Water Heater

Purpose

Meet minimum efficiencies for new water heaters.

Criteria

In addition to meeting ASHRAE 90.1-2019, installed water heaters must meet the following minimum Energy Factors (EF's):

- Electric water heaters: 0.94 UEF or better
- Natural gas or propane water heaters: 0.64 UEF or better

Verification

- Plumbing Submittals
- Inspection by Project Manager

ES 1: Right-sized New Heating and Cooling Equipment

2 points**Purpose**

Optimize system performance to maintain desired indoor temperature and humidity conditions.

Criteria

Installed system cooling capacity is sized within 95% to 115% of calculated load. Refer to [ES R2: Provide Heating and Cooling Load Calculations](#) for details regarding Load Calculation requirements.

Verification

- Mechanical Submittals
- Inspection by Project Manager

ES R9: 100% of lighting is LED bulbs

Purpose

Provide efficient lighting in all permanently installed fixtures both indoors and outdoors

Criteria

- Specify and install LED lighting for indoor and outdoor lighting fixtures that are permanently installed

Verification

- Electrical Submittals
- Inspection by Project Manager

ES 2: Increased Cooling Equipment Efficiency**3-6 points**

Purpose

Encourage increased energy efficiency through cooling equipment selection.

Criteria:

Exceed ASHRAE Standard 90.1-2007 minimum efficiency requirements for 80% of installed cooling capacity.

Select one option below:

- A. 2 SEER or 1 EER Better Than Code (3 points)**
- B. 3 SEER or 2 EER Better Than Code (4 points)**
- C. 4 SEER or 3 EER Better Than Code (6 points)**

Note: For systems with IEER or IPLV ratings, check with ECLC Project Manager for efficiency conversion equivalencies.

Resources

American Society of Heating, Refrigerating and Air-Conditioning Engineers (ASHRAE) www.ashrae.org

Verification

- Mechanical Submittals
- Inspection by Project Manager

ES 3: Increased Heating Equipment Efficiency**3 points**

ES R10: When provided, appliances are ENERGY STAR rated

Purpose

Provide efficient appliances in residences and commercial spaces

Criteria

- If provided, the following appliances shall be ENERGY STAR certified:
- Refrigerators
- Dishwashers
- Clothes washer and dryer

Verification

- Electrical Submittals
- Project Manager will verify at final inspections

ES 1: Commercial: Increased Cooling Equipment Efficiency 2-4 Points**Purpose**

Encourage increased energy efficiency through cooling system selection

Criteria

Exceed ASHRAE Standard 90.1-2019 minimum efficiency requirements for 80% of installed heating capacity.

- A. ½ SEER2 or ½ EER2 Better (2 points)
- B. 1 SEER2 or 1 EER2 better (3 points)
- C. ≥2 SEER2 or ≥EER2 better (4 points)

Resources

American Society of Heating, Refrigerating and Air-Conditioning Engineers (ASHRAE) www.ashrae.org

Verification

- Mechanical Submittals
- Inspection by Project Manager

ES 2: Residential: Increased HVAC Equipment Efficiency**10 points**

Purpose

Encourage increased energy efficiency through HVAC system selection

Criteria

- ENERGY STAR Furnace >95% AFUE and within 40% of load calculations
- Heat pumps in CZ 2/3/4 ≥ 9 HSPF/ ≥ 7.65 HSPF2 and within 20% of load calculation
- Cooling equipment ≥ 16 SEER/15.2 SEER2. Meet selection requirements of Manual S based on equipment type selected

Use ductless systems for 80% of installed heating and cooling capacity. Ductless systems can potentially contribute towards the following point items:

ES 2: Increased Cooling Equipment Efficiency

ES 3: Increased Heating Equipment Efficiency

ES 6: High Efficiency Air Handler (ECM/VFD)

ES 7: All Air Handlers Located within Thermal Envelope

Note: Outside air must be delivered to each zone, per IAQ R2: Building Supply Ventilation Requirements.

Verification

- Mechanical Submittals
- Inspection by Project Manager

ES 3: Ductless Systems

5 points**Purpose**

Eliminate energy loss through duct leakage.

Criteria

Use ductless systems for 80% of installed heating and cooling capacity. Ductless systems can potentially contribute towards the following point items:

ES 2: Increased Cooling Equipment Efficiency

ES 3: Increased Heating Equipment Efficiency

ES 6: High Efficiency Air Handler (ECM/VFD)

ES 7: All Air Handlers Located within Thermal Envelope

Note: Outside air must be delivered to each zone, per IAQ R2: Building Supply Ventilation Requirements.

Verification

- Mechanical Submittals
- Inspection by Project Manager

ES 4: Multi-stage Compressor Cooling Equipment

3 points**Purpose**

Improve humidity control and provide greater efficiency at part load conditions

Criteria

Use multi-stage compressor cooling equipment for 100% of new cooling equipment. Low stage must be less than 75% of peak capacity as determined by Load Calculations. Refer to [ES R2: Provide Heating and Cooling Load Calculations](#) for details regarding Load Calculation requirements.

Verification

- Mechanical Submittals
- Inspection by Project Manager

ES 5: High Efficiency Air Handler

3 points**Purpose**

Increase system efficiency by regulating fan speed based on demand.

Criteria

Use Variable Frequency Drives (VFD's) or Electronically Commutated Motors (ECM's) for 100% of new air handlers.

Verification

- Mechanical Submittals
- Inspection by Project Manager

ES 6: All Air Handlers within Building Thermal Envelope

5 points**Purpose**

Eliminate air leakage to unconditioned space and reduce thermal losses and gains.

Criteria

All air handling units are located within the building thermal envelope.

Verification

- Inspection by Project Manager

ES 7: All Ductwork within Building Thermal Envelope

10 points**Purpose**

Eliminate air leakage to unconditioned space and reduce thermal losses and gains.

Criteria

Locate all ductwork within the building thermal envelope.

Exception: For package units, it is acceptable to run a sealed, maximum 4-foot straight duct from the unit to inside the building thermal envelope (refer to [ES R5: New Duct System Requirements](#)).

Note: Projects are not required to meet duct leakage testing requirements per [ES R4: Existing Duct Leakage Test](#) or [ES R6 New Duct Leakage Test](#) if all ductwork is located within the building thermal envelope.

Verification

- Inspection by Project Manager

ES 8: New Duct Work Distribution Efficiency**3 points**

Purpose

Reduce fan energy loss associated with pressure drops in overall duct distribution.

Criteria

Create a duct distribution design that supports efficient airflow patterns and minimizes pressure drops. Installed ductwork must meet the following criteria:

- Provide at least 2 feet of straight supply trunk between the fan discharge and the first turn
- Branch take-offs from supply trunk must begin at least 2 feet away from fan discharge
- Branch take-offs on same side of supply trunk must be spaced at least 6 inches apart
- Use radius elbows or turning vanes on square/rectangular ducts for turns greater than 45 degrees
- Use smooth wye branch fittings rather than right angle fittings for supply take-offs and transitions
- Size return duct cross sectional area to be at least 10% larger than supply ducts for each HVAC system

Verification

- Construction Documents include Duct Design Documentation (refer to [ES R6: New Duct System Requirements](#)) and detail duct distribution efficiency criteria
- Calculations: return-to-supply duct ratio per system
- Inspection by Project Manager

ES 9: Increased Interior Lighting Efficiency

3-6 points**Purpose**

Reduce energy consumption through efficient lighting design.

Criteria

Interior Lighting Power Density (LPD) is less than the maximum allowed per ASHRAE Standard 90.12007. Lighting efficiency improvement is demonstrated through COMcheck, and installed lighting must be consistent with COMcheck values.

Select one option below:

- A. LPD = 10% or better** (3 points)
- B. LPD = 20% or better** (4 points)
- C. LPD = 30% or better** (6 points)

Resources

American Society of Heating, Refrigerating and Air-Conditioning Engineers (ASHRAE) www.ashrae.org

COMcheck Software
www.energycodes.gov

Verification

- Construction Documents include Interior Lighting Schedule consistent with COMcheck and detail fixture types, lamp wattages, lamps per fixture, fixture wattages, and number of fixtures
- COMcheck File and a signed/completed COMcheck Interior Lighting and Power Compliance Certificate – submitted prior to start of construction
- Inspection by Project Manager

ES 10: Multi-level Lighting Controls for Occupants

2 points**Purpose**

Provide controls to reduce lighting load when natural light is available.

Criteria

Provide multi-level switching controls or dimmable lighting for all of the following spaces:

- Open offices
- Private offices
- Multi-purpose rooms (including all classrooms and training rooms)
- Conference rooms and meeting spaces

Verification

- Construction Documents indicate type and location of controls
- Inspection by an Project Manager

ES 11: Vacancy/Occupancy Sensors**5-10 points**

Purpose

Reduce energy consumption by automatically turning off lights when a room is vacant.

Criteria

Provide accessible vacancy or occupancy sensors for 75% (by room) of continuously occupied spaces and/or intermittently occupied spaces. Select one or more of the options below:

A. For 75% of Continuously Occupied Spaces (5 points)

- Open offices
- Private offices
- All classrooms (includes shop, lab and pre-K through 12)
- Reception area/lobby

B. For 75% of Intermittently Occupied Spaces (5 points)

- Restrooms
- Corridors
- Storage
- Mechanical rooms

Definitions

Continuously Occupied Spaces - spaces that are typically in use for 4 hours or more a day on a regular basis.

Intermittently Occupied Spaces - spaces that are typically accessed at irregular intervals throughout the day.

Verification

- Construction Documents indicate vacancy/occupancy sensor specifications and locations ▪

Inspection by Project Manager

ES 12: High Efficiency Water Heaters

2 points**Purpose**

Promote energy saving through the use of high efficiency water heaters.

Criteria

Meet the following minimum Energy Factor (EF's) for all installed water heaters:

- Condensing gas water heaters: 0.68 UEF or better
- Tankless gas water heaters: 0.87 UEF or better
- Heat pump water heaters: 3.00 UEF or better

If gas water heaters are installed they shall be sealed combustion, direct vent and/or completely separated from conditioned space/living space.

Verification

- Plumbing Submittals
- Inspection by Project Manager

ES 13: On-demand Hot Water Recirculation System**2 points**

Purpose

Conserve water and energy in water heating systems.

Criteria

Install an on-demand hot water recirculation pump at or past the furthest fixture (continuous circulation not allowed). Each fixture on the hot water line shall have automatic or manual controls tied to the on-demand pump.

Verification

- Construction Documents indicate type and location of on-demand hot water recirculation pump(s)
- Inspection by Project Manager

ES 14: ENERGY STAR Labeled Appliances and Equipment**2-8 points****Purpose**

Provide additional energy reduction during operations by installing ENERGY STAR Labeled products.

Criteria

Specify and install ENERGY STAR Labeled products for kitchen, laundry and office equipment.

Select one or more of the options below:

A. 100% of Residential and Commercial Appliances (2 points)

- Residential clothes washers
- Residential dishwashers
- Residential freezers
- Residential refrigerators
- Commercial clothes washers
- Vending machines
- Water coolers

B. 80% of Computers and Electronics (2 points)

- Enterprise servers
- Imaging equipment (copiers, scanners, etc.)
- Displays
- Audio/video equipment
- Battery chargers
- Computers
- Televisions

C. 80% of Commercial Food Service Equipment and Commercial Appliances (4 points)

- Commercial dishwashers
- Commercial fryers
- Commercial griddles
- Commercial hot food holding cabinets
- Commercial ice machines
- Commercial ovens
- Commercial refrigerators and freezers
- Commercial steam cookers

Resources

ENERGY STAR Labeled Products www.energystar.gov

Verification

- Manufacture specifications for equipment that does not have visible ENERGY STAR Label validation on appliance
- Inspection by Project Manager

ES 15: Solar Thermal Water Heating

5 points**Purpose**

Provide water heating with renewable energy resources.

Criteria

Install solar thermal collector as primary heating source for water.

Resources

Florida Solar Energy Center (FSEC) www.fsec.ucf.edu

Verification

- Inspection by Project Manager

ES 16: On-site Renewable Power Generation

5 – 25 points**Purpose**

Offset building energy use with renewable power generation.

Criteria

Install renewable power source(s) such as solar or wind on the project site for the purpose of offsetting building energy use. Points are awarded based on the amount of kilowatts installed.

Select number of points based on the following options:

A. 1 kW Generation (5 points)**B. Each Additional 1 kW Installation (up to 20 points)**

In addition to 5 points for meeting option A, up to 20 points will be awarded for each additional 1 kW.

Resources

Florida Solar Energy Center (FSEC) www.fsec.ucf.edu

Verification

- Construction Documents indicate type, location and total power generation of on-site renewable energy source(s)
- Inspection by ECLC Project Manager

ES 18: Interior Lighting Controls

5 - 10 points**Purpose**

Provide controls to reduce energy use by reducing internal lighting loads.

Criteria

Installed interior lighting controls provided in the following spaces.

- **Vacancy Sensors – 5 points**
 - Private offices
 - Storage / Mechanical rooms
 - Classrooms (not including shop classrooms, laboratory classrooms and preschool through 12th grade classrooms)
 - Conference rooms and meeting spaces
 - Employee lunch rooms and break rooms
- **Photocell / Light Sensors 5 points**
 - 75% of Daylight Area

Resources

American Society of Heating, Refrigerating and Air-Conditioning Engineers (ASHRAE) www.ashrae.org

Verification

- Construction Documents detail location of vacancy sensors (if applicable) and after hours shutoff controls
- Inspection by Project Manager

ES 17: Improve Energy Efficiency for Service Water Heating

5 points**Purpose**

Improve energy efficiency for water heating equipment.

Criteria

Comply with the following items for water heaters:

- Tank water heaters include heat traps
- Install insulation on first 2 feet of cold water pipes and first 8 feet of hot water pipes
- Insulation and timer controls required for recirculating hot water systems

Resources

American Society of Heating, Refrigerating and Air-Conditioning Engineers (ASHRAE) www.ashrae.org

COMcheck Software
www.energycodes.gov

Verification

- Plumbing Submittals
- COMcheck file and a signed/completed COMcheck Mechanical Compliance Certificate – submitted prior to start of construction
- Inspection by Project Manager

ES 18: Building Systems Retro-Commissioning

8 points**Purpose**

Ensure energy systems are installed and operating as designed.

Criteria

Engage a third-party Commissioning Agent to ensure that the project's energy-related systems perform as intended. The following should be included as part building systems retro-commissioning:

- HVAC and controls
- Lighting and daylighting controls
- Water heating systems
- Renewable energy systems

Verification

- Copy of Retro-Commissioning Report

Water Efficiency

WE R1: WaterSense Fixtures

Purpose

Conserve water through use of water-efficient fixtures.

Criteria

All new fixtures must meet minimum water efficiency criteria for water closets, urinals, lavatory faucets and shower heads.

The table below outlines maximum flow rates per fixture:

FIXTURE	MAXIMUM FLOW RATES
Standard Toilets	1.28 gpf
Dual Flush Toilets	1.1 gpf/1.28 gpf
Urinals	0.50 gpf
Lavatory Faucets	1.5 gpm or 0.25 gpc
Shower Heads	1.5 gpm

gpf = gallons per flush, gpm = gallons per minute, gpc = gallons per cycle

Definitions

Gallons Per Cycle (gpc) pertains to metered faucets and is a measure of the amount of water dispensed during each cycle.

Verification

- Plumbing Submittals include efficiencies for toilets, urinals, lavatory faucets and shower heads ▪
Inspection by Project Manager

WE R2: Shut-off Controls for Any Installed Irrigation System

Purpose

Encourage irrigation system efficiency by designing systems to minimize water waste.

Criteria

Any permanently installed irrigation system must include shut-off controls. Irrigation system must be timer controlled at a minimum and must be indicated on landscape plans.

Verification

- Landscape Plan includes location and type(s) of shut-off controls
- Inspection by Project Manager

WE 1: Pint Flush or Waterless Urinals

2-4 points**Purpose**

Reduce the amount of potable water used for sewage conveyance by installing efficient fixtures.

Criteria

Increase the efficiency of water use in the building design by specifying high efficiency urinals. To meet the criteria, ALL installed urinal fixtures must be pint flush (0.20 gpf) or less.

Select one option below:

- A. Pint Flush Urinals (2 points)**
- B. Waterless Urinals (4 points)**

Verification

- Plumbing Submittals
- Inspection by Project Manager

WE 2: Non-potable Water Source for Sewage Conveyance

6-12 points**Purpose**

Eliminate potable water used for sewage conveyance by utilizing other water resources.

Criteria

Design an appropriately sized alternative water collection system that meets the needs of water demand for sewage conveyance. It is highly recommended that this strategy be coupled with highly efficient fixtures to minimize water demand.

Select one option below:

C. 50% of Toilet/Urinal Fixtures (6 points) D.

100% of Toilet/Urinal Fixtures (12 points)

Qualifying water sources can be from a single source or a combination of rainwater, greywater, or condensate reuse. Methods for water collection must be indicated on Construction Drawings.

Note: Any installed rainwater, greywater or condensation collection system for indoor water use must comply with all applicable state and local laws.

Resources

U.S. Department of Energy, Best Management Practice: Alternate Water Sources www.eere.energy.gov

Verification

- Construction Documents include water collection methods and quantities
- Inspection by Project Manager

WE 3: Advanced Outdoor Water Efficiency Strategies**1-10 points**

Purpose

Reduce or eliminate potable water-use for irrigation.

Criteria

By designing and installing drought-tolerant, native or adaptive plant material, the need for water is greatly reduced, and can even be eliminated entirely.

Select one or more of the options below:

A. No Irrigation System Installed (3 points)**B. Non-potable Water Source Used for Irrigation (5 points)**

Use alternative water sources such as rainwater, greywater, or condensate for irrigation in lieu of potable water.

C. Irrigation System Design by WaterSense Professional (1 point)

Irrigation system designed, installed and audited by a WaterSense Landscape Irrigation Professional. The WaterSense Professional will ensure there are no leaks in the irrigation system, that they do not create runoff or overspray, that there is low quarter distribution uniformity and that there is a rainfall shut-off device.

D. Zoned Irrigation System (1 point)

Meet specific water needs for each planting area by isolating areas that require more or less water and by delivering water to each independently.

E. Drip Irrigation System (1 point) In lieu of spray irrigation system.**F. Weather Station or Soil Moisture Sensors (1 point)**

Irrigation systems shall be equipped with technology that inhibits or interrupts operation of the irrigation system during periods of rainfall or sufficient soil moisture.

G. Seasonal Water Schedules (1 point)

Post "grow-in phase" and "established" landscape seasonal water schedules at irrigation controller(s) for each watering zone.

Verification

- Construction Documents detail non-potable water source(s) and quantities
- Inspection by Project Manager

Education and Operations

EO R1: Provide Maintenance Schedule to Owner/Occupant

Purpose

Educate owner/occupant on routine equipment maintenance needed to ensure efficient building performance.

Criteria

In addition to close-out documents, provide a concise document that captures the routine maintenance schedule for energy systems and water heating equipment.

The Maintenance Schedule should, at minimum, include the following:

- **Equipment Maintenance Intervals**
 - Heating, cooling and ventilation
 - Water heating
- **Ventilation Filtration**
 - MERV rating
 - Size(s) of filtration media
 - Frequency of replacement
- **Special Systems Maintenance** (as applicable)
 - Non-potable water capture catchment (rainwater, condensate, or greywater collection)
 - Low water use fixtures (e.g. waterless urinals)

Also refer to [EO 1: Facility Operations Manual](#), where points can be awarded for a more comprehensive manual to maintain building systems efficiency.

Verification

- Provide copy of Maintenance Schedule to ECLC Project Manager and Owner

EO R2: Commercial: No Smoking Policy**Purpose**

Reduce exposure to environmental tobacco smoke (ETS) by removing pollutant source from occupant breathing zones.

Criteria

Provide a No Smoking Policy and locate all smoking areas outside and at least 25 feet away from operable doors, windows, and outside air intakes.

Verification

- Provide signed "No Smoking Policy" statement
- Construction Documents indicate location(s) of any outdoors smoking area

EO R3: Recycling Accommodations

Purpose

Encourage the procurement and reuse of recyclable products and materials.

Criteria

Designate areas with clearly marked receptacles for recycling aluminum, plastic, paper, glass, and cardboard. If the building has more than one floor, then there must be provisions for recycling on each floor.

Verification

- Construction Drawings indicate designated areas for recyclables collection
- Inspection by Project Manager

EO 1: Facility Operations Manual

2 points**Purpose**

Educate owner/occupant on building operation best practices to maximize performance.

Criteria

Supply owner/occupant with a concise document describing proper building maintenance and operation. Review document with Owner/Occupant prior to hand-off.

At minimum, the document should include:

- Measures on how to maintain water, energy and indoor air quality performance
- Photographs of construction, including pre-drywall photographs
- Landscape design and irrigation systems (such non-potable water sources)
- Equipment maintenance schedule from EO R2: Provide Maintenance Schedule to Owner/Occupant

Resources

Facilities Operation Manual Template www.earthcraft.org

Verification

- Provide a copy of Facility Operation's Manual to Project Manager

EO 2: Recycling Collection**2 points**

Purpose

Encourage a firm commitment to recycling.

Criteria

Project must have contract for recycling collection provided by either private or municipal recycling services. At a minimum, the collection should include plastic, paper, cardboard, glass, and aluminum materials.

Verification

- Provide copy of signed contract or evidence of municipal recycling program

EO 3: Educational Displays**2-4 points****Purpose**

Educate building occupants and visitors on environmentally responsible design and construction practices.

Criteria:

Provide educational displays on the building's sustainable design and construction features.

Select one or both options below:

A. Educational Signage and Displays (2 points)

Include environmental and efficiency measures, as well as information about EarthCraft certification.

B. Interactive Display (2 points)

Provide users with interactive, real-time data on the environmental features of the building.

Verification

- Inspection by Project Manager

Innovation

INNOVATION POINTS (IN)

5-15 points

Purpose

Reward project team for going above and beyond the measures outlines in the program.

Criteria

Up to 15 points are available (3 measures - valued at 5 points each) for projects that include sustainable strategies that go above and beyond those outlined in the program.

In order to be considered, the team must submit a narrative of the measures employed and provide supporting documentation in the form of specifications, calculations and/or photographs for verification purposes.

Below are examples for consideration (this list is not all inclusive):

- Energy Systems Measurement and Verification Plan
- Solar Renewable Energy or Geothermal Ready Provisions
- On-site Fuel Cell or Co-generation System
- Advanced Framing Strategies for Wood Framed Construction
- Design for Deconstruction: building is designed for disassembly/reassembly
- Salvage and Reclaimed Demo/Deconstruction Materials Used On-site: for example - ground sidewalks used as aggregate
- Excavated Trees Milled for Reuse Lumber (not shredded or mulched)
- Process Water Reduction
- Vegetated "Green" Roof
- Compost Toilet System (less than 0.1 gpf)
- Company Sustainability Policy: include guidelines and tracking process (consider carpooling, recycling, green purchasing, green cleaning, carbon offsets, employee incentives, etc)
- Alternative Fuel Company Vehicle (e.g. electric, bio-diesel, natural gas, LP, Prius or equivalent mileage)
- Telecommuting Provisions/ Employee Carpool Program/ Car Share Account
- Company Green Cleaning Policy
- Integrated Pest Management (IPM) Plan
- Composting Area for Landscaping Debris and/or Food Waste
- Edible Garden within Project Site Boundary

Verification

- Narrative of measure employed
- Supporting documentation: e.g. specifications, calculations, photographs

New Construction Requirements

New Construction Requirements Introduction

The requirements in this section are applicable only to new construction greater than 500 square feet associated with the project. They are not applicable to the renovation of historic buildings.

Based on high performance building best practices and the standards of the Earthcraft Light Commercial Program, these requirements are intended to guide project teams when creating new additions as part of the renovation of a historic structure.

Project team should always consult with preservation professionals, local guidelines, and preservation best practices when considering additions to historic buildings in order to ensure appropriate design.

NC R1: Gravel Bed Beneath Slab Foundations

Purpose

Reduce potential for ground source moisture entry into building.

Criteria

Install a minimum 4 inch deep gravel bed for drainage beneath slabs supported by soil.

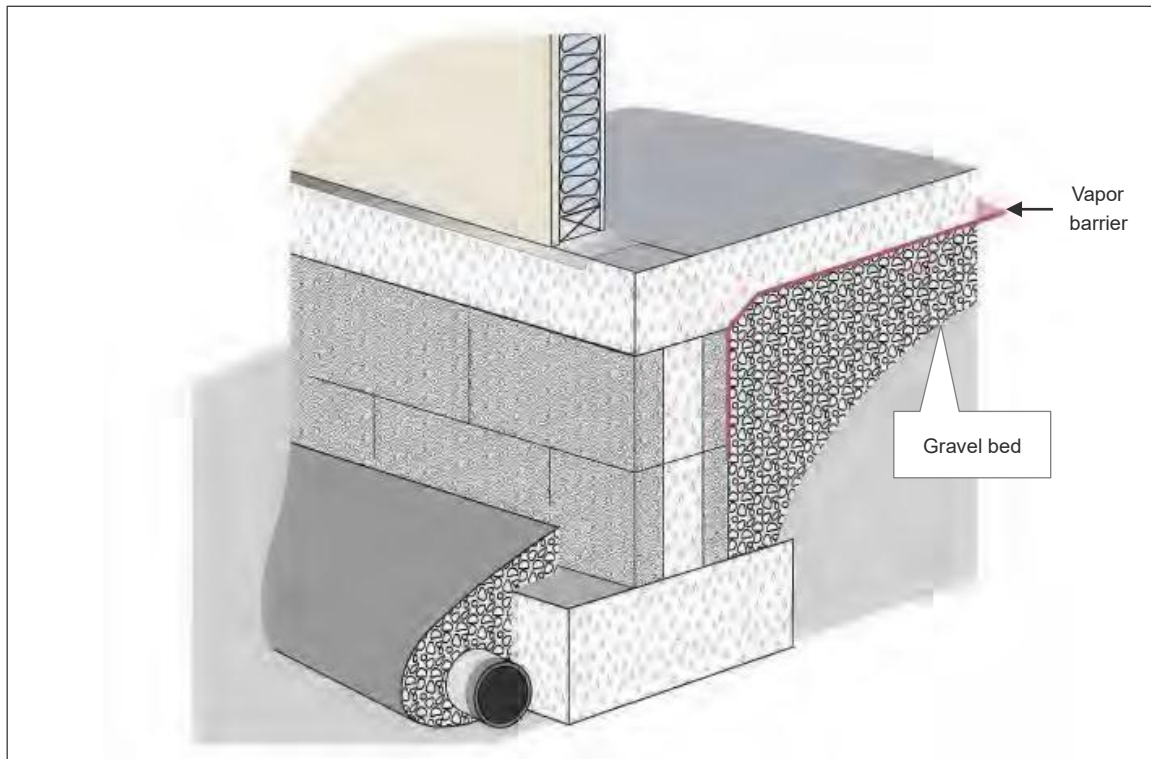

Gravel Bed Beneath Vapor Barrier

Note: In some coastal regions, an exception may be allowed for use of sand in lieu of gravel if approved by Project Manager prior to construction.

Verification

- Construction Documents indicate gravel bed detail
- Photos of installation provided to Project Manager

NC R2: Vapor Barrier Beneath Slab Foundations and in Crawlspace

Purpose

Reduce potential for ground source moisture entry into building.

Criteria

Install a Class I Vapor Retarder (minimum 6 mil thick polyethylene vapor barrier) beneath all slabs supported by soil and over all exposed earth in crawlspaces.

Construction Drawings must include details regarding the vapor barrier location and application:

Slab Installations

The vapor barrier must be installed between slab and gravel base.

Crawlspace Installations

Apply 100% coverage over crawlspace floor. Extend sheeting up foundation walls at least 12 inches above grade of exterior soil. All seams should be overlapped at least 12 inches, and sealed at seams and to walls with mastic or other equivalent sealant.

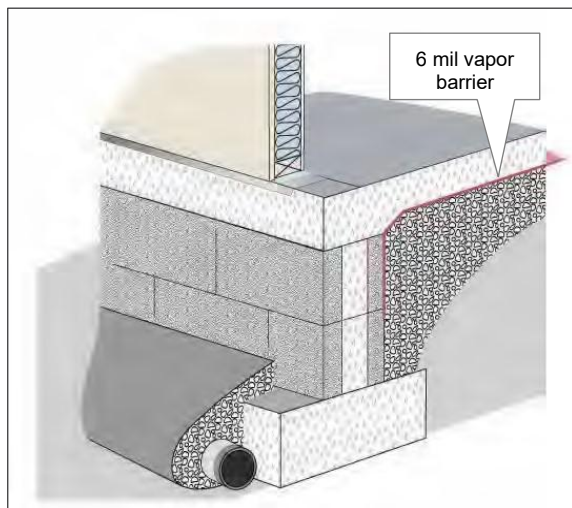

Vapor Barrier Installed Beneath Slab

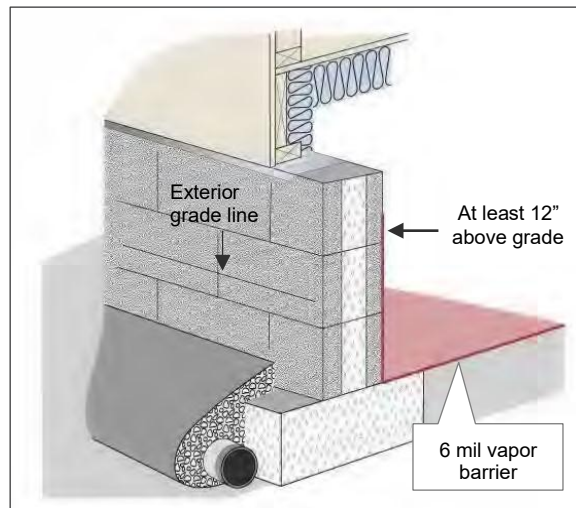

Vapor Barrier Installed in Crawlspace

Resources

2009 International Building Code (IBC), Section 1910 Minimum Slab Provisions www.iccsafe.org

Verification

- Construction Documents indicate vapor barrier detail
- Slabs: Photos of vapor barrier installation provided
- Crawlspaces: Inspection by Project Manager

NC R3: Roof Designed for Efficient Drainage

Purpose

Avoid bulk water intrusion and increase building envelope durability.

Criteria

Design the roofing system so that rainwater is directed away from the building walls and foundation. Include a complete gutter or roof drainage system to discharge 100% of roof water runoff at least 5 feet away from building foundation.

MR: Major renovation projects with existing site conditions that preclude the achievement of this requirement may pursue alternative compliance strategies with approval of the Project Manager.

Resources

2009 International Building Code (IBC), 1503.4 Roof Drainage www.iccsafe.org

Verification

- Construction Documents detailing full gutter and/or roof drainage discharge system ▪

Inspection by Project Manager

NC R4: Integrated Drainage Planes

Purpose

Reduce risk of bulk water intrusion at building envelope.

Criteria

Create an efficient drainage plane across the building envelope. Address roof and wall intersections, changes in wall cladding, door/window penetrations and all other penetrations. Indicate flashing details clearly on construction drawings and plan to take photographs of areas that may be covered prior to visit by Technical Advisor to demonstrate details have been executed properly.

The following must be addressed if applicable:

- Flashing or self-adhering underlayment at roof valleys and roof penetrations
- Flashing at roof-to-wall intersections
- Proper flashing and drainage plane transition details at changes in wall cladding
- Drainage plane is integrated with window and door head/jamb, and with pan flashing at door and window sills
- Building wrap or felt installed in "shingle-lap" fashion
 - High piece of wrap/felt is lapped over top of piece below
 - Horizontal overlaps are at least 4"
 - Vertical overlaps are at least 6"
 - All joints are sealed or taped
- Weather-resistive sheathing (e.g. XPS foam) fully taped at all "butt" joints



Flashing at Roof Valley

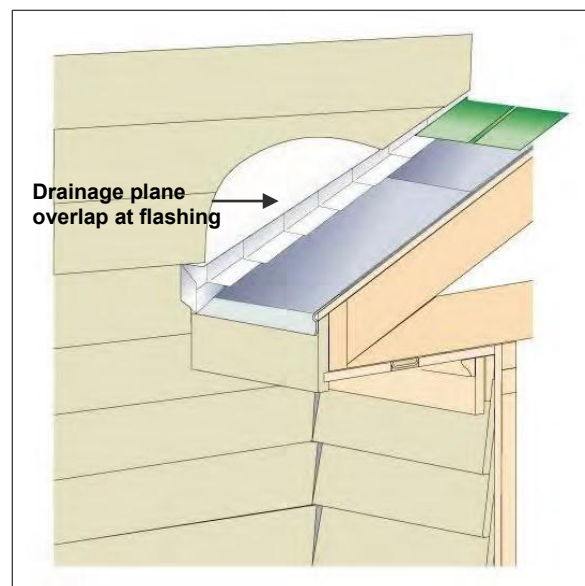

Flashing at Roof – to – Wall Intersection

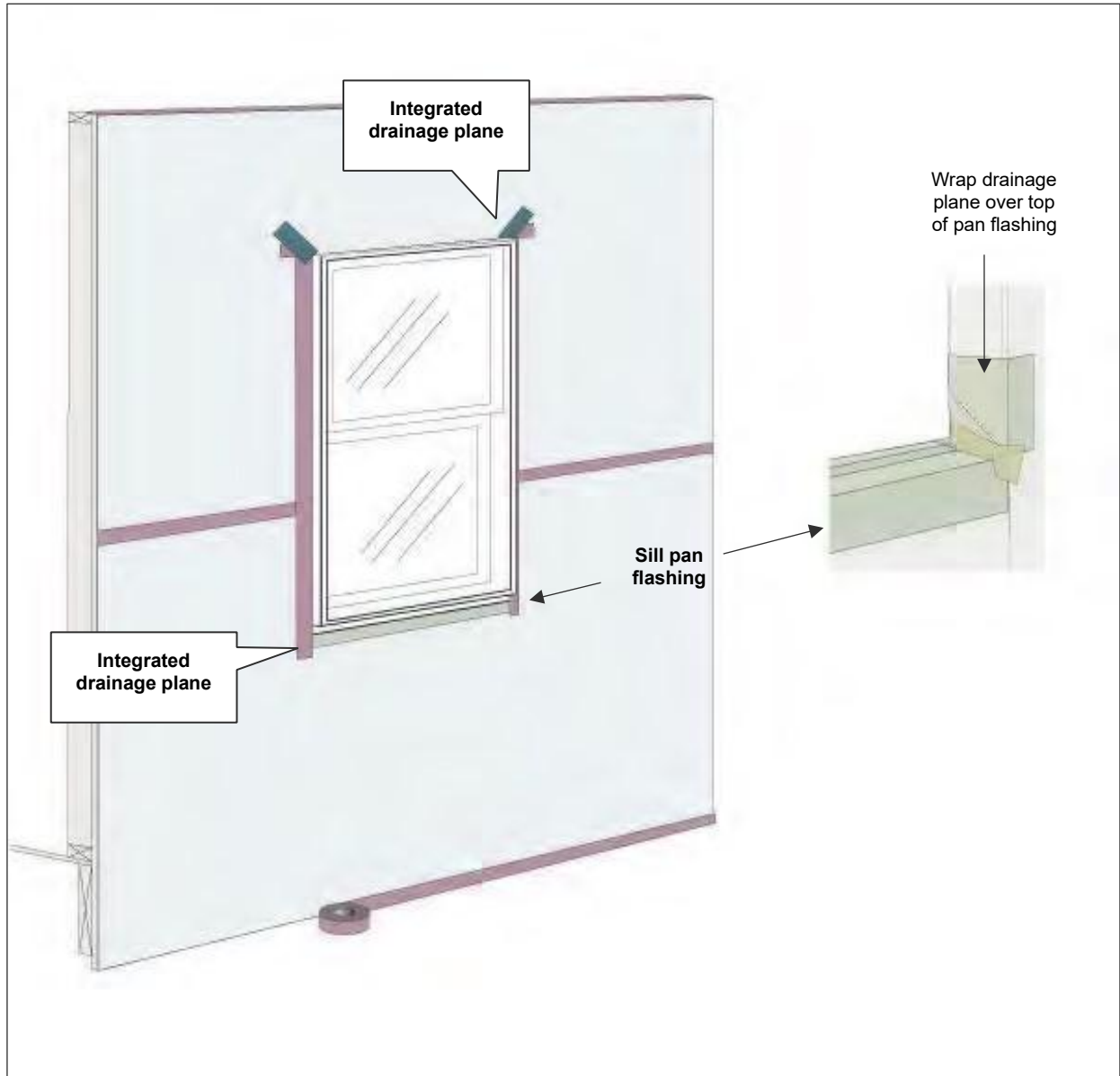

Integrated Flashing at Window Penetration

Resources

2009 International Building Code (IBC), Section 1405.4 Flashing, 1503.2 Flashing, 1503.3 Coping
www.iccsafe.org

Verification

- Construction Documents include integrated drainage plane details
- Inspection by Project Manager

NC R5: Positive Drainage at Grade

Purpose

Reduce potential for bulk water intrusion at building foundation.

Criteria

Provide positive drainage at finished grade for all sides of the building. Ground must be consistently sloped away from the building foundation at a minimum of one unit vertical in 20 units horizontal ($\geq 5\%$ slope), for a minimum distance of 10 feet measured perpendicular to the face of the wall. Where setbacks limit space to less than 10 feet, install swales or drains designed to carry water away from the foundation.

Resources

2009 International Building Code (IBC), Section 1804.3 Site Grading www.iccsafe.org

Verification

- Inspection by Project Manager

NC R6: Capillary Break at Foundation

Purpose

Provide additional waterproofing protection at building foundation/footing.

Criteria

Install a capillary break to reduce the potential for ground water to permeate up through the building footing and foundation.

Select one or both of the options below:

A. Between Foundation and Wood Framing in Contact with Slab

Install a capillary break between a concrete foundation wall/slab floor and wood sill plate using a complete framed wall width sill gasket, EPDM-type rubber, sheet metal or other suitable membrane to prevent moisture from wicking through the foundation into the framing. Capillary break should be installed between all foundations and wood sill plates, not just exterior walls. Only wood-framed projects are eligible for these points.

B. Between Footing and Slab/Foundation Wall - OR - Beneath Footing

Form a capillary break between the ground and the footing or between the footing and slab/foundation. The purpose of the capillary break is to prevent groundwater from wicking into the foundation and evaporating into conditioned space. The capillary break must have complete coverage and must not compromise mechanical connection between footing and foundation (e.g., hydraulic "masonry" water proofing product, foundation water-proofing material).

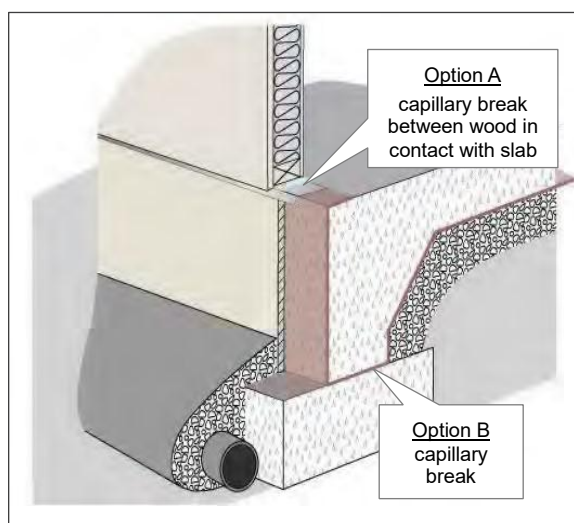

Capillary Break Between Footing and Slab

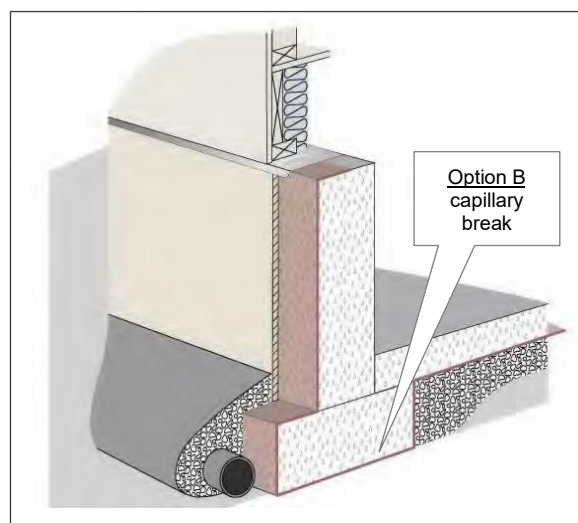

Capillary Break Beneath Footing

Verification

- Construction Documents indicate capillary break details
- Provide photos of capillary breaks installed prior to the 1st Site Visit that cannot visually verified

- Inspection by Project Manager

NC R7: Drainage Plane for Below-Grade Walls

Purpose

Avoid bulk water intrusion and mold issues typically associated with below-grade wall areas.

Criteria

Manage water efficiently at below-grade walls by creating a two-part system comprised of waterproofing (dampproofing does not meet criteria) and a drainage board/mat that channels water down and away from the foundation. Waterproofing shall be applied from the bottom of the wall to at least 12 inches above the maximum elevation of the groundwater table.

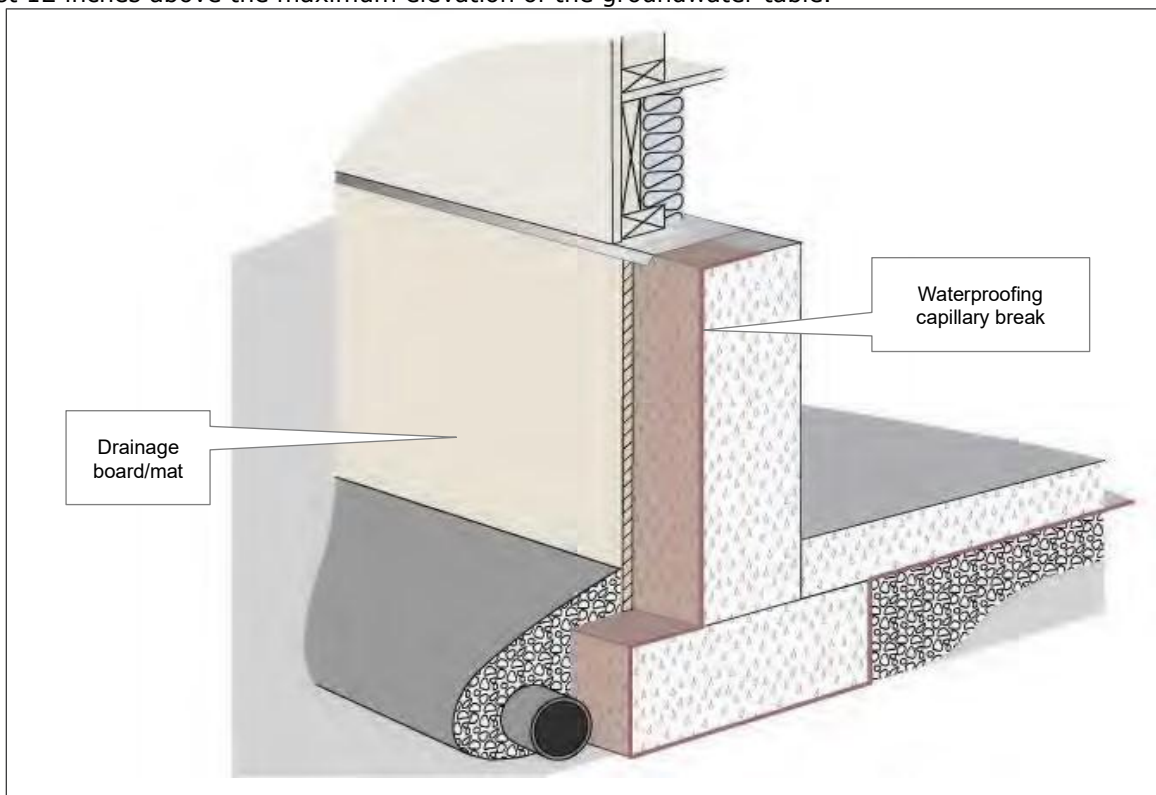

Drainage Plane Applied At Below Grade Wall

Resources

2009 International Building Code (IBC), Section 1805.3 Waterproofing www.iccsafe.org

Verification

- Construction Documents detail drainage board/mat and waterproofing
- Provide photos of installation

NC R8: Foundation Drainage

Purpose

Avoid bulk water intrusion at the base of the building foundation.

Criteria

Efficiently manage water away from building foundation by installing a protected foundation drain. Install the drain so that the top of the perforated drain pipe is below the bottom edge of the concrete slab or crawlspace floor, or alongside the outside perimeter edge of the footing, whichever is lower.

A fabric drain sleeve should be installed on the perforated drain pipe and each drain pipe should be surrounded by a layer of 1/2" to 3/4" gravel (minimum 6 inches on top and sides and minimum 2 inches on bottom). Gravel layer shall extend at least 1 foot beyond the outside edge of the footing and 6 inches above the top of the footing and shall be covered with filter fabric. Foundation drainage shall discharge by gravity or mechanical means into an approved drainage system (per local code requirements).

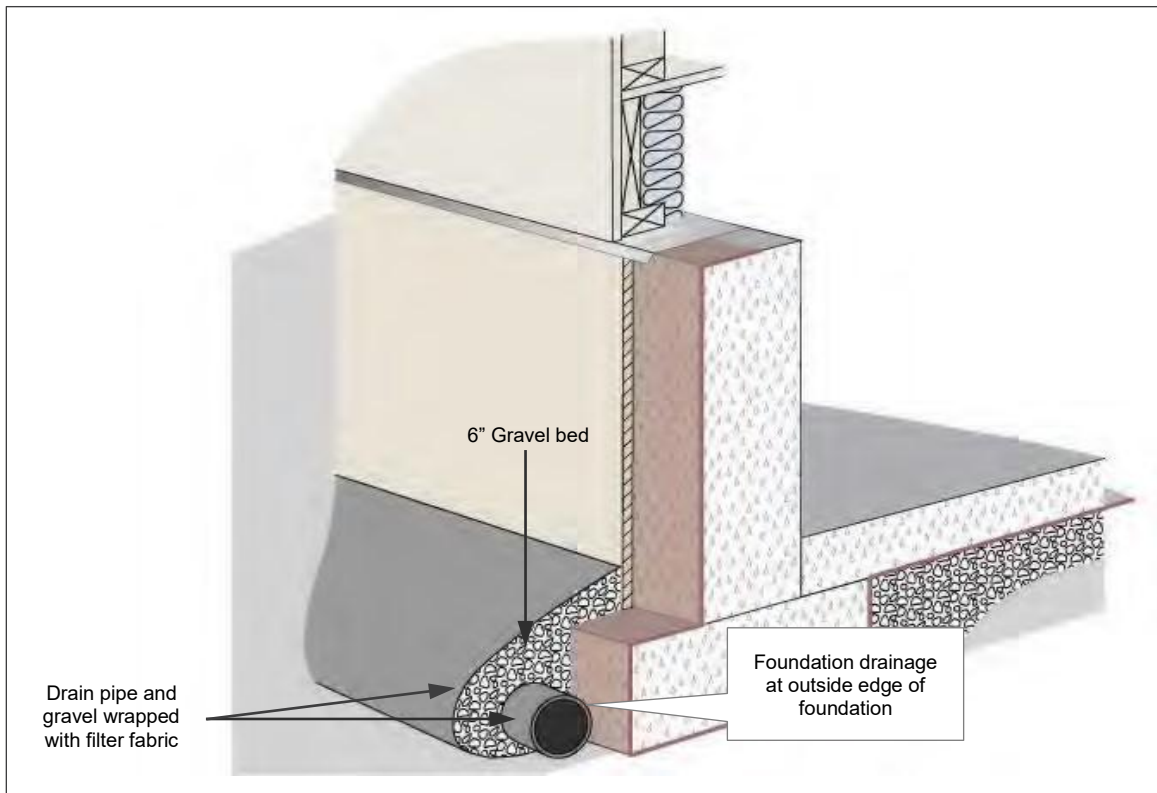

Foundation Drainage System Outside Perimeter Edge of Crawlspace Wall Footing

Resources

2009 International Building Code (IBC), Section 1805.4 Subsoil Drainage System www.iccsafe.org

Verification

- Construction Documents indicate location(s) of foundation drainage
- Photos of installation

NC R9: Continuous Foundation Termite Shield**Purpose**

Prevent structural damage due to termite infestation.

Criteria

In the Southeast, it is particularly important that foundation areas prone to termite infestation be addressed. Install a continuous termite shield that provides a turndown break between the framing and foundation stem wall, piers, slab perimeter, and other potential entry points. The termite shield can be fabricated from metal or similar flashing material that forms a physical barrier to termites.

All seams and penetrations in the termite shield must be effectively sealed to prevent termite entry and to maintain air tightness of building envelope.

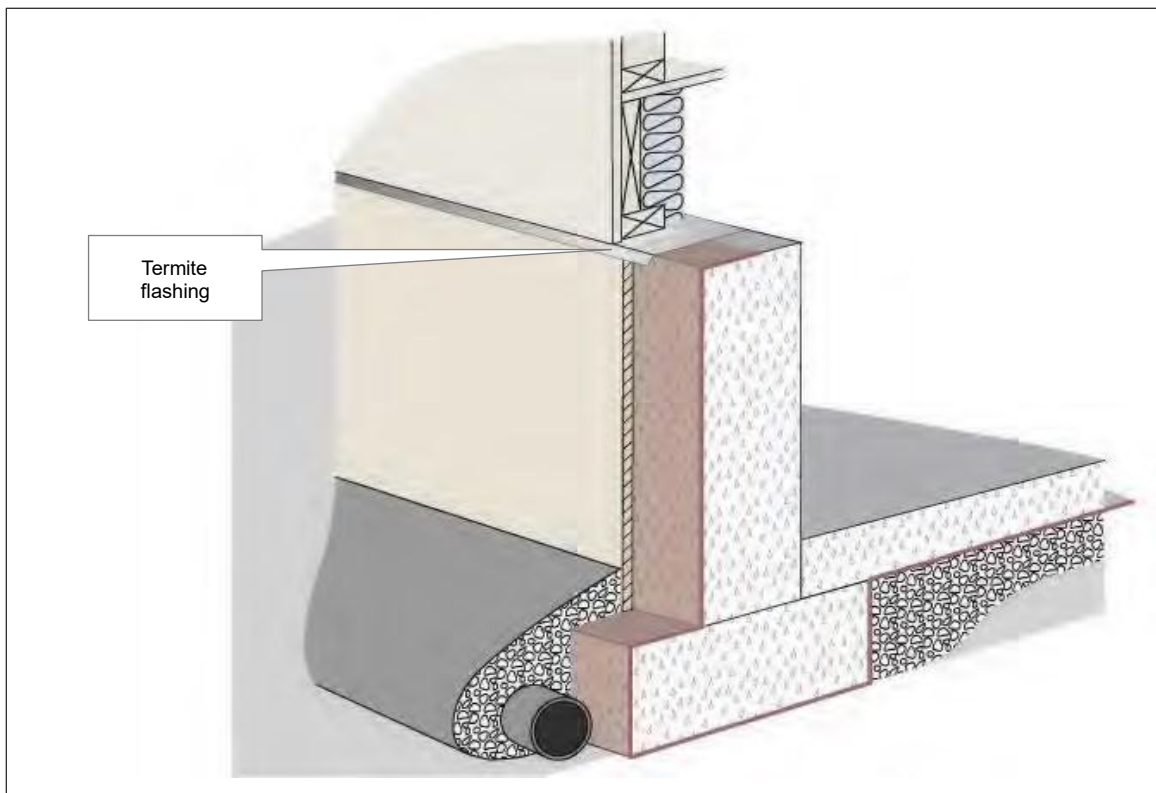

Termite Shield Between Wood Framing and Foundation Stem Wall

Verification

- Provide photos of termite shield installation if cannot be visually verified on site visit ▪

Inspection by Project Manager

NC R10: Durable Roof System**Purpose**

Utilize durable roofing materials and applications.

Criteria

Select roofing systems with proven durability. Installed roofing must consist of one or a combination of the following products and/or applications:

- Roofing product with life expectancy of 40+ years (e.g. concrete tile, copper, slate, etc.)
- Inverted Roof Membrane Assembly (IRMA)
- Roof with NDL (No Dollar Limit) Warranty of 15 years or longer

-AND-

Any roof area housing mechanical equipment or other systems requiring ongoing maintenance must have walk pads leading to and around those systems.

Verification

- Construction Documents detail roofing specifications and/or warranty information, as applicable ▪

Inspection by Project Manager

NC R11: Vented Rain Screen

Purpose

Reduce potential for water intrusion through exterior wall assemblies.

Criteria

Create a vented rain screen behind the building facade. A vented rain screen is simply an air space between the structure and the facade that provides a means for intruding water to escape by draining down and away from the building assembly within that air gap.

To achieve proper drainage, meet the following criteria:

Cladding

Install furring strips to maintain a minimum of 3/8" gap or an engineered rain screen product that provides an air space between the exterior cladding and weather-resistant air barrier. The system must be integrated with flashing and be designed and installed to minimize moisture migration between the exterior cladding and the wall sheathing. The system only needs to be open at the bottom. Consider installing an insect barrier at vent locations.

Masonry Veneer

Provide a 1" air gap behind the masonry and full-head weep holes with a minimum 24" on center spacing at bottom of wall assembly.

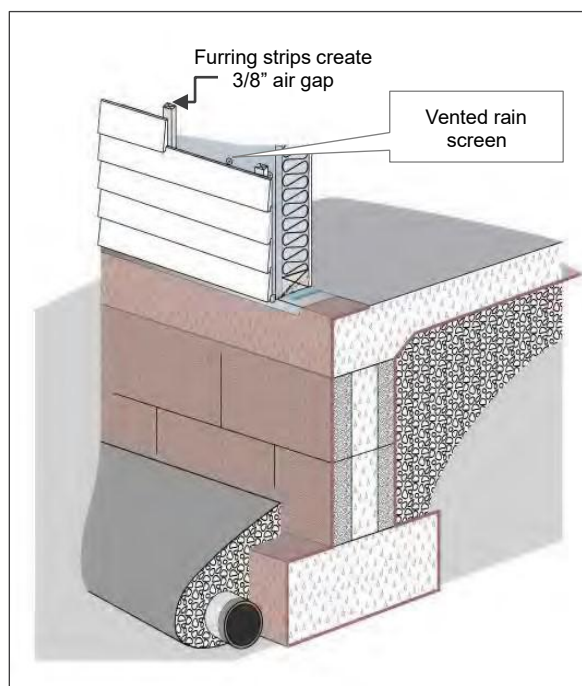

Vented Rain Screen - Cladding

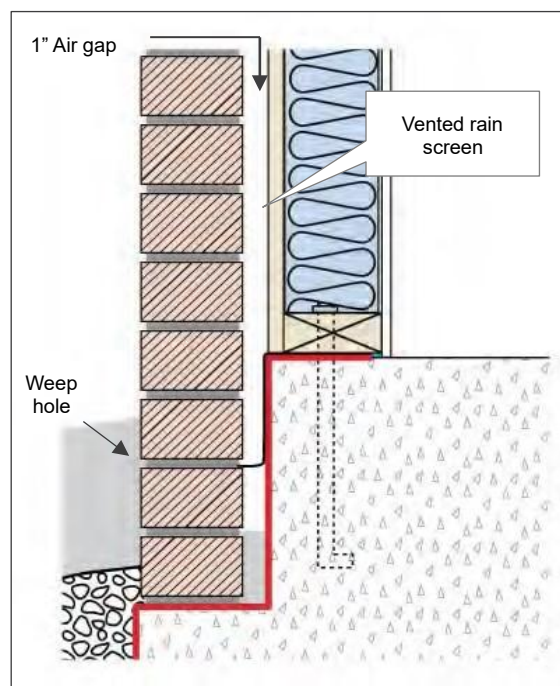

Vented Rain Screen – Masonry Veneer

Verification

- Construction Documents indicate depth of air gap for vented rain screen
- Inspection by Project Manager

NC R12: Back-primed Siding and Trim**Purpose**

Improve long-term weather resistance of wood, fiber-cement and cellulose-based materials.

Criteria

For wood and cellulose-based products, prime all six sides of painted or solid-stained exterior siding and trim prior to installation. Back-priming is required for semi-transparent and transparent stained exterior siding and trim, however it is acceptable to stain the remaining five sides.

Verification

- Provide photos of back-priming if cannot be visually verified during site visit
- Inspection by Project Manager

NC R13: Non-toxic Pest Treatment Applied to Lumber

Purpose

Provide added protection for wood-framed members in contact with building foundation.

Criteria

Provide added termite protection for wood-framed structures by applying a borate pest treatment to the lumber. Alternative termite products will be considered on a case-by-case basis.

Select one option:**A. Applied to Lumber in Contact with Foundation**

All wood framing and sheathing in contact with the foundation and at least 3 feet above should have factory or field applied borate.

B. Applied to ALL Lumber

All wood framing should have factory or field applied borate. Sheathing in contact with the foundation and at least 3 feet above should also have field applied borate.

Verification

- Provide product specification for factory applied borate
- Inspection by Project Manager

NC R14: Non-toxic Mold Inhibitor Applied to Lumber

Purpose

Prevent structural damage due to mold infestation.

Criteria

Apply a warranty-backed, non-toxic mold inhibitor to all structural wood.

Verification

- Provide product specification for factory applied mold inhibitor
- Provide mold inhibitor warranty to Project Manager and building owner/operator ▪ Inspection by Project Manager

NC R15: Third-party Test and Balance Report for All New HVAC Systems

Purpose

Ensure HVAC systems are providing airflow rates as designed.

Criteria

Retain an independent, third-party testing agent to perform a Test and Balance of the system's airflow distribution for all field-installed ductwork. Refer to [ES R5: Duct System Requirements](#) for a complete list of ductwork requirements.

At minimum, the report should include the following Design and Actual values:

- Supply airflow for each air handling unit and each register
- Return airflow for each air handling unit and each register
- Outside airflow for each air handling unit
- Exhaust rates per fan and each register
- Minimum and maximum airflows for terminal units

Verification

Copy of Test and Balance Report

NC R16: Mold Resistant Materials

Purpose

Reduce potential for mold growth.

Criteria

Select one or both of the options below:

- **Wet Areas**
No paper-faced gypsum board installed in wet areas. Tile backing material must be either fiber fiber-reinforced cement backer board or a product that is mold and moisture resistant.
- **All Gypsum Board is Paperless**

Definitions

Wet Areas - any rooms with toilets, urinals, sinks or showers.

Verification

Construction Documents detail location of mold-resistant materials

Photo of materials installation if not able to be visually documented by Project Manager Inspection by Project Manager

NC R17: Complete Insulation Coverage

Purpose

Reduce energy loss and increase building durability by creating a complete thermal boundary at the building envelope.

Criteria

The building thermal envelope is comprised of two components: insulation and an air barrier. All insulation must be complete (no gaps or missing pieces) and in direct contact with the building's continuous air barrier.

The quality of the application will be graded upon inspection: Grade I, II, or III (refer to [Appendix F: Insulation Grading](#)) for more information on insulation grading). Ensure careful installation at narrow cavities and cavities that contain plumbing or electrical work.

Meet the following, as applicable:

Insulation Application

Installation must be a minimum of Grade II quality. Any project receiving a Grade III upon inspection must resolve deficiencies and supply photos to demonstrate that corrections have been made. Points can be achieved for excellent installation under [BE 6: Install Insulation to Grade I Quality](#).

Loose-fill Attic Insulation

Any applied loose-fill attic insulation must have an attic card (listing type of insulation, bag count and appropriate depth) located near access and rulers present every 300 square feet. Loose-fill insulation should not be used for ceilings with a slope greater than 3:12.

Band/Rim Joists

Band/rim joists must be insulated to a minimum of R-13, regardless of energy code compliance pathway.

Exterior Metal Structural Members

Ensure insulation coverage is continuous at exterior metal structural members.

Chase Penetrations

All chases must be completely sealed and insulated where they penetrate the building thermal envelope.

Cantilevers and Overhangs

Ensure there is complete insulation coverage where cantilevers or overhangs intersect with blocking above supporting wall.

Parapet Walls

Insulation must be in direct contact with the building's continuous air barrier.

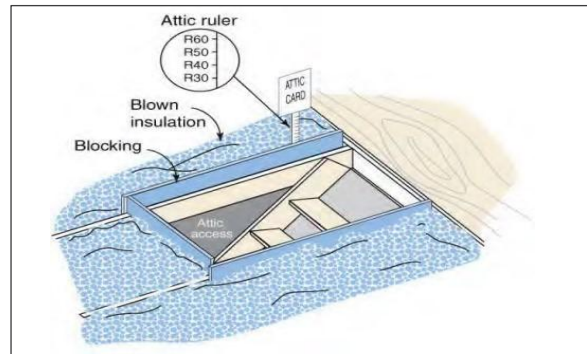
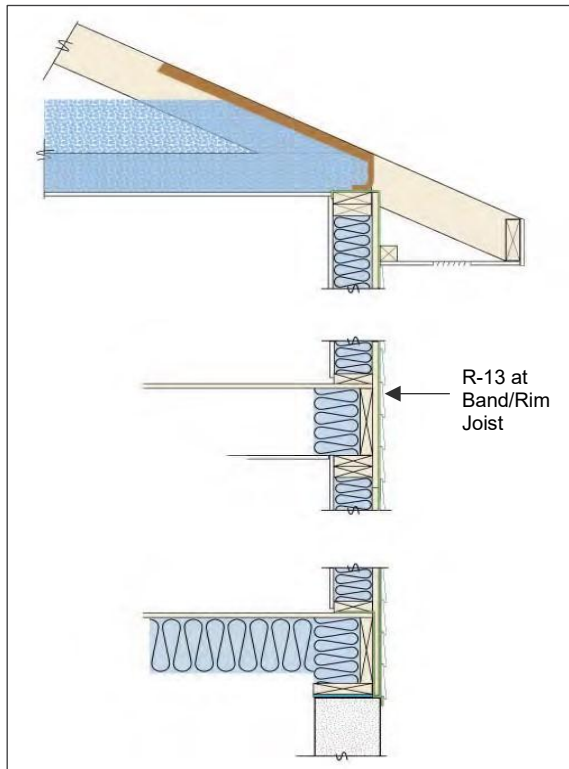

Insulated Attic

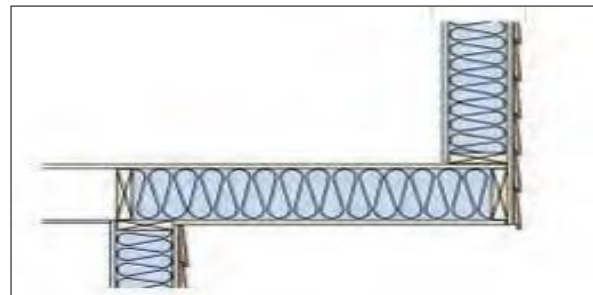

Cantilever Floor Area

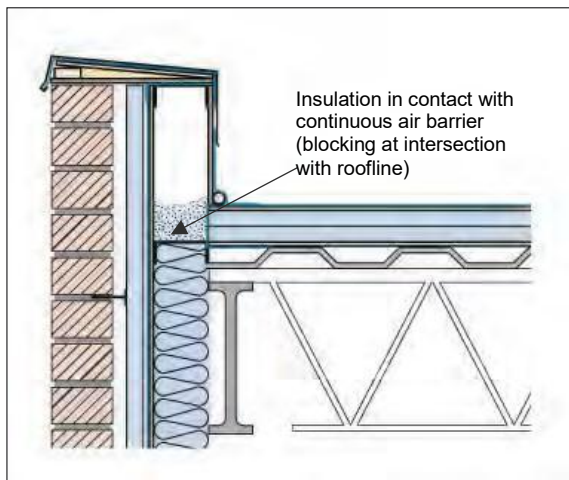

Parapet: Example 1

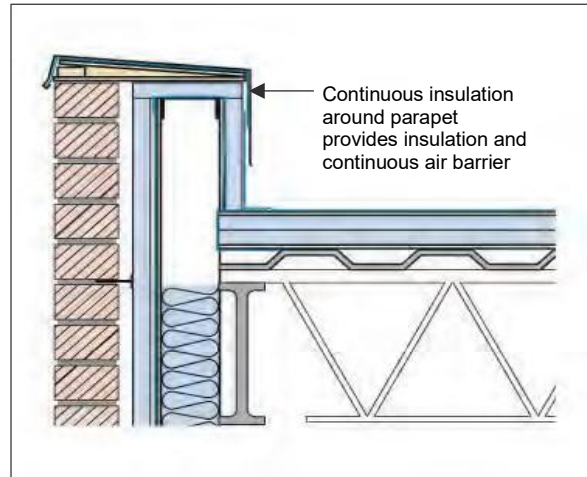

Parapet: Example 2

Resources

North American Insulation Manufacturers Association (NAIMA) www.naima.org

Verification

Construction Documents clearly detail insulation requirements

Provide photos of exterior insulation installation that cannot be visually verified on site visits

Inspection by Project Manager

NC R18: Minimum Thermal Break for Steel Stud Framing

Purpose

Minimize the thermal bridging effect and associated potential moisture problems at the building thermal envelope.

Criteria:

Projects in all climate zones (2a, 3a, and 4a) that have steel stud framing at the building thermal envelope must have a minimum thermal break in the form of exterior continuous insulation, regardless of energy code compliance pathway.

The following are minimum required R-values based on the project's compliance pathway and geographical climate zone:

Minimum R-7.5 Thermal Break

For projects that select the Prescriptive path for energy code compliance.

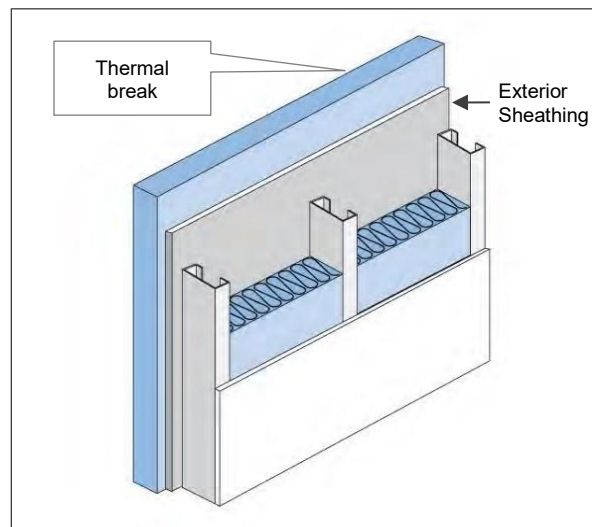

Steel Stud Framed Wall Section

Verification

Construction Documents indicate location and R-value of thermal break

Provide photos of thermal break installation if it cannot be visually verified

Inspection by Project Manager

NC R19: Continuous Air Barrier

Purpose

Improve overall envelope performance and minimize energy loss with an air-tight barrier.

Criteria

The building thermal envelope is comprised of two components: insulation and an air barrier. In order to work effectively as the thermal envelope, these two components must be continuous and in constant contact.

Different building materials can act as an air barrier (e.g. drywall, building wrap or sheathing) and sometimes an air barrier can also act as insulation (e.g. rigid insulation board). Assemblies often have more than one material acting as an air barrier. For instance, a wall assembly may include drywall, OSB sheathing, rigid exterior insulation and building wrap, however only one surface is considered to be the primary air barrier. This primary air barrier must be complete and continuous across all portions of the building thermal envelope.

Any gaps or missing pieces in the building's continuous air barrier could compromise envelope performance test results required for certification (refer to [BE R3: Envelope Air Tightness Performance Test](#) for maximum leakage requirement). Transitions from roofs to walls, walls to floors or between different materials should be carefully considered and detailed, as these are common leakage locations. Suspended ceilings are not considered air barriers.

Meet the following:

Continuous Air Barrier – Sealed and/or Taped

Continuous insulation, sheathing, or other material acting as primary air barrier shall be installed with all seams and edges sealed and/or taped – OR – sealed with continuous fluidapplied air barrier. The following are acceptable continuous air barrier materials:

- Plywood – minimum 3/8 inch
- OSB – minimum 3/8 inch
- Extruded polystyrene insulation board – minimum 1/2 inch
- Foil-faced urethane insulation board – minimum 1/2 inch
- Exterior gypsum sheathing or interior gypsum board – minimum 1/2 inch
- Cement board – minimum 1/2 inch
- Built up roofing membrane
- Modified bituminous roof membrane
- Fully adhered single-ply roof membrane
- Portland cement/sand parge, stucco or gypsum plaster – minimum 1/2 inch thick
- Cast-in-place and precast concrete
- Concrete masonry walls either fully grouted or painted to fill the pores
- Assembly with an air leakage that does not exceed 0.040 cubic feet per square foot per minute under a pressure differential of 0.3 inch water column - and in certain circumstances, a vapor permeance of more than 1 perm (manufacturer data required)

Bottom Plate Sealed

For all walls that separate conditioned and unconditioned spaces, seal bottom plates to slab or subfloor.

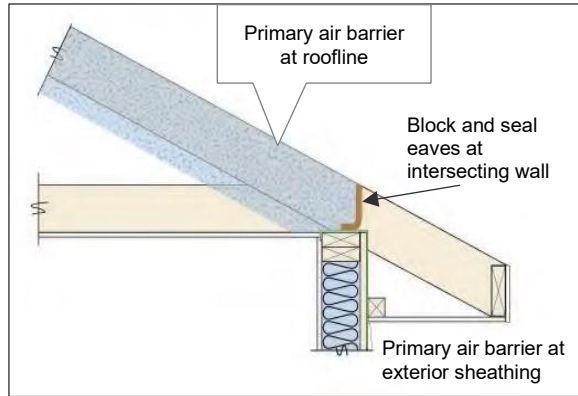

Continuous Air Barrier - Unvented Attic

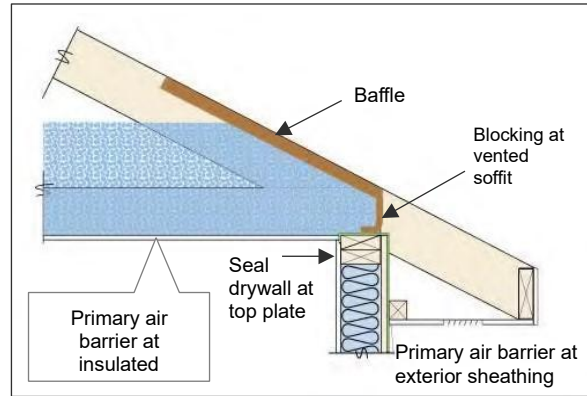

Continuous Air Barrier - Vented Attic

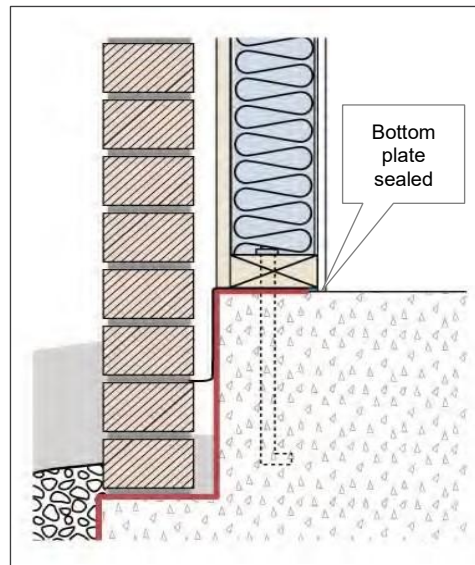

Bottom Plate Sealed to Slab

Definitions

Continuous Air Barrier – the combination of primary air barrier materials that make up the portion of the building envelope that provides overall airtightness of the building and separates conditioned and unconditioned space.

Resources:

ASHRAE Standard 90.1-2010, section 5.4.3 Air Leakage www.ashrae.org

Verification

Construction Documents clearly indication location and type of continuous air barrier(s)
 Provide photos of the continuous air barrier installed prior to the 1st Site Visit that cannot be visually verified
 Inspection by Project Manager

NC R20: Rigid Air Barriers

Purpose

Improve overall envelope performance and minimize energy loss by using additional air-tight barriers at “problem areas.”

Criteria

Apply rigid air barriers at the following areas, as applicable:

Tub and Shower Areas

Install rigid interior air barrier behind tubs and showers on insulated walls before installing tub and shower assemblies. Install insulation prior to enclosing the cavity.

Cantilevers and Overhangs

All cantilevers and overhangs must have a rigid air barrier (blocking) installed at intersection with supporting wall.

Kneewall Areas

A wall adjacent to a vented attic space is considered to be a kneewall and should be treated as part of the building thermal envelope. Apply an attic-side rigid air barrier to all kneewalls and seal the seams of the air barrier to reduce air infiltration. Install blocking beneath ceiling joists underneath kneewall.

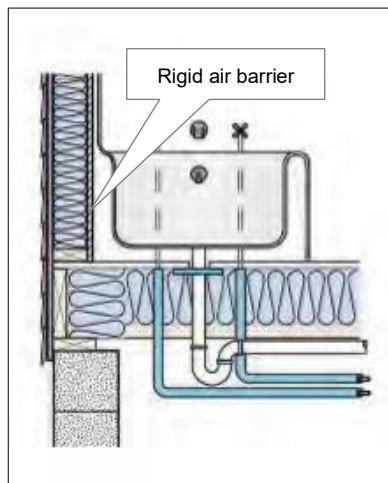

Exterior Wall at Tub Area

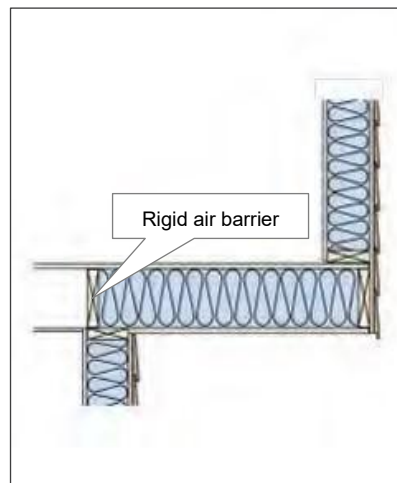

Cantilever Floor Area

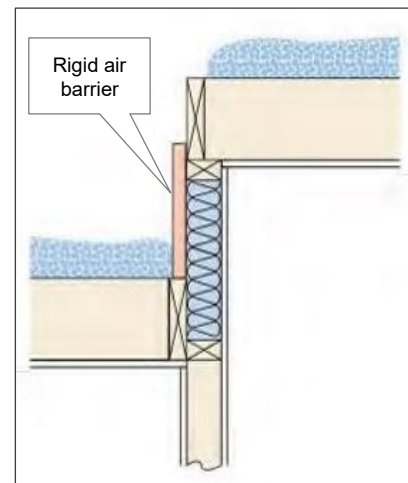

Kneewall Area at Raised Ceiling

Verification

Construction Documents clearly detail rigid air barrier components

Inspection by Project Manager

NC R21: Attic Insulation and Air Sealing

Purpose

Reduce energy loss and increase building durability by insulating and air sealing accessible attics to ASHRAE 90.1-2007 or applicable residential standard.

Criteria

The building thermal envelope is comprised of two components: insulation and an air barrier. All insulation must be complete (no gaps or missing pieces) and in direct contact with the building's continuous air barrier. In vented attics the air barrier is typically the finished ceiling. It may be necessary to remove existing insulation to perform air sealing.

The quality of the application will be graded upon inspection: Grade I, II, or III (refer to [Appendix F: Insulation Grading](#)) for more information on insulation grading). Ensure careful installation at narrow cavities and cavities that contain plumbing or electrical work.

Meet the following, as applicable:

Insulation Application

Installation must be a minimum of Grade II quality. Any project receiving a Grade III upon inspection must resolve deficiencies and supply photos to demonstrate that corrections have been made. Points can be achieved for excellent installation under [BE 6: Install Insulation to Grade I Quality](#).

Loose-fill Attic Insulation

Any applied loose-fill attic insulation must have an attic card (listing type of insulation, bag count and appropriate depth) located near access and rulers present every 300 square feet. Loose-fill insulation should not be used for ceilings with a slope greater than 3:12.

Chase Penetrations

All chases must be completely sealed and insulated where they penetrate the building thermal envelope.

Pay particular attention to air sealing in the following areas:

Tongue and groove ceilings must be sealed from the attic side prior to insulation application Attic access (doors and pull down stairs) should be weatherstripped

Vented attics need to include baffles to prevent wind washing and to prevent vent damming

Seal HVAC boot penetrations

Seal recessed/can lighting (replace old can lights with IC rated air tight cans)

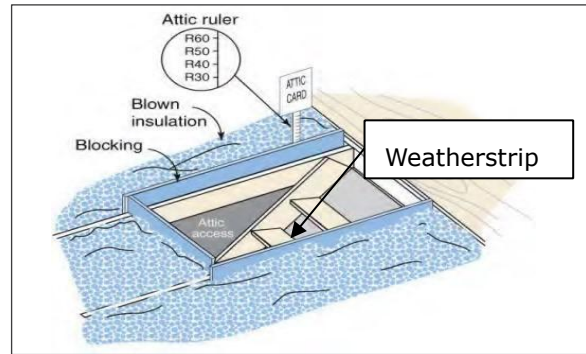
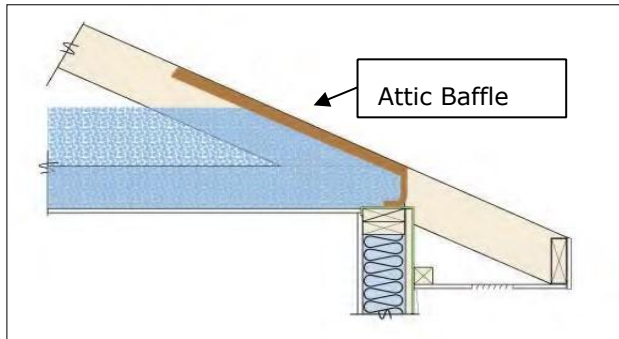

Insulated Attic

Top plates should be caulked to finished ceiling **Resources**

North American Insulation Manufacturers Association (NAIMA) www.naima.org

Verification

Construction Documents clearly detail insulation requirements

Inspection by Project Manager

Appendix A: COMcheck Overview

COMcheck is commercial energy code compliance software developed by Pacific Northwest National Laboratory for the U.S. Department of Energy's Office of Codes and Standards. COMcheck can be used to demonstrate a commercial project design complies with ASHRAE Standard 90.1-2007. The software provides a highly flexible way to demonstrate compliance with minimal input. The envelope section allows tradeoffs between envelope components, including roofs, walls, windows, floors, and skylights. The lighting section enables you to quickly determine if your lighting design meets interior-lighting power limits. The mechanical section enables you to assemble a customized list of code requirements that are applicable to the systems and equipment in your building.

How To Download

COMcheck can be downloaded from www.energycodes.gov, projects are required to use version 3.9.0 or later (the version number can be found in the upper left corner).

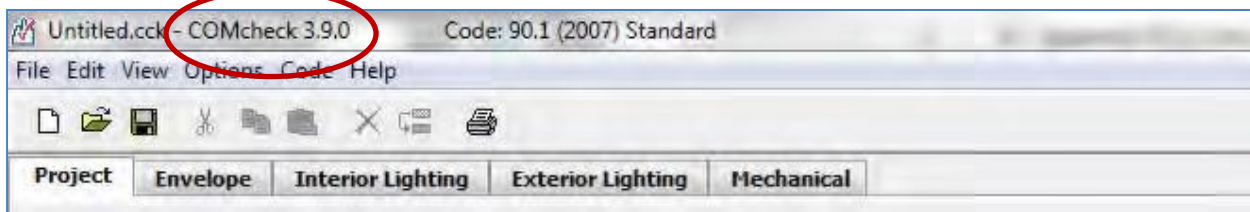

Code Menu

Use the Code menu to select which code version you want the program to use when determining compliance. All ECLC projects should use ASHRAE Standard 90.1-2007.

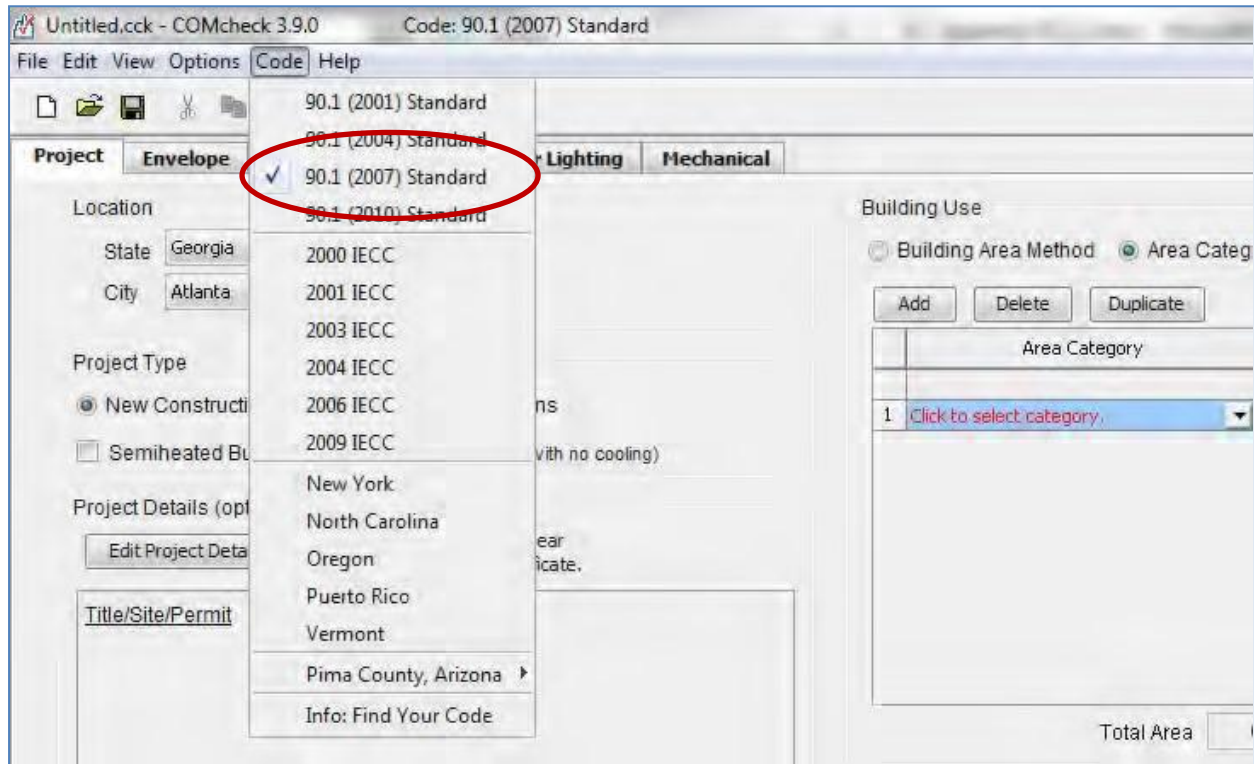

Project Screen

The Project screen is used to provide the software with information such as the location of the proposed building (state and city) and the building use category and area. You may also enter specific project information that identifies and describes your project which will be printed on your certificate.

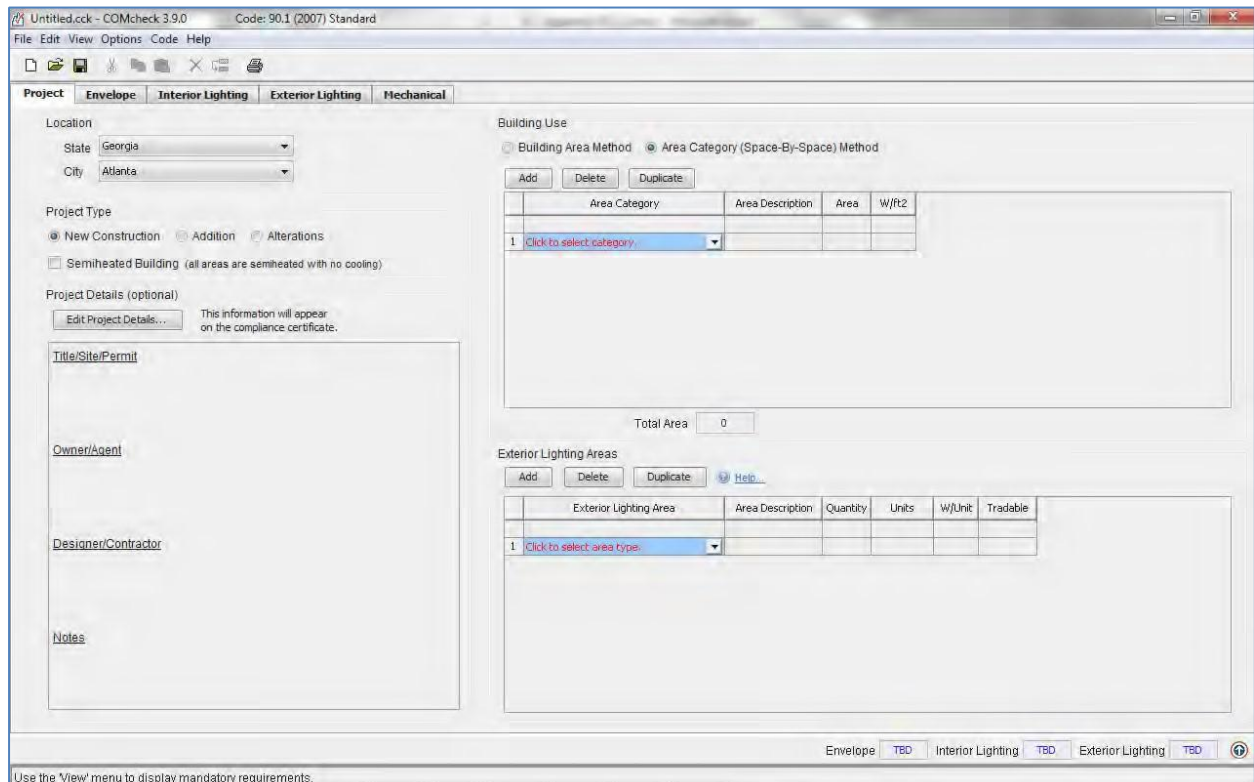

Location

The software lists the available cities for each state. If your city is not listed, choose the closest city with similar weather conditions.

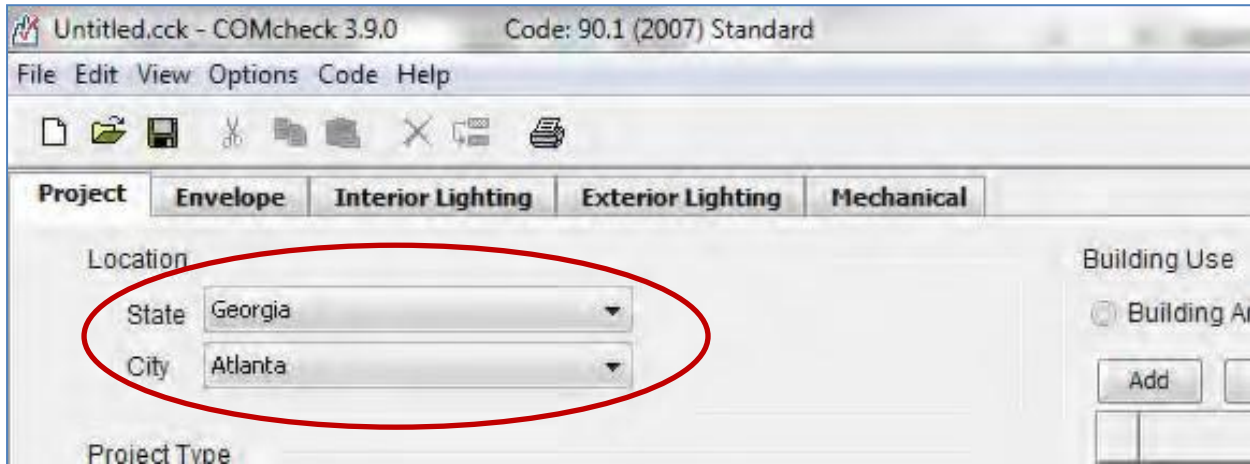

Project Type

Projects should select New Construction, Addition or Alterations. The selection will be included on the compliance report although the trade-off calculations remain the same for New Construction and Addition.

Additions are treated the same way as New Construction, ignoring the common walls between the existing building and the addition. All new systems being added must be entered in the software and must comply with the requirements. Existing systems simply extended into an addition do not have to be included.



Alterations include only those envelope components, lighting fixtures, or mechanical systems and equipment that will exist upon completion of the alteration project. Compliance is shown as Pass/Fail for Envelope and Lighting.

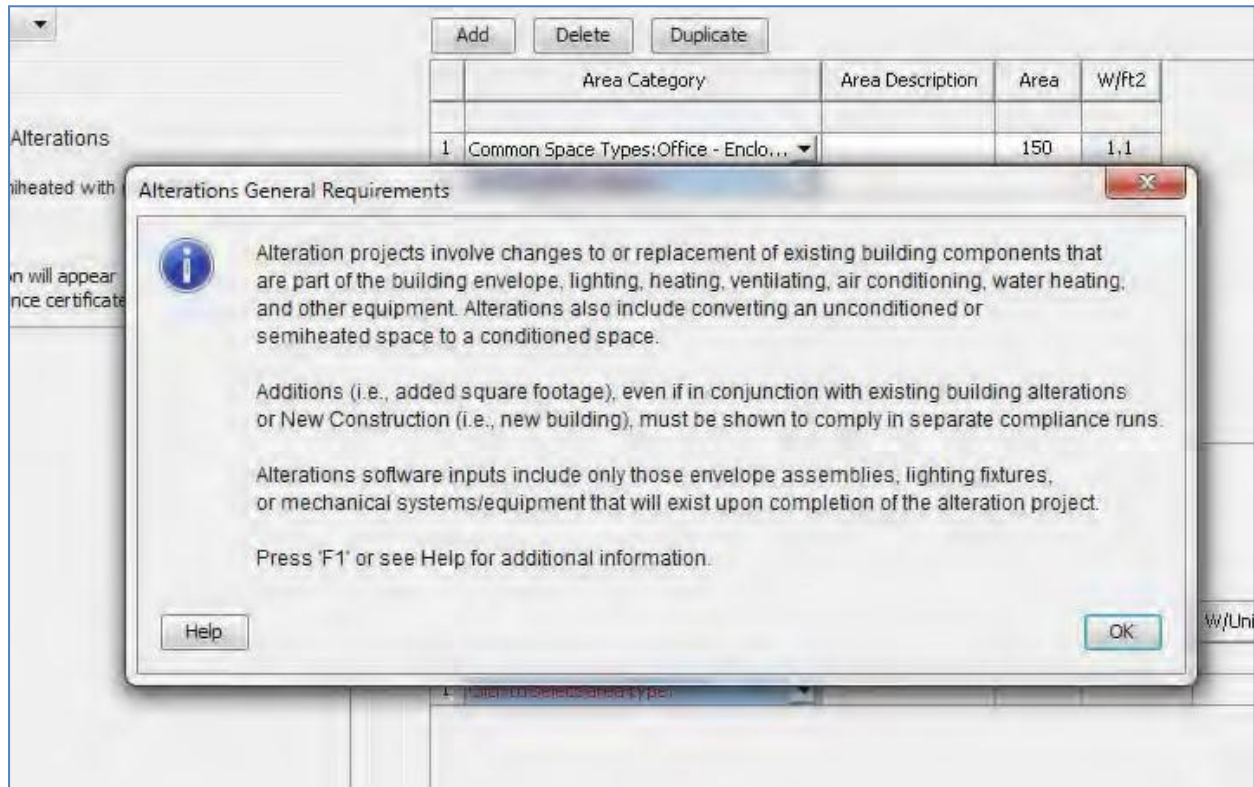

Project Details

The Project Details section has input fields entitled Title/Site/Permit, Owner/Agent, and Designer/Contractor. All of the information entered in these fields is included in your project report. None of this information is required by the software program to determine compliance with the code. This information may be useful, however, to the building department or as a way to track and label your reports.

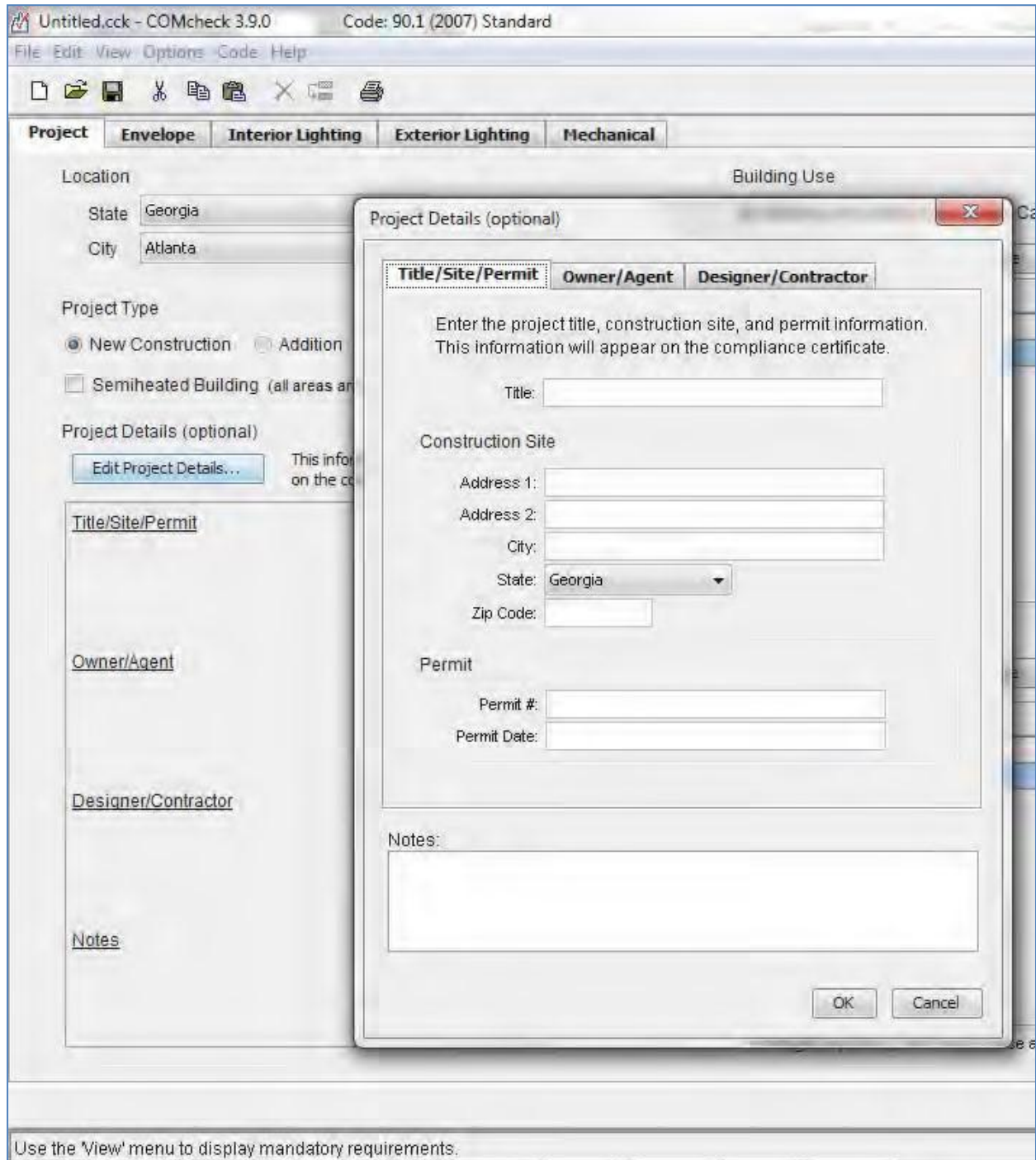

Building Use

Use the Whole Building compliance method for buildings that entirely match one of the available building types or use the Area Category (Space-By-Space) compliance method when detailed information about space usage is available. The ECLC program participants are encouraged to use the Area Category (Space-By-Space) Method. A list of building types or area categories is displayed when you click the left mouse button in the Whole Building Type or Area Category column of the Building Use table. Fill in the square footage of the whole building or each space.

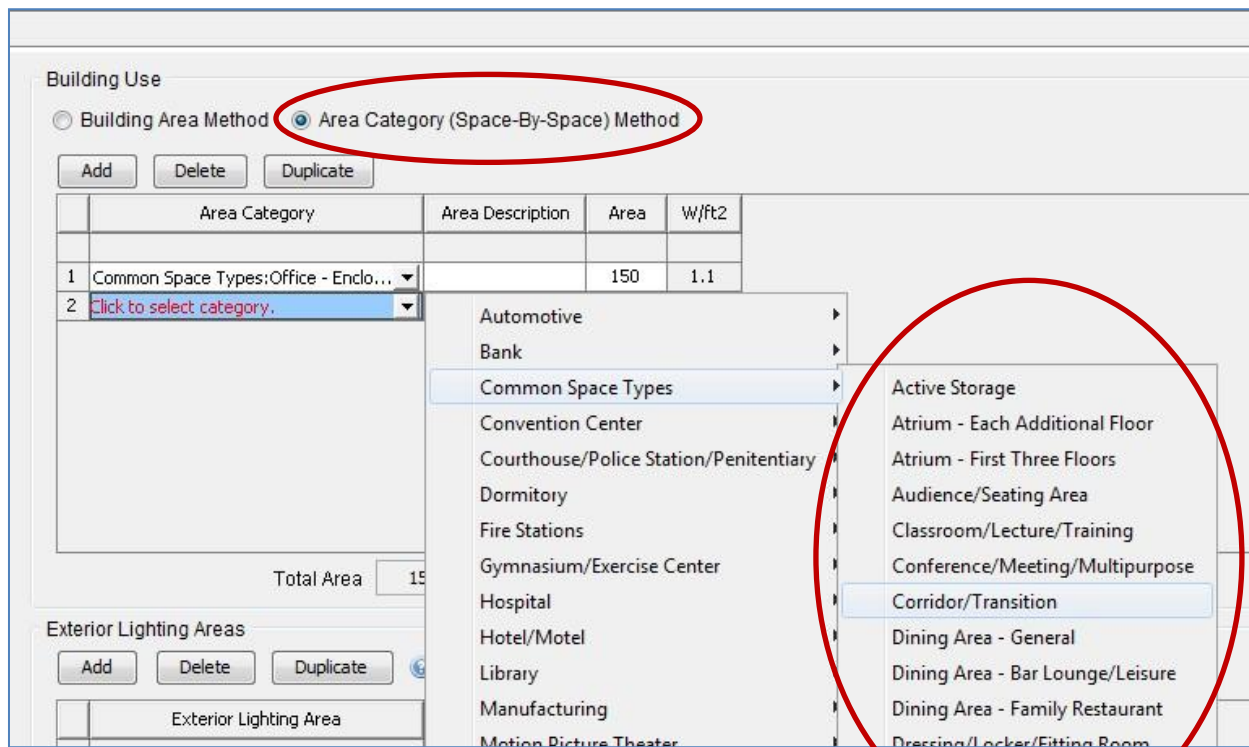
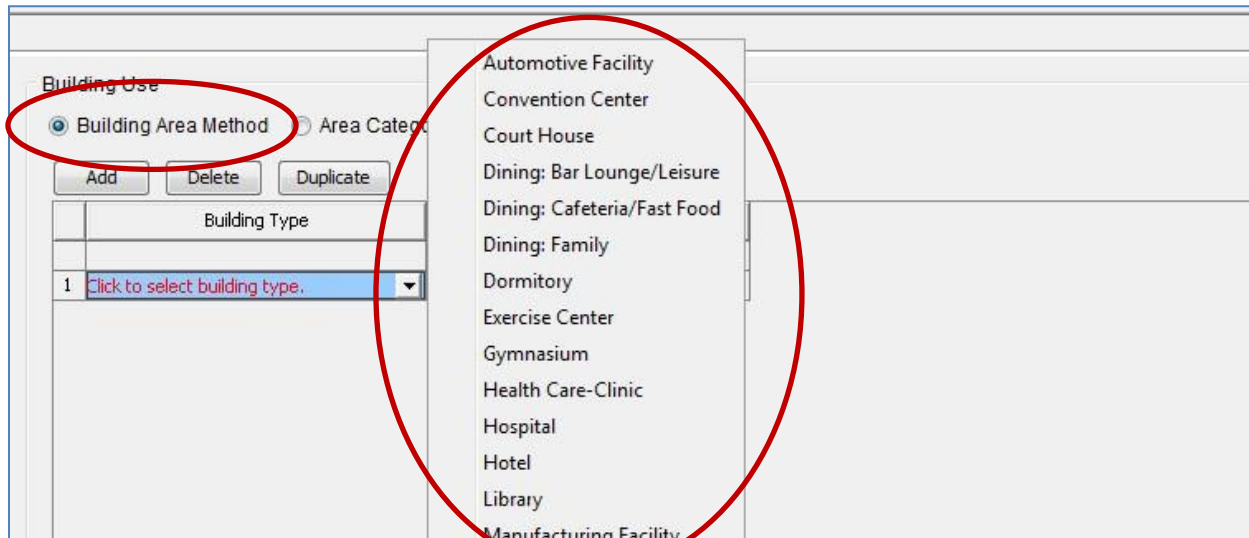

Select the applicable Exterior Lighting Areas and enter the appropriate quantities.

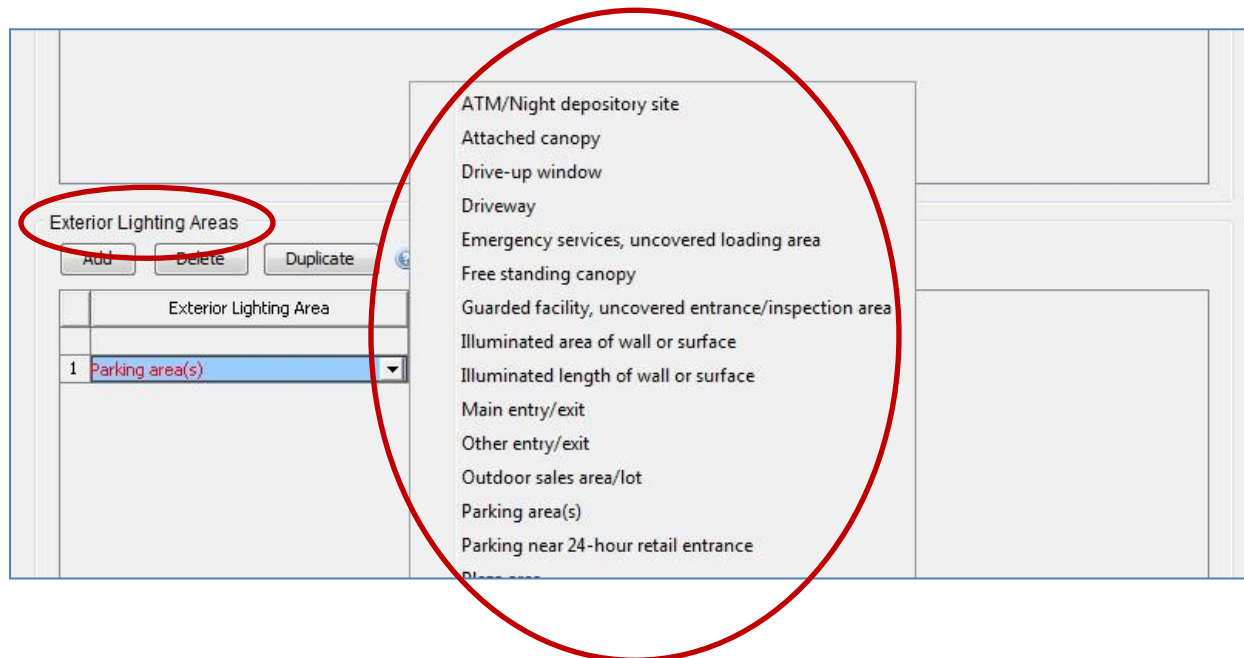

Once all the information is completed on the Project Screen the building can be evaluated on energy code compliance for the following components:

- Envelope
- HVAC
- Service water heating
- Interior lighting
- Exterior lighting

Appendix B: COMcheck Envelope

Use COMcheck to demonstrate that the building envelope complies with ASHRAE Standard 90.1-2007 either prescriptively or through the simple trade-off approach.

Prescriptive Envelope Values

The following are Nonresidential prescriptive envelope values for climate zones 2, 3 and 4. Refer to ASHRAE Standard 90.1-2007 to Table 5.5 for Residential or Semi-heated prescriptive envelope values.

Nonresidential Building Envelope Requirements

Opaque Elements	Climate Zone 2		Climate Zone 3		Climate Zone 4	
Roofs						
Insulation Above Deck	R-20 c.i.		R-20 c.i.		R-20 c.i.	
Metal Building Roofs	R-19		R-19		R-19	
Attic and Other	R-38		R-38		R-38	
Above-Grade Walls						
Mass Walls	R-5.7 c.i.		R-7.6 c.i.		R-9.5 c.i.	
Metal Building Walls	R-13		R-13		R-13	
Steel-framed Walls	R-13*		R-13 + R 3.8 c.i.		R-13 + R 7.5 c.i.	
Wood-framed Walls	R-13		R-13		R-13	
Below-Grade Walls						
Below-grade Walls	NR		NR		NR	
Floors (over unconditioned space)						
Mass Floors	R-6.3 c.i.		R-6.3 c.i.		R-8.3 c.i.	
Steel-joist Flooring	R-19		R-19		R-30	
Wood-framed Flooring	R-19		R-19		R-30	
Slab-On-Grade Floors						
Unheated	NR		NR		NR	
Heated	R-7.5 for 12 in.		R-10 for 24 in.		R-15 for 24 in.	
Opaque Doors						
Swinging	U-0.70		U-0.70		U-0.70	
Non-swinging	U-1.45		U-1.45		U-1.50	
Fenestration	Climate Zone 2		Climate Zone 3		Climate Zone 4	
	Max U	Max SHGC	Max U	Max SHGC	Max U	Max SHGC
Vertical Glazing, ≤ 40% of Wall						
Nonmetal framing	U-0.75	SHGC-0.25 all	U-0.65	SHGC-0.25 all	U-0.40	SHGC-0.25 all
Metal Framing (curtainwall/storefront)	U-0.70		U-0.60		U-0.50	

Metal framing (entrance door)	U-1.10		U-0.90		U-0.85	
Metal framing (all other)	U-0.75		U-0.65		U-0.55	
Skylight with Curb, Glass, % of Roof						
0%-2.0%		SHGC-0.36		SHGC-0.39		SHGC-0.49
2.1%-5.0%	U-1.98 all	SHGC-0.19	U-1.17 all	SHGC-0.19	U-1.17 all	SHGC-0.39
Skylight with Curb, Plastic, % of Roof						
0%-2.0%		SHGC-0.39		SHGC-0.65		SHGC-0.65
2.1%-5.0%	U-1.90 all	SHGC-0.34	U-1.30 all	SHGC-0.34	U-1.30 all	SHGC-0.34
Skylight without Curb, All, % of Roof						
0%-2.0%		SHGC-0.36		SHGC-0.39		SHGC-0.49
2.1%-5.0%	U-1.36 all	SHGC-0.19	U-0.69 all	SHGC-0.19	U-0.69 all	SHGC-0.39

**refer to BE R2: Minimum Thermal Break for Steel Stud Framing for additional thermal break requirements
c.i. = continuous insulation NR = not required*

Envelope Screen

Use the buttons at the top of the Envelope screen to create a list of building components present in your proposed design. Each component you select is added to the building components displayed on the Envelope screen. For each component, enter appropriate values for all fields with white. These fields may include the assembly type, gross area (or perimeter), cavity R-value, continuous R-value, assembly U-factor, construction details, SHGC solar heat gain coefficient, and/or projection factor.

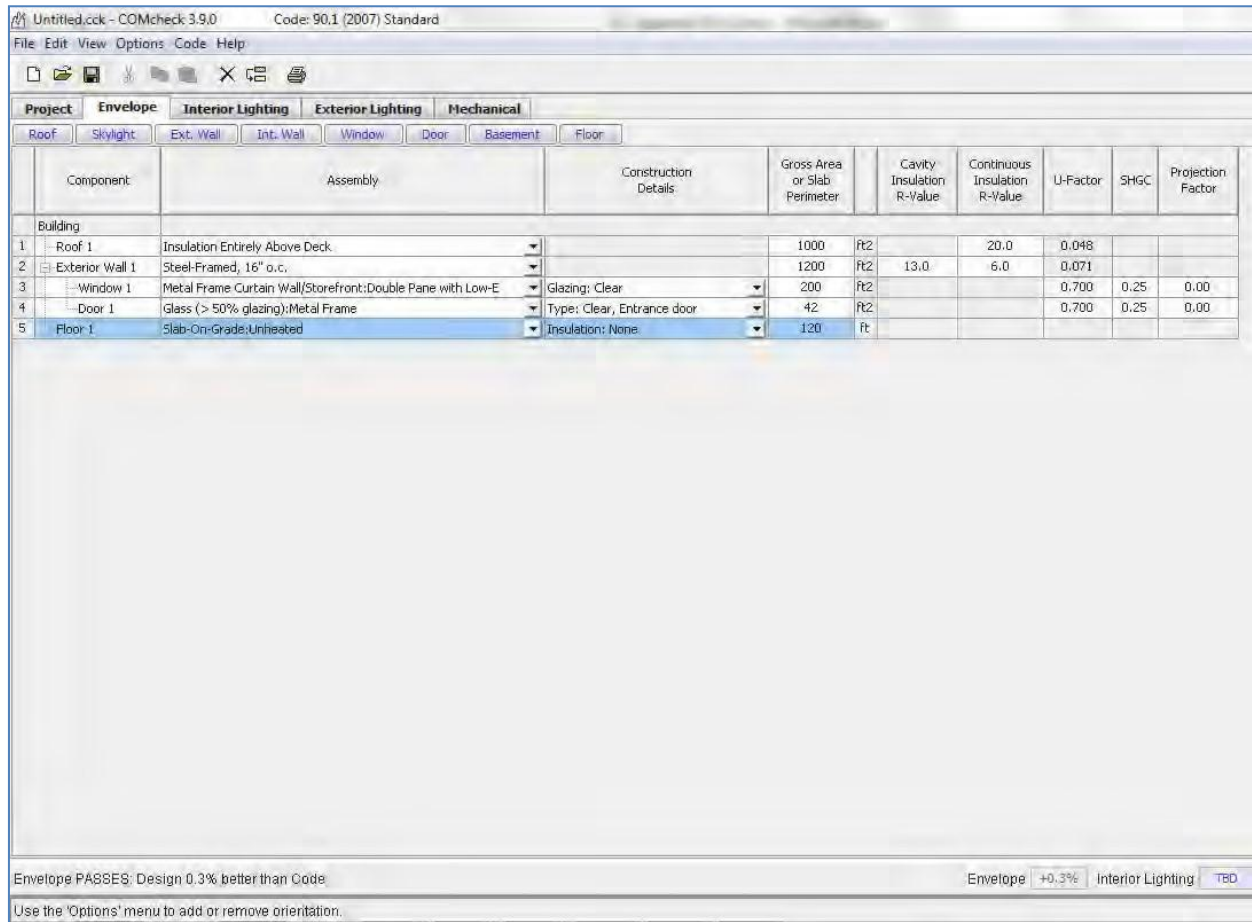

Concrete slab-on-grade components require a perimeter entered in linear feet (ft). All other components require an area entered in square feet (ft²). The cavity R-value input is used for insulation placed between structural members, while the continuous R-value input is used for insulation that is continuous across the structure such as rigid-roof insulation or insulating wall sheathing.

After you have completed the description of each new component, the program automatically updates the compliance results. The results are displayed at the bottom of the screen in the *Envelope* box. If *TBD* (to be determined) is displayed in this field, you have not filled in all necessary fields. To determine which data are missing or invalid, look for fields with white-on-red text. In addition to providing inputs for all white-on-red fields, you must select at least one building use type and provide its area on the *Project* screen before the software can determine compliance.

Projection Factor

Projection factors can be used to reduce the SHGC requirements. To calculate the projection factor, take the exterior horizontal shading projection depth divided by the sum of the height of the fenestration and the distance from the top of the fenestration to the bottom of the external shading projection in units consistent with the projection depth.

$$PPPPPPPPPPPP = \frac{A}{B} = \frac{6}{8} \rightarrow 77\%$$

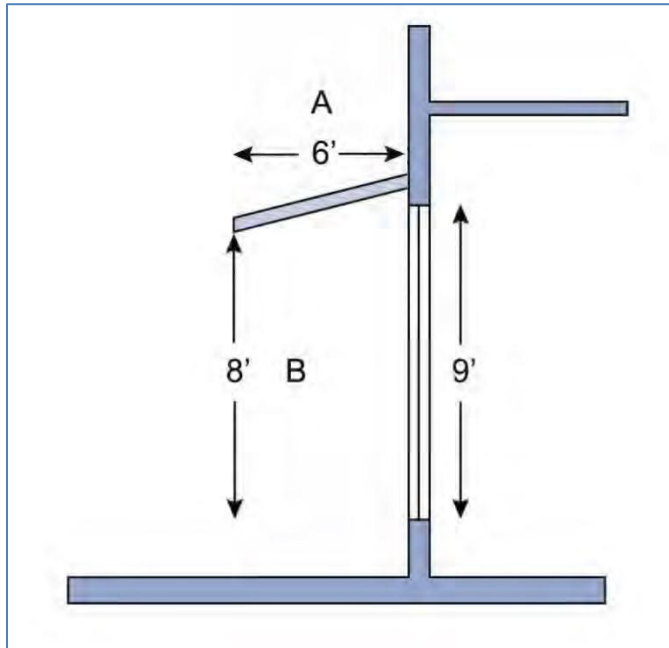

Envelope Alterations

Envelope alteration exceptions may be taken if the project chooses “Alterations” under project type. Include only the components that will exist after alterations are complete. As you enter the applicable components, alteration detail dialogs will appear asking that the appropriate alteration option be selected that may include one or more exemptions to code compliance for that component. Depending on which option is selected, the dialogs may change and further details may need to be entered.

Roof Alterations

The alteration detail dialog for roof components requires that the appropriate option be selected. Depending upon the roof assembly type, the options may include the following:

- Alteration replaces a roof membrane that DOES NOT expose the sheathing/deck or rooftop insulation
- Alteration replaces a roof membrane where insulation exists below the roof sheathing/deck
- Alteration exposes a roof cavity but the cavity is completely filled with minimum R-3/inch insulation
- No exemptions apply to this assembly.

Skylight Alterations

The alteration detail dialog for skylight Glazing requires that the appropriate option be selected. The options include the following:

- Alteration ONLY replaces glazing (i.e., glass units) in existing sash or frame. To claim this exemption, the 'altered' skylight U-factor and SHGC solar heat gain coefficient cannot be higher than that of the replaced glazing.
- Alteration replaces less than 25% of existing fenestration area (glass plus frame). To claim this exemption, the replaced skylight U-factor and SHGC cannot be higher than that of the original glazing AND the percent of skylight area replaced must qualify.
- No exemptions apply to this assembly.

Exterior Wall Alterations

The alteration detail dialogs for exterior and interior wall Opaque portion of the building envelope components require that the appropriate option be selected. The options include the following:

- Alteration modifies wall areas without an existing cavity and no cavity will be created
- Alteration exposes a wall cavity but the cavity is completely filled with minimum R-3/inch insulation
- No exemptions apply to this assembly.

Window Alterations

The alteration detail dialog for windows requires that the appropriate option be selected. The options include the following:

- Alteration ONLY installs storm windows over existing glazing
- Alteration ONLY replaces glazing (i.e., glass units) in existing sash or frame. To claim this exemption, the 'altered' window SHGC cannot be higher than that of the original glazing.
- Alteration replaces less than 25% of existing building fenestration area (glass plus frame). To claim this exemption, the altered window U-factor and SHGC cannot be higher than that of the original glazing AND the percent of vertical fenestration area (windows + glass doors) replaced must qualify.
- No exemptions apply to this assembly.

Basement Wall Alterations

The alteration detail dialog for basement walls requires that the appropriate option be selected. The options include the following:

- Alteration modifies wall areas without an existing cavity and no cavity will be created
- Alteration exposes a wall cavity but the cavity is completely filled with minimum R-3/inch insulation
- No exemptions apply to this assembly.

Floor Alterations

The alteration detail dialog for floor components requires that the appropriate option be selected. Depending upon the floor assembly type, the options may include the following:

- Alteration modifies floor areas without an existing cavity and no cavity will be created

- Alteration exposes a floor cavity but the cavity is completely filled with minimum R-3/inch insulation
- No exemptions apply to this assembly.

Envelope Compliance Certificate

Print an Envelope Compliance Certificate when all envelope component inputs are complete and the project PASSES code. Click on the File menu and choose View / Print Report.

Check or indicate Not Applicable for every item under Section 3: Requirements Checklist and sign/date under Section 4: Compliance Statement.

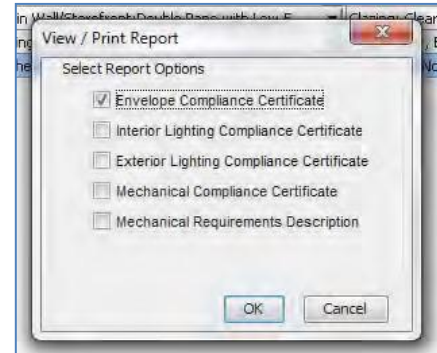

Sample Envelope Compliance Certificate



COMcheck Software Version 3.9.0
Envelope Compliance Certificate

90.1 (2007) Standard

Section 1: Project Information

Project Type: **New Construction**
Project Title : Sample Project

Construction Site: 1000 Peachtree Street Atlanta, GA 30308	Owner/Agent: Joe Owner	Designer/Contractor: Joe Contractor
--	---------------------------	--

Section 2: General Information

Building Location (for weather data):	Atlanta, Georgia
Climate Zone:	3a
Building Type for Envelope Requirements:	Non-Residential
Vertical Glazing / Wall Area Pct.:	20%

Building Type	Floor Area
Office	1000

Section 3: Requirements Checklist

Envelope **PASSES**. Design 0.3% better than code

Climate-Specific Requirements:

Component Name/Description	Gross Area or Perimeter	Cavity R-Value	Cont. R-Value	Proposed U-Factor	Budget U-Factor ^(a)
Roof 1: Insulation Entirely Above Deck	1000	---	20.0	0.048	0.048
Exterior Wall 1: Steel-Framed, 16" o.c.	1200	13.0	6.0	0.071	0.084
Window 1: Metal Frame Curtain Wall/Storefront Double Pane with Low-E, Clear, SHGC 0.25	200	---	---	0.700	0.600
Door 1: Glass (> 50% glazing): Metal Frame, Clear, Entrance Door, SHGC 0.25	42	---	---	0.700	0.900
Floor 1: Slab-On-Grade: Unheated	120	---	---	---	---

(a) Budget U-factors are used for software baseline calculations ONLY, and are not code requirements.

Insulation:

- N/A 1. Open-blown or poured loose-fill insulation has not been used in attic roof spaces with ceiling slope greater than 3 in 12.
- N/A 2. Wherever vents occur, they are baffled to deflect incoming air above the insulation.
- 3. Recessed lights, equipment and ducts are not affecting insulation thickness.
- N/A 4. No roof insulation is installed on a suspended ceiling with removable ceiling panels.
- 5. All exterior insulation is covered with protective material.
- N/A 6. Cargo and loading dock doors are equipped with weather seals.

Fenestration and Doors:

- 7. Windows and skylights are labeled and certified by the manufacturer for U-factor and SHGC.
- 8. Fixed windows and skylights unlabeled by the manufacturer have been labeled using the default U-factor and SHGC.
- N/A 9. Other unlabeled vertical fenestration, operable and fixed, that are unlabeled by the manufacturer have been site labeled using the default U-factor and SHGC. No credit has been given for metal frames with thermal breaks, low-emissivity coatings, gas fillings, or insulating spacers.

Project Title: Sample Project
Data filename: Untitled.cck

Report date: 11/22/11
Page 1 of 2

Sample Envelope Compliance Certificate

Air Leakage and Component Certification:

- 10. All joints and penetrations are caulked, gasketed, weather-stripped, or otherwise sealed.
 - 11. Windows, doors, and skylights certified as meeting leakage requirements.
 - 12. Component R-values & U-factors labeled as certified.
 - 13. 'Other' components have supporting documentation for proposed U-Factors.
 - N/A 14. Building entrances that separate conditioned space from the exterior have an enclosed vestibule with all doors equipped with self-closing devices. Interior and exterior doors in the closed position are no less than 7 ft apart. Conditioned vestibules comply with the requirements for a conditioned space. Unconditioned vestibules comply with the requirements of a semiheated space.
- Exceptions:*
- Building entrances with revolving doors.
 - Doors not intended to be used as a building entrance.
 - Doors opening directly from a dwelling unit.
 - Buildings less than four stories above grade and less than 10,000 ft² in area.
 - Doors that open directly from a space less than 3000 sq. ft. in area and is separate from the building entrance.

Section 4: Compliance Statement

Compliance Statement: The proposed envelope design represented in this document is consistent with the building plans, specifications and other calculations submitted with this permit application. The proposed envelope system has been designed to meet the 90.1 (2007) Standard requirements in COMcheck Version 3.9.0 and to comply with the mandatory requirements in the Requirements Checklist.

Joe Contractor - GC
Name - Title

Joe Contractor
Signature

11/22/11
Date

THIS PAGE LEFT INTENTIONALLY BLANK

Appendix C: COMcheck Mechanical

Use COMcheck to demonstrate that HVAC and Service Water Heating systems comply with ASHRAE Standard 90.1-2007. **HVAC System**

The HVAC System button helps you identify key characteristics of the HVAC systems in your building. The term HVAC systems refers to secondary HVAC systems, including controls, fans, terminal boxes, radiators, coils, and package HVAC equipment, not primary HVAC system components such as boilers, chillers, cooling towers, and pumps. The characteristics you select determine which requirements apply.

The HVAC System entries enable you to describe the HVAC system features in your building in sufficient detail to exclude large numbers of requirements that do not apply to your systems. The resulting simplification facilitates both designing for compliance with the code and code enforcement.

Round buttons (radio buttons) permit only one selection from each group, square boxes (checkboxes) permit multiple selections from a group of inputs, and gray text indicates that the option is unavailable because it is incompatible with other selection(s) that have been made on the current or a previous screen.

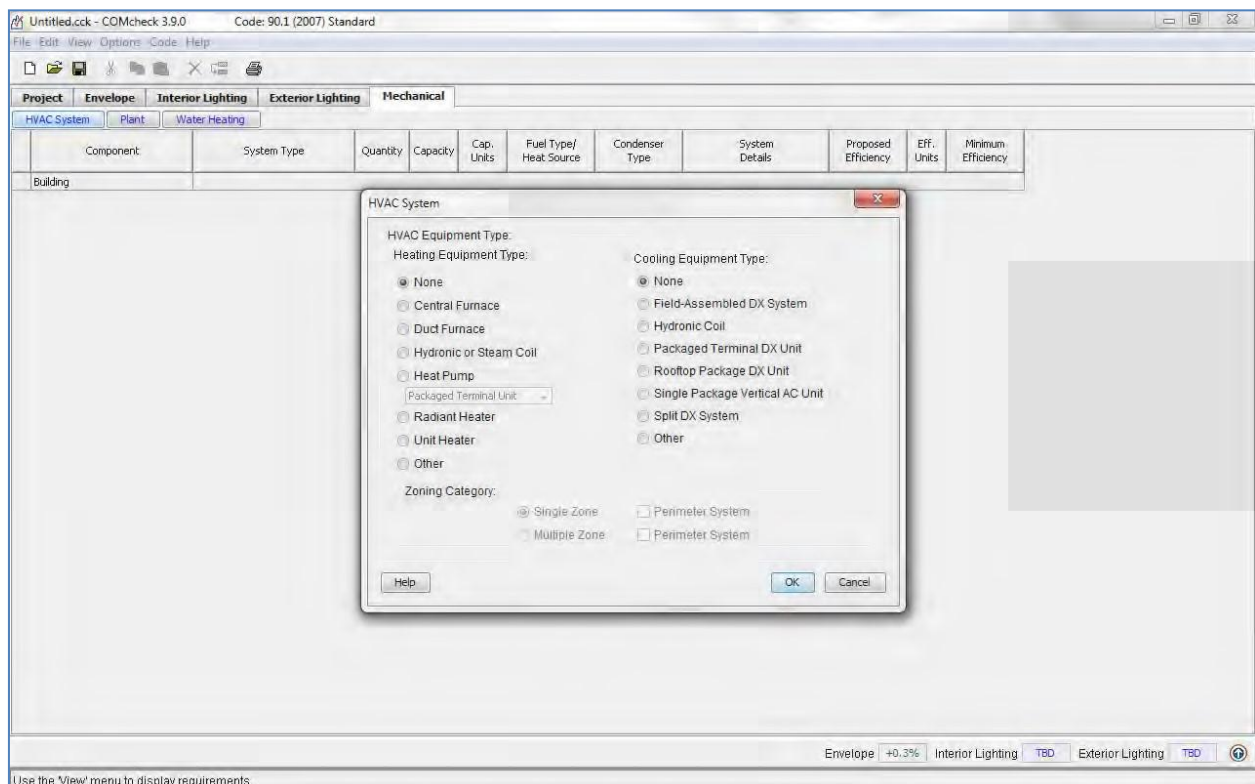

When multiple different HVAC systems are used within a single building, you may select the HVAC System button multiple times to enter more than one system. When multiple identical (or nearly identical) systems are used, describe them once and use the quantity field to indicate the number of such systems present.

Note that some of the inputs are interdependent. If you select Heat Pump as the Heating Equipment Type, you will not be able to select a Cooling Equipment Type because it is assumed to be DX (direct expansion). If you select Unit Heater for Heating Equipment Type or Packaged Terminal DX Unit for Cooling Equipment Type, you will not be able to select Multiple Zone A space or group of spaces within a building with any combination of heating, cooling, or lighting requirements sufficiently similar so that desired conditions can be maintained throughout by a single controlling device or check the Perimeter System box under Zoning Category because these equipment types are not compatible.

Heating Equipment Type

Central Furnace - A central furnace is a self-contained, indirect-fired or electrically heated furnace supplying heated air through ducts to spaces. A central furnace can be a stand-alone unit, but is typically integral to a rooftop-DX (direct expansion) system or split DX system air conditioner. Though less common, a central furnace may also contain a hydronic coil that would be used for air conditioning.

Duct Furnace - A duct furnace is a furnace normally installed in distribution ducts of air-conditioning systems to supply warm air. A duct furnace usually does not have its own supply fan and uses air supplied through the ducts by other supply fans such as a fan for a central air conditioner.

Hydronic or Steam Coil - A hydronic coil is an array of tubing, placed in a supply air stream, through which hot or cold water passes, heating or cooling the supply air stream to provide heating or air conditioning to a space. Hydronic coils, central furnaces, and DX coils are used in various configurations of heating and air-conditioning systems. A steam coil is an array of tubing, placed in a supply air stream, through which steam passes to provide heat to a space.

Heat Pump - A heat pump is a DX air conditioner with a reversing valve, allowing it to operate in two refrigeration modes. When the refrigeration system is reversed, the heat pump absorbs heat from the outdoor air and rejects it to the indoor environment, providing heat to the space. Heat pumps are manufactured in several configurations, including packaged terminal, rooftop package, split system, water loop, and ground coupled.

Packaged Terminal Unit - A packaged terminal heat pump (PTHP) is a self-contained heat pump typically installed through a wall. It discharges warm or cool air directly to the space without the use of ducts for distribution.

Rooftop Packaged Unit - A rooftop packaged heat pump is also known as a unitary singlepackaged heat pump. This unit is a self-contained heat pump, typically installed on the roof of a building using ducts to distribute cool air to the conditioned space. It can be used in singlezone and multiple-zone applications, and can also be equipped with a constant-volume or variable-volume fan. Depending on the cooling capacity and climate, rooftop packaged DX units may be equipped with an air economizer.

Single Package Vertical Unit - A factory-installed single package heat pump which may contain cooling components. The unit is intended for exterior mounting on, adjacent interior to, or through, an outside wall. Unit major components are arranged vertically and may contain various ventilation options including ductwork. Its primary heating means shall be reverse cycle refrigeration, with secondary supplemental heating by means of electrical resistance, steam, hot water, or gas.

Split System - A split system heat pump is also known as a unitary split system heat pump. It consists of two factory-made assemblies: a condensing unit that uses outside air as the heat sink (during cooling) and heat source (during heating), and an indoor DX coil with integral

supply fan. Because the indoor unit is usually located a long distance from outside walls, it is difficult to equip a split system with an air economizer.

Water Loop Heat Pump - A water loop heat pump is a heat pump with a refrigerant-to-water heat exchanger. During cooling mode, the heat exchanger serves as the condenser, rejecting heat from the refrigerant to the water. During heating, the heat exchanger serves as the evaporator, absorbing heat from the water. The refrigerant-to-water heat exchanger is typically connected to a circulating water loop that also serves many other water loop heat pumps.

Other - Any type of heat pump, which is not described by one of the types listed above, is classified as Other.

Radiant Heater - A radiant heater is a heater that transfers heat to objects and surfaces within the heated space primarily (>50%) by infrared radiation. Radiant heaters can be direct- or indirect-fired with a heating fuel, have electric heating elements, or use hydronic coils or steam coils.

Unit Heater - A unit heater is a self-contained piece of heating equipment that requires connections only to energy sources. Unit heaters are installed in the spaces they are intended to heat and do not use ductwork to distribute heat. They are sometimes controlled in sequence with a separate air conditioner serving the same space. Unit heaters can be direct- or indirect-fired with a heating fuel, have electric heating elements, or use hydronic coils or steam coils.

Other - any other type not represented in the above choices.

Cooling Equipment Type

Field-Assembled DX System - This type is used for DX systems that are not manufactured (and rated) as single packages but rather are assembled at the building site from separately manufactured components. DX stands for direct expansion cooling. In DX cooling equipment, a refrigerant coil is placed directly in the supply air stream. As the refrigerant evaporates and expands, it removes energy, lowering the temperature of the supply air stream.

Hydronic Coil - A hydronic coil is an array of tubing, placed in a supply air stream, through which hot or cold water passes, heating or cooling the supply air stream to provide heating or air conditioning to a space. Hydronic coils, central furnaces, and DX coils are used in various configurations of heating and air-conditioning systems.

Packaged Terminal DX Unit - A packaged terminal DX air conditioner (PTAC) is a self-contained airconditioning unit typically installed through a wall. It discharges cool air directly to the space without the use of ducts for distribution. PTACs are often equipped with electric resistance heating elements and sometimes are equipped with hydronic coils or steam coils for heating.

Rooftop Package DX Unit - A rooftop packaged DX unit is also known as a unitary single-packaged air conditioner. This unit is a self-contained DX air conditioner, typically installed on the roof of a building using ducts to distribute cool air to the conditioned space. It can be used in single-zone or multiplezone applications, and can also be equipped with a constant-volume or variable-volume fan. These units are often combined, within the same assembly, with a central furnace, hydronic coils, or steam coils. Depending on the cooling capacity and climate, rooftop packaged DX units may often be equipped with an air economizer.

Single Package Vertical AC Unit - A factory-assembled single package to provide cooling with controlled temperature and dehumidification. The unit is intended for exterior mounting on, adjacent interior to, or through, an outside wall. Unit major components are arranged vertically and may contain various ventilation options including ductwork.

Split DX System - A split DX system is also known as a unitary split system air conditioner or split system. It consists of two factory-made assemblies: a condensing unit that uses outside air as the heat sink, and an indoor DX coil with integral supply fan. The indoor unit is often combined, within the same assembly, with a central furnace or hydronic coils or steam coils. Because the indoor unit is usually located a long distance from outside walls, it is difficult to equip a split system with an air economizer.

Other - any other type not represented in the above choices.

Zoning Category

Single Zone - A single-zone system serves only one thermostatic control zone. The system is usually controlled by a single thermostatic control, and only maintains comfort conditions for the space where the temperature control is located.

Multiple-Zone - A multiple-zone system is designed to meet space-conditioning loads in multiple thermostatic control zones at the same time. Multiple-zone systems usually use a common air distribution system and employ terminal units to vary the flow and temperature of air to meet the differing space-conditioning loads of each zone.

Perimeter System - A perimeter system is designed to offset only envelope heat losses and gains.

HVAC System COMcheck Inputs

Untitled.cck - COMcheck 3.9.0 Code: 90.1 (2007) Standard										
File Edit View Options Code Help										
Project Envelope Interior Lighting Exterior Lighting Mechanical										
HVAC System Plant Water Heating										
Component	System Type	Quantity	Capacity	Cap. Units	Fuel Type/ Heat Source	Condenser Type	System Details	Proposed Efficiency	Eff. Units	Minimum Efficiency
Building										
1	HVAC System 1	Heat Pump: Packaged Terminal	1							
2	Heating	Heating mode	7	kBtu/h				3.02	COP	3.02 COP
3	Cooling	Cooling mode	7	kBtu/h				10.81	EER	10.81 EER

Equipment Capacity - Enter the cooling capacity range for the cooling equipment selected and the heating capacity for the heating equipment selected.

Fuel Type/Heat Source - Select the Fuel Type, the Heat Source, and provide the Equipment Capacity for the heating equipment. If you select Hydronic or Steam Coil as the Heating Equipment Type, select the Heat Source for this equipment. If you select Central Furnace or Duct Furnace, select the Fuel Type for this equipment. If you select Radiant Heater or Unit Heater, you may choose from either the Fuel Type or Heat Source options.

Condenser Type - The condenser of an air conditioner is where refrigerant rejects heat absorbed during the process of cooling indoor spaces. As the refrigerant passes through the heat exchanger it

rejects heat to the surrounding fluid, usually air or water. If the equipment is a heat pump, the condenser becomes an evaporator during heating mode. As the refrigerant passes through the heat exchanger, it absorbs heat from the surrounding fluid, causing the refrigerant to change from a liquid to a gas (or evaporate).

Air Cooled - An air-cooled condenser is a refrigerant-to-air heat exchanger exposed to outdoor conditions. As refrigerant passes through the coils of the heat exchanger, heat is rejected to outdoor air (during cooling) and absorbed from outdoor air (during heating).

Evaporatively Cooled - An evaporatively-cooled condenser is similar to an air-cooled condenser with the exception that during cooling, the heat exchanger is sprayed with water, increasing the heat rejection. Heat pumps and air conditioners equipped with evaporatively cooled condensers are typically more efficient than their air-cooled counterparts.

Groundwater Coupled - A groundwater-coupled condenser is similar to a water-cooled condenser except that groundwater will always be the heat source (or sink) for the condenser. As refrigerant passes through the coils of the heat exchanger, heat is rejected to groundwater (during cooling) and absorbed from groundwater (during heating).

Water Heating System

The Water Heating button enables you to enter the service water heating system(s) in your building. Water heater types allowed are Storage Water Heaters or Instantaneous Water Heaters. Storage Water Heater refers to a water heater that heats and stores water within the water heater for delivery on demand and has an input rating of less than 4,000 Btu/hour per gallon of stored water. Instantaneous Water Heater means a water heater that has an input rating equal to or greater than 4,000 Btu/hour per gallon of stored water.

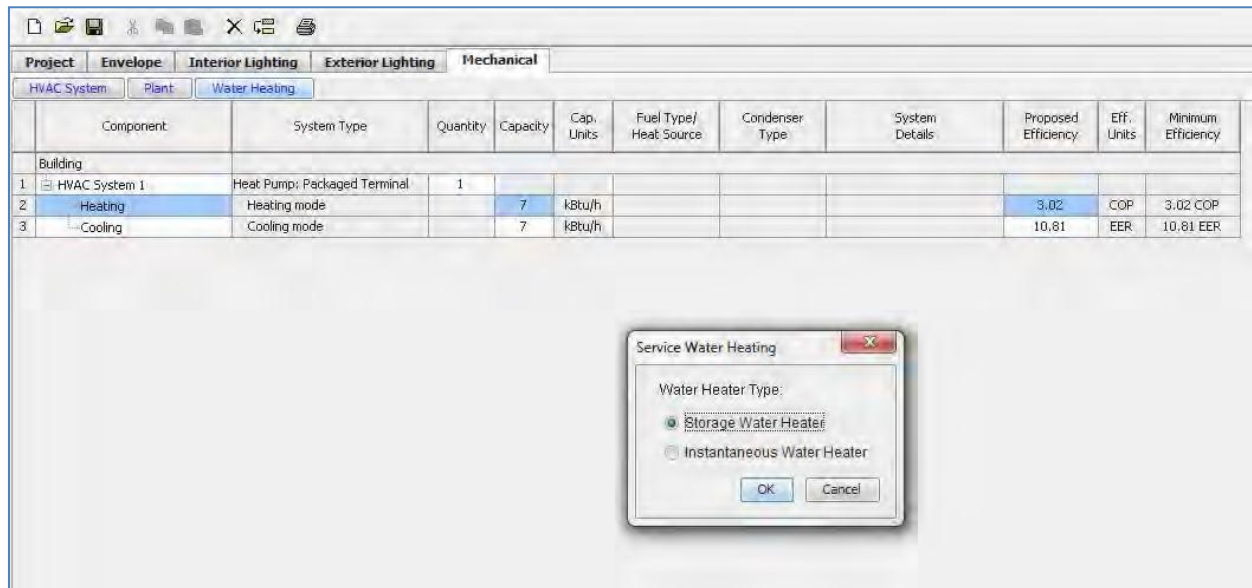

Where multiple different water heating systems are present within the building, you may select the Water Heating button multiple times to enter more than one system. Where multiple identical (or nearly identical) systems are present, describe them once and use the Quantity field to indicate the number present.

Service Water Heating COMcheck Inputs

Component	System Type	Quantity	Capacity	Cap. Units	Fuel Type/Heat Source	Condenser Type	System Details	Proposed Efficiency	Eff. Units	Minimum Efficiency
Building										
1	HVAC System 1	Heat Pump: Packaged Terminal	1							
2	Heating	Heating mode	7	kBtu/h				3.02	COP	3.02 COP
3	Cooling	Cooling mode	7	kBtu/h				10.81	EER	10.81 EER
4	Water Heater 1	Storage Water Heater	1	50	Gallons	Gas	Circulation Pump	0.53	EF	0.53 EF

Equipment Capacity - Equipment Capacity refers to the rated storage volume of the water heater in gallons.

Fuel Type/Heat Source - Fuel Type/Heat Source refers to the principle water heater fuel source. Options shown are Electricity, Natural Gas (including propane), and Oil.

System Details - Checkboxes are provided to allow more details to be noted.

System Has a Circulation Pump - A circulation pump is used in a service water heating system served by a continuous water loop. The circulation pump is controlled to circulate hot water from the water heating equipment as necessary to maintain a certain hot water temperature at all times in the circulation loop.

Heat Trace Tape Installed in the System - Heat trace tape is tape with embedded electric resistance heating elements. Heat trace tape is adhered to hot water piping. It is energized as necessary to deliver hot water at the desired temperature.

Heated Swimming Pool System - If a heated swimming pool exists in the building, this box should be checked.

Combined Space/SWH System - Check this box if the same heating equipment is used to serve both hydronic space heating as well as service water heating needs.

Input Rating - The Input Rating is the rated fuel input of the water heater in Btu/hour. The rated input is typically shown on the nameplate of the water heater. Inputs are required only for water heaters using gas or oil fuel types.



Mechanical Compliance Certificate

Print a Mechanical Compliance Certificate when all HVAC and heating equipment inputs are complete. Click on the File menu and choose View / Print Report. Check or indicate Not Applicable for every item under Section 4: Requirements Checklist and sign/date under Section 5: Compliance Statement and Section 6: Post Construction Compliance Statement.

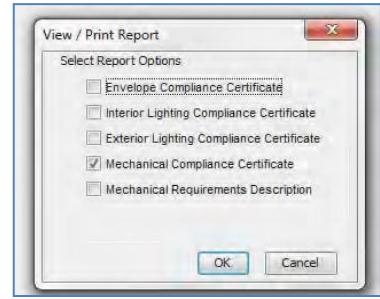

Sample Mechanical Compliance Certificate



COMcheck Software Version 3.9.0

Mechanical Compliance Certificate**90.1 (2007) Standard****Section 1: Project Information**Project Type: **New Construction**

Project Title : Sample Project

Construction Site:
1000 Peachtree Street
Atlanta, GA 30308Owner/Agent:
Joe OwnerDesigner/Contractor:
Joe Contractor**Section 2: General Information**Building Location (for weather data): **Atlanta, Georgia**
Climate Zone: **3a****Section 3: Mechanical Systems List**

Quantity	System Type & Description
1	HVAC System 1 (Single Zone) : Packaged Terminal Heat Pump Heating Mode: Capacity = 7 kBtu/h, Efficiency = 3.02 COP Cooling Mode: Capacity = 7 kBtu/h, Efficiency = 10.81 EER.
1	Water Heater 1: Gas Storage Water Heater, Capacity: 50 gallons, Input Rating: 75 Btu/h w/ Circulation Pump, Efficiency: 0.53 EF

Section 4: Requirements Checklist**Requirements Specific To: HVAC System 1 :**

1. Equipment minimum efficiency: Heat Pump: 3.02 COP 10.81 EER
- N/A* 2. VAV fans with static pressure sensors are placed in a position such that the controller setpoint is no greater than one-third the total design fan static pressure. If placement results in the sensor being located downstream of major duct splits, multiple sensors are installed in each major branch.
Exception(s):
 Systems with DDC of individual zone boxes reporting to the central control panel and reset of static pressure setpoint based on the zone requiring the most pressure.
- N/A* 3. Systems with DDC of individual zone boxes reporting to the central control panel has static pressure setpoint reset based on the zone requiring the most pressure.

Requirements Specific To: Water Heater 1 :

1. Water heating equipment meets ASHRAE 90.1-1999 minimum efficiency requirements: Gas Storage Water Heater efficiency: 0.53 EF
2. Hot water system sized per manufacturer's sizing guide
3. All piping in circulating system insulated
4. Hot water storage temperature adjustable down to 120°F or lower
5. Automatic time control of heat tapes and recirculating systems present
6. Controls will shut off operation of circulating pump between water heater/boiler and storage tanks within 5 minutes after end of heating cycle.

Generic Requirements: Must be met by all systems to which the requirement is applicable:

1. Hot water pipe insulation: 1 in. for pipes <=1.5 in. and 2 in. for pipes >1.5 in.
Chilled water/refrigerant/brine pipe insulation: 1 in. for pipes <=1.5 in. and 1.5 in. for pipes >1.5 in.
Steam pipe insulation: 1.5 in. for pipes <=1.5 in. and 3 in. for pipes >1.5 in.

Project Title: Sample Project
Data filename: Untitled.cckReport date: 11/22/11
Page 1 of 3

Sample Mechanical Compliance Certificate

Exception(s):

- Piping within HVAC equipment.
- Fluid temperatures between 60 and 105°F.
- Fluid not heated or cooled.
- Runouts <4 ft in length.
- Pipe unions in heating systems.

2. Piping, insulated to 1/2 in. if nominal diameter of pipe is <1.5 in.;
Larger pipe insulated to 1 in. thickness

3. Lavatory faucet outlet temperatures in public restrooms limited to 110°F (43°C)

4. Load calculations per acceptable engineering standards and handbooks

5. Thermostatic controls have 5°F deadband

Exception(s):

- Thermostats requiring manual changeover between heating and cooling
- Special occupancy or special applications where wide temperature ranges are not acceptable and are approved by the authority having jurisdiction.

N/A 6. Demand control ventilation (DCV) present for high design occupancy areas (>40 person/1000 ft² in spaces >500 ft²) and served by systems with any one of 1) an air-side economizer, 2) automatic modulating control of the outdoor air damper, or 3) a design outdoor airflow greater than 3000 cfm.

Exception(s):

- Systems with heat recovery.
- Multiple-zone systems without DDC of individual zones communicating with a central control panel.
- Systems with a design outdoor airflow less than 1200 cfm.
- Spaces where the supply airflow rate minus any makeup or outgoing transfer air requirement is less than 1200 cfm.

N/A 7. Where separate thermostats are used for heating and cooling, acceptable measures are used to prevent simultaneous heating and cooling

N/A 8. Stair and elevator shaft vents are equipped with motorized dampers

Exception(s):

- Ventilation systems serving unconditioned spaces.
- Gravity (non-motorized) dampers are acceptable in buildings less than three stories in height above grade.

9. Acceptable measures used to prevent simultaneous humidification and dehumidification

Exception(s):

- Desiccant systems and systems for uses requiring specific humidity levels (approval required)

N/A 10. Automatic controls for freeze protection systems present

11. Duct, plenum, and piping insulation surfaces suitably protected from weather, moisture, or likely damage

12. Duct Sealing:

- a) Pressure sensitive tape used as the primary sealant is certified to comply with UL-181A or UL-181B,
- b) longitudinal and transverse seams for ducts in unconditioned spaces,
- c) longitudinal and transverse seams and duct wall penetrations for ducts outside the building,
- d) transverse seams on buried ducts

13. Motorized, automatic shutoff dampers required on exhaust and outdoor air supply openings

Exception(s):

- Gravity dampers acceptable in buildings <3 stories
- Gravity dampers acceptable in systems with outside or exhaust air flow rates less than 300 cfm where dampers are interlocked with fan

14. R-6 for supply air ducts located outside the building, in ventilated attics and in unvented attic above insulated ceiling
R-3.5 for supply air ducts in unvented attic with roof insulation, unconditioned and underground spaces
R-3.5 for return air ducts located outside the building, in ventilated attics and in unvented attic above insulated ceiling

15. Humidistat controls prevent reheating, recooling, and mixing of mechanically heated air with mechanically cooled air

Exception(s):

- Capability of first reducing supply air volume 50% or less of the design rate or minimum outdoor air ventilation, or per regulatory standard, whichever is larger, before combined heating/cooling occurs.
- Cooling capacity <80 kBtu/h and capability to unload cooling equipment.
- Cooling capacity <40 kBtu/h.
- Rigid humidity requirements.
- Site-recovered or site-solar energy sources or,
- Use of a desiccant systems.

N/A 16. Kitchen hoods >5,000 cfm provided with 50% makeup air that is uncooled and heated to no more than 60°F unless specifically exempted

Project Title: Sample Project
Data filename: Untitled.cck

Report date: 11/22/11
Page 2 of 3

Sample Mechanical Compliance Certificate

Sample Mechanical Compliance Certificate

Exception(s):

- Where hoods are used to exhaust ventilation air that would otherwise exfiltrate or be exhausted by other fan systems.
- Certified grease extractor hoods that require a face velocity no >60 fpm.
- N/A 17. Buildings with fume hood systems having an exhaust rate > 15,000 cfm has at least one of the following features:
 - a) VAV hood exhaust and room supply systems capable of reducing exhaust and makeup air volume to 50% or less of design values
 - b) Direct makeup air supply equal to at least 75% of the exhaust rate, heated no warmer than 2°F below room setpoint, cooled to no cooler than 3°F above room setpoint, no humidification added, and no simultaneous heating and cooling used for dehumidification control.
 - c) Heat recovery systems to precondition makeup air from fume hood exhaust.

- N/A 18. Exhaust air heat recovery included for systems 5,000 cfm or greater with more than 70% outside air fraction or specifically exempted.

Exception(s):

- Laboratory fume hood systems with a total exhaust rate <= 5000 cfm.
- Systems serving spaces that are not cooled and heated to <60°F
- Systems with more than 60% of the outdoor heating energy is provided from site-recovered or site solar energy.
- Systems exhausting toxic, flammable, paint, or corrosive fumes or dust.
- Commercial kitchen hoods.
- Systems requiring dehumidification with cooling coil energy recovery in series with the cooling coil.
- Where the largest exhaust source is less than 75% of the design outdoor airflow.
- Heating energy recovery.
- 19. All service water heating requirements are listed in requirements section specific to the system.

Section 5: Compliance Statement

Compliance Statement: The proposed mechanical design represented in this document is consistent with the building plans, specifications and other calculations submitted with this permit application. The proposed mechanical systems have been designed to meet the 90.1 (2007) Standard requirements in COMcheck Version 3.9.0 and to comply with the mandatory requirements in the Requirements Checklist.

Joe Mechanical – Mechanical Designer
Name - Title

Joe Mechanical
Signature

11/22/11
Date

Section 6: Post Construction Compliance Statement

- HVAC record drawings of the actual installation and performance data for each equipment provided to the owner within 90 days after system acceptance.
- HVAC O&M documents for all mechanical equipment and system provided to the owner within 90 days after system acceptance.
- Written HVAC balancing report provided to the owner.

The above post construction requirements have been completed.

Joe Mechanical
Principal Mechanical Designer-Name

Joe Mechanical
Signature

11/22/11
Date

Sample Mechanical Compliance Certificate

THIS PAGE LEFT INTENTIONALLY BLANK

Appendix D: COMcheck Interior and Exterior Lighting

Use *COMcheck* to demonstrate that the interior and exterior lighting complies with ASHRAE Standard 90.1-2007.

Lighting Screens

Use the buttons at the top of the screen to create a list of lighting fixtures present in your proposed design. Each fixture type you select is added to the lighting fixtures list displayed on the screen. For

each fixture type, you must enter a ballast type (if applicable), the number of lamps per fixture, quantity, and the fixture input wattage. Input wattage is the electrical power input to the lamp and ballast combination.

After entering complete information for each new fixture, the software automatically updates the compliance results once you hit the Enter key or click in another cell. The results are displayed at the bottom of the screen in the compliance box. If TBD (to be determined) is displayed in this field, you most likely have not yet filled in the fixture wattage or quantity for one or more components. To determine which data are missing or invalid, look for fields with white-on-red text. In addition to providing inputs for all white-on-red fields, you must select at least one building use type and its corresponding area on the Project screen before the software can determine compliance.

Interior Lighting Screen

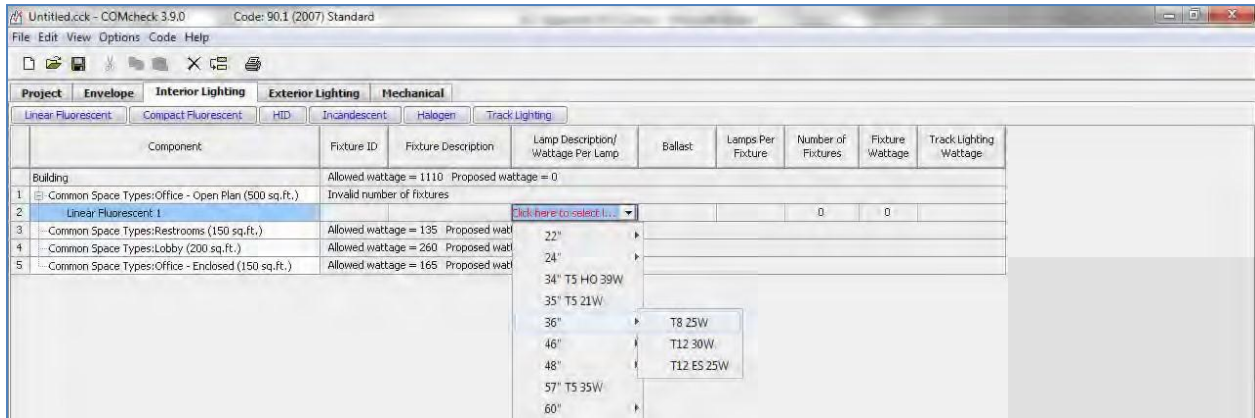

Exterior Lighting Screen

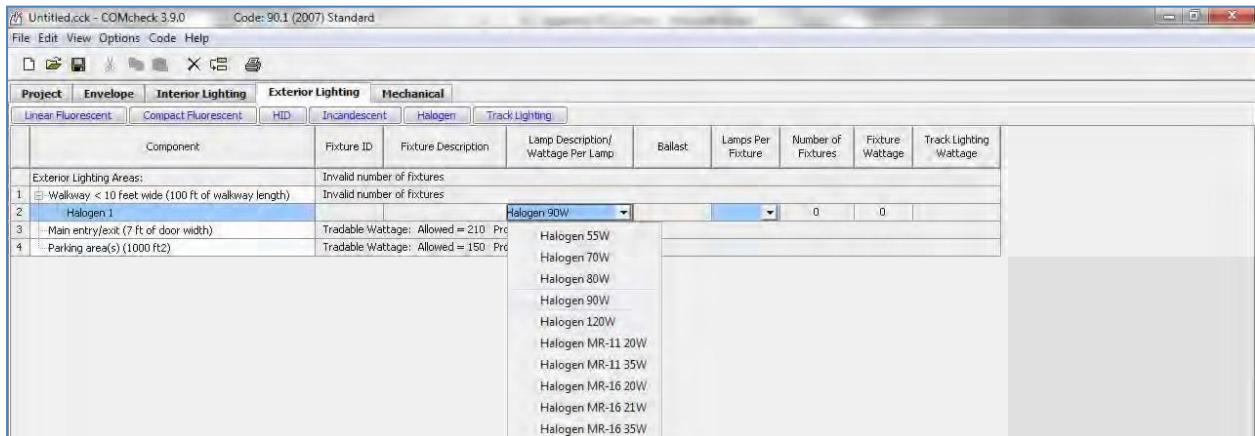

Lighting Screen Inputs

Component	Fixture ID	Fixture Description	Lamp Description/ Wattage Per Lamp	Ballast	Lamps Per Fixture	Number of Fixtures	Fixture Wattage	Track Lighting Wattage
Building								
1 Common Space Types:Office - Open Plan (500 sq.ft.)								
2 Linear Fluorescent 1			36" T8 25W	Electronic	3	6	75	
3 Common Space Types:Restrooms (150 sq.ft.)								
4 Linear Fluorescent 2			36" T8 25W	Electronic	3	1	75	
5 Common Space Types:Lobby (200 sq.ft.)								
6 Incandescent 1			Incandescent 60W		1	5	60	
7 Common Space Types:Office - Enclosed (150 sq.ft.)								
8 Linear Fluorescent 3			36" T8 25W	Electronic	3	2	75	

Fixture ID - The Fixture ID field shows the fixture ID you have entered. You can associate the fixture with a fixture type designation used on the lighting fixture schedule and elsewhere in the construction documents; e.g., F1 for fixture type 1. Fixture ID is an optional field that you may leave blank, but it is recommended as it enables fixtures to be clearly defined.

Fixture Description - The Fixture Description field is for descriptions of fixtures that you enter. Fixture Description is an optional field that you may leave blank. However, fixture descriptions can help you keep track of the fixtures in the list, avoid errors and oversights, and facilitate plan review and inspections because this information is included on the compliance certificate. Fixture descriptions may include manufacturer and part number, dimensions (e.g., 2x4), mounting type (e.g., recessed, surface, suspended), or other distinguishing characteristics.

Lamp Description/Wattage Per Lamp - Click the left mouse button in the Lamp Description/Wattage Per Lamp field to select from a drop-down list of available lamp types. The drop-down list contains the most commonly used lamp and ballast combinations. Select Other if the lamp type you intend to use does not match one of the listed types.

Ballast - The ballast type is entered by selecting from a drop-down list. (Incandescent and halogen fixtures do not require a ballast entry.) Available ballast types are magnetic, electronic, premium efficiency, standard, and pulse start. The following definitions have been used in determining default input wattages. You should use these definitions in describing the ballast type in the fixtures you intend to use.

Magnetic - applies to CFL and linear fluorescent; the standard CFL or linear fluorescent ballast that incorporates large inductive components and operates around 60 Hz.

Electronic - applies to CFL and linear fluorescent; a CFL or linear fluorescent ballast comprised of electronic and semiconductor components with only very small inductive components that operates at high frequencies in the 20-40 Hz range.

Premium Efficiency - applies to 4 foot T8 linear fluorescent; a linear 4-foot T8 instant-start, programmed-start, or dimmable NEMA BL2 rated high frequency electronic ballast that exhibits high efficiency in the 88-96 lumen/watt range.

Standard - applies to all HID High intensity discharge. Generic term describing mercury vapor, metal halide, high pressure sodium, and (informally) low pressure sodium light sources and

luminaires; a standard High Intensity Discharge (HID) ballast not incorporating Pulse-start technology.

Pulse Start - applies to Metal Halide (MH) and Ceramic Metal Halide (CMH); a ballast that uses an igniter in place of an additional probe for starting an MH or CMH lamp.

Lamps Per Fixture - Enter the number of lamps per fixture.

Number of Fixtures - Enter the number of fixtures.

Fixture Wattage - Enter the fixture wattage.

You can enter the fixture wattage directly or have the software provide a typical wattage for that fixture. To input a typical wattage, click in the cell and then click the right mouse button in the Fixture Wattage field to display the pop-up context menu. The software will provide a typical input wattage for the fixture. Not all possible lamp and ballast combinations are included-only those for which adequate data were available. If the Use Default option is gray, a typical wattage is not available. Input wattage is the related electrical power input to the lamp and ballast combination.

You may either use the typical input wattage provided by the software or override it with a value based on the equipment you intend to install. In either case, you should be prepared to provide supporting documentation based on manufacturer's literature to the building department.

Track Lighting Wattage - Select the criteria and provide associated inputs.

Interior and Exterior Lighting Compliance Certificates

Print Lighting Compliance Certificates when lighting is entered and inputs are complete. Click on the File menu and choose View / Print Report.

Check or indicate Not Applicable for every item under Section 4: Requirements Checklist and sign/date under Section 5: Compliance Statement and Section 6: Post Construction Compliance Statement.



Sample Interior Lighting and Power Compliance Certificate



COMcheck Software Version 3.9.0
**Interior Lighting and Power
 Compliance Certificate**

90.1 (2007) Standard

Section 1: Project Information

Project Type: **New Construction**
 Project Title : Sample Project

Construction Site: 1000 Peachtree Street Atlanta, GA 30308	Owner/Agent: Joe Owner	Designer/Contractor: Joe Contractor
--	---------------------------	--

Section 2: Interior Lighting and Power Calculation

A Area Category	B Floor Area (ft ²)	C Allowed Watts / ft ²	D Allowed Watts (B x C)
Common Space Types:Office - Open Plan	500	1.1	550
Common Space Types:Restrooms	150	0.9	135
Common Space Types:Lobby	200	1.3	260
Common Space Types:Office - Enclosed	150	1.1	165
Total Allowed Watts =			1110

Section 3: Interior Lighting Fixture Schedule

A Fixture ID : Description / Lamp / Wattage Per Lamp / Ballast	B Lamps/ Fixture	C # of Fixtures	D Fixture Watt.	E (C X D)
Common Space Types:Office - Open Plan (500 sq.ft.) Linear Fluorescent 1: 36" T8 25W / Electronic	3	6	75	450
Common Space Types:Restrooms (150 sq.ft.) Linear Fluorescent 2: 36" T8 25W / Electronic	3	1	75	75
Common Space Types:Lobby (200 sq.ft.) Incandescent 1: Incandescent 60W	1	5	60	300
Common Space Types:Office - Enclosed (150 sq.ft.) Linear Fluorescent 3: 36" T8 25W / Electronic	3	2	75	150
Total Proposed Watts =				975

Section 4: Requirements Checklist

Lighting Wattage:

1. Total proposed watts must be less than or equal to total allowed watts.

Allowed Watts	Proposed Watts	Complies
1110	975	YES

2. Exit signs 5 Watts or less per sign.

Controls, Switching, and Wiring:

3. Independent manual or occupancy sensing controls for each space (remote switch with indicator allowed for safety or security).
 4. Occupant sensing control in class rooms, conference/meeting rooms, and employee lunch and break rooms.

Exceptions:

- Spaces with multi-scene control; shop classrooms, laboratory classrooms, and preschool through 12th grade classrooms.

Project Title: Sample Project
 Data filename: Untitled.cck

Report date: 11/22/11
 Page 1 of

Sample Interior Lighting and Power Compliance Certificate

N/A 5. Automatic shutoff control for lighting in >5000 sq.ft buildings by time-of-day device, occupant sensor, or other automatic control.

Exceptions:

24 hour operation lighting; patient care areas; where auto shutoff would endanger safety or security.

N/A 6. Master switch at entry to hotel/motel guest room.

N/A 7. Separate control device for display/accent lighting, case lighting, task lighting, nonvisual lighting, lighting for sale, and demonstration lighting.

8. Tandem wired one-lamp and three-lamp ballasted luminaires (No single-lamp ballasts)

Exceptions:

Electronic high-frequency ballasts.

Luminaires not on same switch.

Recessed luminaires 10 ft. apart or surface/pendant not continuous.

Luminaires on emergency circuits.

Voltage Drop:

9. Feeder conductors have been designed for a maximum voltage drop of 2 percent.

10. Branch circuit conductors have been designed for a maximum voltage drop of 3 percent.

Interior Lighting **PASSES**. Design 1.2% better than code.

Section 5: Compliance Statement

Compliance Statement: The proposed lighting design represented in this document is consistent with the building plans, specifications and other calculations submitted with this permit application. The proposed lighting system has been designed to meet the 90.1 (2007) Standard requirements in COMcheck Version 3.9.0 and to comply with the mandatory requirements in the Requirements Checklist.

Joe Contractor - GC
Name - Title

Joe Contractor
Signature

11/22/11
Date

Section 5: Post Construction Compliance Statement

Record Drawings and Operating and Maintenance Manuals:

1. Construction documents with record drawings and operating and maintenance manuals provided to the owner.

Joe Contractor
Lighting Designer or Contractor Name

Joe Contractor
Signature

11/22/11
Date

Exterior Lighting Compliance Certificate



COMcheck Software Version 3.9.0
Exterior Lighting Compliance Certificate

90.1 (2007) Standard

Section 1: Project Information

Project Type: **New Construction**
 Project Title : Sample Project

Construction Site: 1000 Peachtree Street Atlanta, GA 30308	Owner/Agent: Joe Owner	Designer/Contractor: Joe Contractor
--	---------------------------	--

Section 2: Exterior Lighting Area/Surface Power Calculation

A Exterior Area/Surface	B Quantity	C Allowed Watts / Unit	D Tradable Wattage	E Allowed Watts (B x C)	F Proposed Watts
Walkway < 10 feet wide	100 ft of walkway length	1	Yes	100	140
Main entry/exit	7 ft of door width	30	Yes	210	180
Parking area(s)	1000 ft2	0.15	Yes	150	100
Total Tradable Watts* =				460	420
Total Allowed Watts =				460	
Total Allowed Supplemental Watts** =				23	

* Wattage tradeoffs are only allowed between tradable areas/surfaces.
 ** A supplemental allowance equal to 5% of total allowed wattage may be applied toward compliance of both non-tradable and tradable areas/surfaces.

Section 3: Exterior Lighting Fixture Schedule

A Fixture ID : Description / Lamp / Wattage Per Lamp / Ballast	B Lamps/ Fixture	C # of Fixtures	D Fixture Watt.	E (C X D)
Walkway < 10 feet wide (100 ft of walkway length): Tradable Wattage				
HID 1: High-Pressure Sodium 70W / Standard	1	2	70	140
Main entry/exit (7 ft of door width): Tradable Wattage				
Halogen 1: Halogen 90W	1	2	90	180
Parking area(s) (1000 ft2): Tradable Wattage				
HID 2: Metal Halide 100W / Standard	1	1	100	100
Total Tradable Proposed Watts =				420

Section 4: Requirements Checklist

Lighting Wattage:
 1. Within each non-tradable area/surface, total proposed watts must be less than or equal to total allowed watts. Across all tradable areas/surfaces, total proposed watts must be less than or equal to total allowed watts.

Compliance: Passes.

Controls, Switching, and Wiring:
 2. All exemption claims are associated with fixtures that have a control device independent of the control of the nonexempt lighting.
 3. All lighting fixtures are controlled by a photosensor or astronomical time switch that is capable of automatically turning off the fixture when sufficient daylight is available or the lighting is not required.

Project Title:
 Data filename: Untitled.cck

Report date:
 Page 1 of 2

Sample Exterior Lighting Compliance Certificate

Exceptions:

- Covered vehicle entrance/exit areas requiring lighting for safety, security and eye adaptation.

Exterior Lighting Efficacy:

- 4. All exterior building grounds luminaires that operate at greater than 100W have minimum efficacy of 60 lumen/watt.

Exceptions:

- Lighting that has been claimed as exempt and is identified as such in Section 3 table above.
- Lighting that is specifically designated as required by a health or life safety statute, ordinance, or regulation.
- Emergency lighting that is automatically off during normal building operation.
- Lighting that is controlled by motion sensor.

Exterior Lighting PASSES. Design 13% better than code.

Section 5: Compliance Statement

Compliance Statement: The proposed exterior lighting design represented in this document is consistent with the building plans, specifications and other calculations submitted with this permit application. The proposed lighting system has been designed to meet the 90.1 (2007) Standard requirements in COMcheck Version 3.9.0 and to comply with the mandatory requirements in the Requirements Checklist.

Joe Contractor - GC
Name - Title

Joe Contractor
Signature

11/22/11
Date

Section 5: Post Construction Compliance Statement

Record Drawings and Operating and Maintenance Manuals:

- 1. Construction documents with record drawings and operating and maintenance manuals provided to the owner.

Joe Contractor
Lighting Designer or Contractor Name

Joe Contractor
Signature

11/22/11
Date

THIS PAGE LEFT INTENTIONALLY BLANK

Appendix E: Prescriptive Outside Air Requirements

Projects using the prescriptive approach to outside air requirements must introduce outside air based on space type and square footage. The table below lists outside air CFM requirements per space type.

Prescriptive Outside Air Requirements

Space Type	cfm/sf
Educational Facilities	
Daycare (through age 4)	0.43
Daycare sickroom	0.43
Classrooms (ages 5–8)	0.38
Classrooms (age 9 plus)	0.46
Lecture classroom	0.52
Lecture hall (fixed seats)	1.20
Art classroom	0.38
Science laboratories	0.43
University/college laboratories	0.43
Wood/metal shop	0.38
Computer lab	0.38
Media center	0.38
Music/theater/dance	0.42
Multi-use assembly	0.80
Food and Beverage Service	
Restaurant dining rooms	0.70
Cafeteria/fast-food dining	0.90
Bars, cocktail lounges	0.90
General	
Break rooms	0.25
Coffee stations	0.22
Conference/meeting	0.30
Corridors	0.06
Storage rooms	0.12
Miscellaneous Spaces	
Bank vaults/safe deposit	0.09
Computer (not printing)	0.08
Electrical equipment rooms	0.06
Elevator machine rooms	0.12
Pharmacy (prep. area)	0.23

Space Type	cfm/sf
Office Buildings	
Office space	0.09
Reception areas	0.21
Telephone/data entry	0.36
Main entry lobbies	0.11
Public Assembly Spaces	
Auditorium seating area	0.75
Places of religious worship	0.72
Courtrooms	0.42
Legislative chambers	0.3
Libraries	0.17
Lobbies	0.75
Museums (children's)	0.44
Museums/galleries	0.36
Retail	
Sales (except as below)	0.24
Mall common areas	0.36
Barbershop	0.25
Beauty and nail salons	0.625
Pet shops (animal areas)	0.26
Supermarket	0.12
Coin-operated laundries	0.22
Sports and Entertainment	
Sports arena (play area)	0.30
Gym, stadium (play area)	0.30
Spectator areas	1.20
Swimming (pool & deck)	0.48
Disco/dance floors	2.10
Health club/aerobics room	0.88
Health club/weight rooms	0.26
Bowling alley (seating)	0.52

Photo studios	0.17
Shipping/receiving	0.12
Transportation waiting	0.80
Warehouses	0.06

Gambling casinos	1.08
Game arcades	0.34
Stages, studios	0.77

THIS PAGE LEFT INTENTIONALLY BLANK

Appendix F: Insulation Grading

Grade I - A "Grade I" installation is achieved by completely filling the cavity with insulation, from topto-bottom and side-to-side without voids or compression. Tightly fit insulation around wiring, and other obstructions, such as blocking or bridging and avoid compression. Most spray applied insulation can achieve this grading provide depth of the cavity is filled.

Grade II - A "Grade II" installation may have small defects, such as gaps around wiring, electrical outlets, plumbing and other obstructions. There may also be some compression. Grade II is determined by any one or combination of the following: gaps and spaces running clear through the insulation amounting to more than 2%; an incomplete cavity fill of over 10%; over 30% compression.

Grade III - A "Grade III" installation will not pass ECLC inspection. This application has substantial gaps or voids, compression in many areas and/or is not in constant contact with the air barrier.

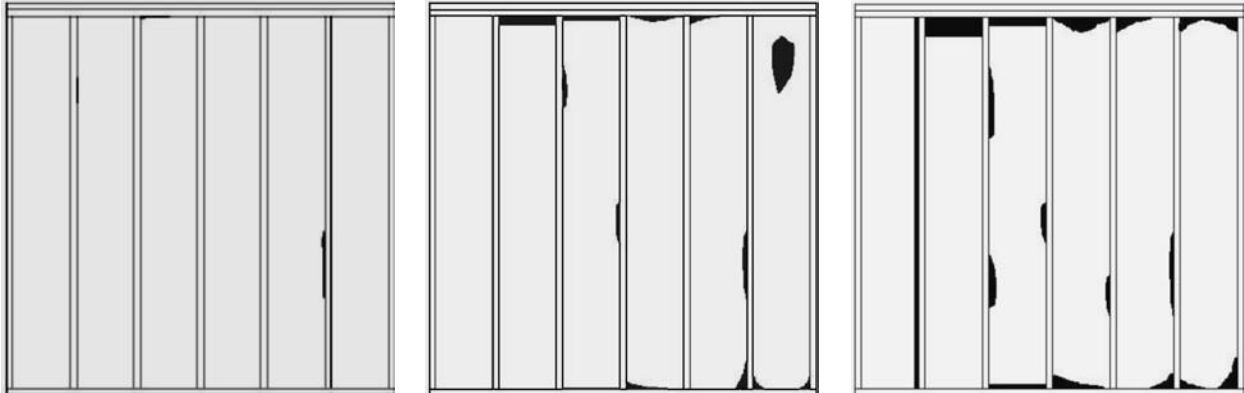

GRADE I

GRADE II

GRADE III

For projects that receive a Grade III on inspection, the ECLC Technical Advisor will provide a list of areas that need to be addressed and photos must be supplied that demonstrate compliance.

THIS PAGE LEFT INTENTIONALLY BLANK

Glossary

A

American with Disabilities Act (ADA)

A wide-ranging civil rights law that prohibits, under certain circumstances, discrimination based on disability.

Annual Fuel Utilization Efficiency (AFUE)

Thermal efficiency measure of combustion equipment like furnaces, boilers, and water heaters.

Air Change

Replacement of the entire indoor air volume of a building with outside air.

Annual Plant

A plant that usually germinates, flowers, and dies in a year or season.

B

Building Envelope

The physical separator between the interior and the exterior environments of a building. Not necessarily the same as the Building Thermal Envelope.

Building Envelope Floor Area

The gross square footage of floor at ground-level plus all cantilevered areas that separate conditioned from unconditioned space.

Building Thermal Envelope

The portion of the building envelope that is comprised of the continuous air barrier and insulation and separates conditioned space from unconditioned space.

Brownfield

Property that has the presence or potential presence of a hazardous substance, pollutant, or contaminant.

C

CFM₂₅ (Cubic Feet per Minute at 25 Pa)

The volume flow rate of air in cubic feet per minute moved through a duct when pressurized to 25 Pascals.

CFM₇₅ (Cubic Feet per Minute at 75 Pa)

The volume of air in cubic feet per minute moved through a fan that is set to a 75 Pascal pressure differential between conditioned and unconditioned space.

Chlorofluorocarbon (CFC)

An organic compound that contains carbon, chlorine, and fluorine, produced as a volatile derivative of methane and ethane. The manufacture of such compounds has been phased out by the Montreal Protocol because they contribute to ozone depletion.

COMcheck

A commercial energy code compliance software developed by Pacific Northwest National Laboratory for the U.S. Department of Energy's Office of Codes and Standards. COMcheck can be downloaded free of charge at www.energycodes.gov.

Continuous Air Barrier

The combination of primary air barrier materials that make up the portion of the building envelope that provides overall airtightness of the building and separates conditioned and unconditioned space.

Continuously Occupied Spaces

Spaces that are used 4 hours or more a day on a regular basis, such as private offices, open offices, classrooms, reception/ lobby areas.

Coefficient of Performance - Cooling (COP_C)

The ratio of the rate of heat removal to the rate of energy input, in consistent units, for a complete refrigerating system or some specific portion of that system under designated operating conditions.

Coefficient of Performance – Heat Pump (COP_H)

The ratio of the rate of heat delivered to the rate of energy input, in consistent units, for a complete heat pump system, including the compressor and, if applicable, auxiliary heat, under designated operating conditions.

Curfew Lighting

The concept of reducing the amount of lighting during certain portions of the night.

D**Daylit Floor Areas**

Areas naturally lit by top or side glazing. For vertical glazing, the daylit floor area is calculated by adding 2 feet to either side of the wall containing the window and projecting 15 feet into the space. For top glazing, the daylit floor area is the footprint of the skylight + 70% of the ceiling height added to each side of the footprint. Daylit floor area terminates at full-height vertical partitions.

Demand Control Ventilation (DCV)

A ventilation system capability that provides for the automatic reduction of outdoor air intake below design rates when the actual occupancy of spaces served by the system is less than design occupancy.

Dedicated Outdoor Air System (DOAS)

A system that pre-conditions the outside air which is then supplied to the main HVAC systems in the building.

Desuperheater

A small, auxiliary heat exchanger that uses superheated gases from a heat pump's compressor to heat water.

E**Electronic Expansion Valve (EXV)**

A valve is controlled by an electronic circuit which is often designed to allow the valve to control some aspect of system operation in addition to superheat at the outlet of the evaporator.

Electronically Commutated Motors (ECM's)

A high efficiency programmable brushless DC motor utilizing a permanent magnet rotor and a built-in inverter. DC motors are significantly more energy efficient than AC motors and much easier to control.

ELR₇₅ (Envelope Leakage Ratio at 75 Pa)

The Envelope Leakage Ratio (ELR) is the quantity of air leakage expressed in cubic feet per minute at a 75 Pascal pressure difference (CFM₇₅) divided by the total square footage of the building's thermal envelope (SFBE).

Energy Efficiency Ratio (EER)

The ratio of net cooling capacity in Btu/h to total rate of electric input in watts under designated operating conditions.

Energy Factor

A measure of water heater overall efficiency.

Envelope Wall Area

The gross square footage of the building exterior walls that separate conditioned from unconditioned space.

F**Full Cutoff**

A luminaire light distribution where zero candela intensity occurs at or above an angle of 90 degrees above nadir. Additionally the candela per 1000 lamp lumens does not numerically exceed 100 (10 percent) at or above a vertical angle of 80 degrees above nadir. This applies to all lateral angles around the luminaire.

G**Greenspace**

A protected open space maintained in a natural, undisturbed or revegetated condition.

Greywater

Wastewater generated from domestic activities such as laundry, dishwashing, and bathing, which can be recycled on-site for uses such as landscape irrigation and constructed wetlands. Greywater differs from water from the toilets which is designated sewage or blackwater to indicate it contains human waste.

Gross Floor Area

The sum total square footage of each floor area (calculated from the wall sheathing inward) within the building envelope. Exclude non-enclosed spaces, such as covered walkways, porches, and garage areas.

H**Hydrochlorofluorocarbon (HCFC)**

An organic compound that contains hydrogen, carbon, chlorine, and fluorine, produced as a volatile derivative of methane and ethane. The manufacture of such compounds has been phased out by the Montreal Protocol because they contribute to ozone depletion.

Heat Island Effect

The heat island effect is a temperature phenomenon in which heat-absorbing buildings, especially those with dark roofs and non-reflective surfaces, release heat absorbed from sunlight into the surrounding atmosphere. The resulting effect is an increase in outdoor air temperature in a specific area, or "island." Increases in local air temperature caused by the heat island effect generally occur in urban areas and centers where many buildings with dark roofs are concentrated in a small area.

High Occupancy

High Occupancy Space is an area with an occupant density of 40 people or more per 1,000 square feet (25 square feet or less per person). For example a space that is 500 square feet with at least 20 occupants qualifies as high occupancy.

Hot Water Recirculation

The operation of circulators is determined by the circulation system within which they are installed. Three main types of hot water circulation systems exist. In a continuous circulation system, the circulator is in constant operation. In a regulated circulation system, operation of the circulator is governed either by a timer, aquastat or both. In an on-demand system, a manual switch or sensor is used to activate the pump prior to hot water use.

Heating Seasonal Performance Factor (HSPF)

The total heating output of a heat pump during its normal annual usage period for heating (in Btu) divided by the total electric energy input during the same period.

I**Infill**

The use of vacant land and property within a built-up area for further construction or development.

Insulated Ceiling Air Tight (ICAT)

Recessed can light rating that indicates air-tight fixture design intended for insulation contact.

Integrated Energy Efficiency Ratio (IEER)

A measure that expresses cooling part-load EER efficiency for commercial unitary air-conditioning and heat pump equipment on the basis of weighted operation at various load capacities.

Integrated Part-load Value (IPLV)

A single-number figure of merit based on part-load EER, COP, or kW/ton expressing part-load efficiency for air-conditioning and heat pump equipment on the basis of weighted operation at various load capacities for the equipment.

Intermittently Occupied Spaces

Spaces that are accessed at irregular intervals throughout the day, such as restrooms, conference rooms, meeting rooms corridors/hallways, storage rooms/closets, mechanical rooms, break rooms.

L**Low Impact Development (LID)**

A land planning and engineering design approach to managing stormwater runoff. LID emphasizes conservation and use of on-site natural features to protect water quality.

Lighting Power Density (LPD)

Lighting power density is the maximum allowable lighting density permitted by the code. It is expressed in watts per square foot for a given occupancy/space type.

M**Minimum Efficiency Reporting Value (MERV)**

A measurement scale designed in 1987 by ASHRAE to rate the effectiveness of air filters.

O**Occupancy Sensor**

A device that detects the presence or absence of people within an area and causes lighting to be regulated accordingly.

P

Pascal

A Pascal (Pa) is a small metric unit of pressure and is commonly used in lieu of inches of water column (1" water column = 248 Pa).

Perennial Plant A plant that lives for more than two years.

Post-Construction Leakage to Outside (PCO)

The PCO is the amount (CFM) of air lost from the duct system into unconditioned spaces, expressed as a percentage of the total square footage of the zone served by that system. The duct leakage shall be determined when pressurized to +25 Pascals (0.1" of water column).

Potable Water

Water pure enough to be consumed or used with low risk of immediate or long term harm.

Previously Developed Land

Land which is or was occupied by a permanent structure.

Property Boundary

This may be considered the actual property boundary or the area which is bound by limits of construction activity. Property Boundary area is determined at the Design and Planning Review and must remain consistent across the program worksheet.

R**R-Value**

A measure of the capacity of a material, such as insulation, to impede heat flow; the inverse of the Ufactor. The larger the R-value, the less heat is transmitted.

S**Seasonal Energy Efficiency Ratio (SEER)**

The total cooling output of an air conditioner during its normal annual usage period for cooling (in Btu) divided by the total electric energy input during the same period (in Wh).

SFBE (Square Footage of Building Envelope)

The total square footage of building's thermal envelope: Building Envelope Floor plus Exterior Insulated Wall plus Insulated Ceiling/Roofline.

Solar Heat Gain Coefficient (SHGC)

The SHGC is the fraction of incident solar radiation admitted through a window, both directly transmitted and absorbed and subsequently released inward. SHGC is expressed as a number between 0 and 1. The lower a window's solar heat gain coefficient, the less solar heat it transmits.

Solar Reflectance Index (SRI)

A temperature scale calculated from solar reflectance and thermal emittance values used as a metric for comparing the coolness of roof surface types.

Square Footage of Building Envelope (SFBE)

The sum of the building envelope that separates conditioned from unconditioned space.

T

Thermostatic Expansion Valve (TXV)

The thermostatic expansion valve regulates refrigerant flow by maintaining a nearly constant superheat at the evaporator outlet. The effect of this type of regulation is that it allows the evaporator to remain as nearly fully active as possible under all load conditions.

U**U-Factor**

The measure of how well an assembly (a window, door, or other construction element) conducts heat; the inverse of the R-value. The smaller the U-factor, the less heat is transmitted.

V**Vacancy Sensor**

An occupancy sensor which acts to turn lights off automatically soon after an area is vacated, but which requires occupants to turn lights on manually when they re-enter the area.

W**WaterSense**

WaterSense is program of the Environmental Protection Agency (EPA) that promotes water efficiency. WaterSense recognizes water efficient products such as toilets, faucets, and showerheads that have met rigorous, third-party verified performance standards.

Wet Area

Any room or area with toilets, urinals, sinks or showers.

X**Xeriscape**

Landscaping and gardening in ways that reduce or eliminate the need for supplemental water from irrigation.

Z**Zone CFA**

Zone Conditioned Floor Area is the total floor area served by each individual HVAC duct system.

