



EarthCraft Multifamily Renovation Technical Guidelines

Updated 2024

Introduction

The EarthCraft™ green building program, first developed in 1999 as a single-family building certification system through a partnership between the Greater Atlanta Home Builders Association and Southface Energy Institute, is designed to specifically address the challenging energy, water and climate conditions of the Southeast.

EarthCraft certification helps ensure that buildings and communities meet strict criteria for reducing energy and water consumption, maintain healthy indoor air quality, and protect our land and natural resources. To achieve an EarthCraft certification a building must be constructed by a certified EarthCraft Builder and undergo independent third-party verification by a qualified EarthCraft Technical Advisor, both of whom confirm that the building meets all program requirements.

Today, the family of EarthCraft green building programs includes:

- The EarthCraft House™ program is designed to certify new construction single- family detached homes, townhomes and duplexes. Any size or type of home can be certified because builders are able to select which program measures are best suited for the project while meeting minimum thresholds for performance.
- EarthCraft House Renovation offers remodelers the unique opportunity to certify renovated, remodeled, and expansion projects of various sizes and complexity. Projects are assessed, and recommendations are made utilizing specific renovation techniques that are designed to optimize energy and water efficiency improvements, indoor air quality and comfort based on the existing characteristics of the building.
- EarthCraft Multifamily is designed to certify new or renovated multifamily developments. The entire project is assessed on environmental performance, livability and affordability.
- EarthCraft Light Commercial certifies new or renovated small-scale commercial buildings of 50,000 ft² or less.
- EarthCraft Sustainable Preservation provides a certification pathway for building performance for buildings that are historic and/or historically significant.

The EarthCraft Multifamily Renovation (ECMF-R) Technical Guidelines apply to all renovated multifamily developments that include one or more low-rise, mid-rise or high-rise structure. The Technical Guidelines must be used in conjunction with the ECMF-R Worksheet and are intended to provide explanations and verification criteria for each line item on the Worksheet.

Projects seeking clarity beyond what is provided in the Technical Guidelines should consult an EarthCraft Technical Advisor.

In addition to meeting ECMF-R program requirements, all local building codes must be met. When local building codes are more stringent than the Technical Guidelines and Worksheet, the local code must be followed. Should the EarthCraft Technical Guidelines and Worksheet conflict with local code, the local code must be followed. The builder must work with their EarthCraft Technical Advisor to determine any changes required for the project to meet local codes.

Additions and updates are made by EarthCraft to the Technical Guidelines as needed and requested.

Technical Guidelines versions may be determined by the version date in the lower left corner of the document. The latest Technical Guidelines are available for free download from the EarthCraft website at www.earthcraft.org. To make recommendations for improvements and updates to the Technical Guidelines, please contact EarthCraft or an EarthCraft Technical Advisor.

All EarthCraft worksheets include requirements that must be met by all certified projects and optional credits that projects may pursue in order to achieve higher levels of certification. Each program worksheet includes a brief description of these requirements and credits, and the corresponding Technical Guideline document provides further explanation, as well as clarifications and ways that the Technical Advisor may verify that the requirement has been met and/or the credit achieved.

Materials and methods described within these Technical Guidelines are representative of typical strategies for meeting criteria, but do not represent all strategies that may be used by a project. Builders may request permission from EarthCraft, through the EarthCraft Technical Advisor, to use a different approach for meeting the criteria; approval must be requested and approved prior to implementation.

Line items with multiple options will be designated through the use of numbers or letters, with specific criteria associated with each number or letter. Numbered items indicate criteria that may be added together on the EarthCraft Multifamily 2020 Worksheet for cumulative points; lettered items indicate criteria that may not be added together (the project may only receive credit for one of the options listed).

- For example, credit option SP 1.0: Create new or enhance existing pedestrian access, all five measures may be met or only one measure may be met since a site may have pedestrian access to a bus line, rail transit, bike path, public greenspace, and/or mixed uses. In comparison, SP 1.1: Reduce heat island effect, only one item, either A or B, may be counted towards EarthCraft certification.

In some cases, requirements or credits may have clarifications that provide more details on how a specific item may be met through common trade-offs and/or alternative verification methods, as trade-offs are allowed within the program.

Most requirements and credits include one or more examples of criteria fulfillment and are often used to demonstrate calculations, as applicable.

Additional resources are also provided as a quick reference for resources that may be used for additional information pertaining to criteria. Any additional resources provided in these Technical Guidelines are not intended to be an exhaustive list of references and products that may be used to meet criteria.

When verifying line items for an EarthCraft project, EarthCraft Builders and EarthCraft Technical Advisors should reference the guidelines to ensure all requirements have been met. The Confirmation language articulates when the official confirmation activity should take place and how, and whether any documentation is required. All criteria must be confirmed before points are awarded on the EarthCraft Multifamily Worksheet.

Confirmation occurs primarily at either the pre-drywall inspection, the final inspection, or at both the pre-drywall inspection and final inspection. Each confirmation type (see below) confirms compliance with

criteria as specified in the criteria and clarifications sections of each line item. The type(s) of confirmation is based on a set of standard options as follows:

- **Visual:** Indicates confirmation of fulfillment of criteria via direct visual inspection by the EarthCraft Technical Advisor.
 - The type of visual confirmation required is dependent on the criteria and should at a minimum include a direct visual inspection by the EarthCraft Technical Advisor.
 - For example, if the project is pursuing credit for recycling waste, in addition to reviewing the documented waste management plan provided by the builder, the EarthCraft Technical Advisor will visually confirm that materials are being recycled on site by seeing recycling signage and separation piles and confirming no materials meant for recycling are in the trash (e.g., no contractor beverage containers are in the dumpster).
 - If unable to confirm compliance with criteria through this option, the EarthCraft Technical Advisor may require documentation or photo confirmation.
- **Verbal:** Indicates confirmation of fulfillment of criteria via direct conversation between the builder and EarthCraft Technical Advisor.
 - The type of verbal confirmation required is dependent on the criteria and should at a minimum include a reasonable explanation by the builder of how the criteria were met. Verbal must be documented in writing and agreed upon by both the Technical Advisor and EarthCraft Builder.
 - If unable to confirm compliance with criteria through this option, the EarthCraft Technical Advisor may require documentation or photo confirmation.
 - If the EarthCraft Technical Advisor identifies any discrepancy between the verbal description provided and visual inspections performed on the project, the visual evidence rules.
- **Documentation:** Indicates confirmation of fulfillment of criteria via documentation provided by the builder and reviewed by the EarthCraft Technical Advisor.
 - The type of documentation required is dependent on the criteria. For example, criteria dependent on calculations should be demonstrated through the documentation of those calculations. Other common forms of documentation include site plans, building plans, product specifications, product warranties, test results, etc. The documentation must provide sufficient information for the EarthCraft Technical Advisor to confirm the criteria were met and should not require the EarthCraft Technical Advisor to conduct further research or calculations.
 - Documentation, as specified in the confirmation area for each line item, may either be:
 - Presented at or before the applicable inspection and kept on file by the builder for a minimum of three years;
 - Submitted to the EarthCraft Technical Advisor at or before the applicable inspection and kept on file by the EarthCraft Technical Advisor for a minimum of three (3) years.
 - Documentation applicable to multiple projects may be presented and/or submitted once and kept on file by the appropriate party. Updates to documentation are required whenever there is a change in methods or materials. EarthCraft Technical Advisors are required to visually reconfirm documentation accuracy at each inspection.

- Photo documentation provided by the builder and reviewed by the EarthCraft Technical Advisor is acceptable for verifying requirements and/or credits if they are installed at a time when the Technical Advisor may not be physically present onsite.
- **Testing:** Indicates confirmation of fulfillment of criteria via diagnostic testing performed primarily by the EarthCraft Technical Advisor.
 - Tests not performed by the EarthCraft Technical Advisor must be performed by a third-party approved by the EarthCraft Technical Advisor and not having a direct conflict of interest. For example, HVAC flow testing must be performed by a third-party not associated with the HVAC contractor. The EarthCraft Technical Advisor must review test results for reasonableness.
 - Proper industry-accepted testing protocols must be followed in addition to the specific measures outlined in the following guidelines, including properly calibrated and maintained equipment.

Instructions

The EarthCraft Builder must complete an EarthCraft worksheet showing that the project will qualify for certification. Each project for which a builder seeks certification must have a completed worksheet unique to the project.

The EarthCraft Builder must download the most recent worksheet from the EarthCraft website before new projects seek verification of program compliance and before each design review. The builder analyzes the project prior to construction and selects the credits they anticipate earning by placing an appropriate score next to each point value. The EarthCraft Technical Advisor reviews the worksheet at the Design Review, Pre- Drywall Inspection, and Final Inspection to clarify any questions that arise during implementation, collect the required documentation (varies per line item), and verify specific measures (varies per line item).

EarthCraft provides the EarthCraft Multifamily Technical Guidelines for your individual use and to copy as-is, or in part as needed. No content may be altered. In exchange for this authorization, you agree to honor all copyright and other proprietary notices contained in the Technical Guidelines. You also agree not to sell or modify the Technical Guidelines.

Also, please note that none of the parties involved in the funding or creation of the Technical Guidelines, including EarthCraft, Southface, the Greater Atlanta Home Builders Association and all associated members, make any warranty (express or implied) or assume any liability or responsibility in relation to you or any third parties for the accuracy, completeness, or use of, or reliance on, any information contained in the Technical Guidelines, or for any injuries, losses or damages (including, without limitation, equitable relief) arising out of such use or reliance.

As a condition of use, you agree not to sue, and agree to waive and release EarthCraft, Southface, the Greater Atlanta Home Builders Association and all associated members from any and all claims, demands and causes of action for any injuries, losses or damages (including, without limitation, equitable relief) that you may now or hereafter have a right to assert against such parties as a result of your use of, or reliance on, the Technical Guidelines.

Please note that the builder (or primary project manager) is solely responsible for choosing the EarthCraft Multifamily criteria that are appropriate for the project and for their proper fulfillment. EarthCraft and its representatives are responsible only for verifying the completion of EarthCraft requirements as set forth in the Technical Guidelines; such verification in no way constitutes a warranty as to the appropriateness of the selected EarthCraft criteria or the quality of implementation.

Contents

- Introduction 2
- Site Planning 19
 - SP 1: Site Design..... 20
 - SP 1.0: Create new or enhance existing pedestrian access to: 20
 - SP 1.1 Reduce heat island effect 22
 - SP 1.2 Permanent stormwater control..... 23
 - SP 1.3 Street trees are 40’ on center at minimum (1 point) 24
 - SP 1.4 Improved connectivity to adjacent sites..... 25
 - SP 1.5 Community gardens 26
 - SP 1.6 Parking reduced below local ordinance (1:1 ratio) (1 point) 27
 - SP 1.7: Reduction of impervious surfaces..... 27
 - SP 1.8: Reduce light pollution all exterior lights full cutoff (2 points) 28
 - SP 1.9: Outdoor Community Gathering Space..... 29
 - SP 2 Site Preparation and Preservation Measures 30
 - SP 2.0 Workshop on erosion and sediment control (requirement) 30
 - SP 2.1 Site assessment identifying all greenspace and tree-save potential (requirement) 30
 - SP 2.2 If major land disturbance occurring, erosion and sedimentation control plan (requirement)..... 31
 - SP 2.3 Do not install invasive plants on site (requirement) 32
 - SP 2.4 Comply with all federal, state, and local government erosion control and tree protection measures (requirement)..... 33
 - SP 2.5 Phase I environmental testing and remediation plan (requirement)..... 33
 - SP 2.6 On-call personnel designated for erosion control during rain events (requirement) 33
 - SP 2.7 Downstream water quality testing (if applicable) (requirement)..... 34
 - SP 2.8 Road/vehicle cleaning protocols posted and enforced (requirement) 35
 - SP 2.9 Tree preservation and protection measures employed on site (2 points) 36
 - SP 2.10 Enhance total tree count: tree planting: 12 trees per acre, trees ≥3” diameter (2 points)..... 37
 - SP 2.11 Landscape plan includes local, endangered plant species: ≥50% of total plantings (1 point)... 37
 - SP 2.12 Landscape plan includes species that serve as pollinators (1 point) 38
 - SP 3 Alternative Transportation Accommodations 39
 - SP 3.0 Onsite community bike storage 39
 - SP 3.1 Electric vehicle charging stations..... 40
 - SP 3.2 24-hour resident access to business center (1 point) 40
 - SP 3.3 Public transportation amenities 41

Construction Waste Management.....	42
CW 1.0 No construction materials burned or buried on site (requirement).....	42
CW 1.1 Only state-approved landfills may be utilized (requirement).....	42
CW 1.2 Donation of salvageable material for reuse (2 points).....	43
CW 1.3 Post waste management plan and divert $\geq 75\%$ from landfill.....	43
Resource Efficiency	45
RE 1: Local, Recycled, and/or Natural Content Materials.....	46
RE 1.1 Sustainably harvested lumber: use no tropical wood.....	46
RE 1.2 Use building materials extracted, processed, and manufactured ≤ 500 miles of site (1-5 points)	46
RE 1.3 Exterior cladding and trim $\geq 25\%$ recycled content material on $\geq 75\%$ area (2 points).....	47
RE 1.4 Insulation $\geq 25\%$ recycled content material and SCS certified (1 point)	47
RE 1.5 Flooring	48
RE 1.6 Engineered trim.....	49
RE 1.7 Roofing material $\geq 50\%$ recycled content material on $\geq 90\%$ area (2 points).....	49
Durability & Moisture Management (DU).....	50
DU 1: Products and Applications	50
DU 1.0 Install drainage plane per manufacturer’s specifications (requirement).....	50
DU 1.1 Integrate new drainage plane with: (requirement).....	51
DU 1.2 Double layer of either building paper or house wrap behind newly installed cementitious stucco, stone veneer or synthetic stone veneer on framed walls (requirement).....	54
DU 1.3 Roof gutters discharge water $\geq 5'$ from foundation (requirement)	56
DU 1.4 Flashing (requirement).....	57
DU 1.5 Maintain 2" clearance between wall siding and roof surface (requirement).....	60
DU 1.6 Install air conditioner condensing unit pad (requirement)	60
DU 1.7 Roof drip edge with $\geq 1/4"$ overhang (requirement)	61
DU 1.8 Drain pan for water heaters and washing machines (requirement)	62
DU 1.9 Enclosed crawlspace, if applicable to design (2 points)	63
DU 1.10 Moisture-resistant wallboard in kitchen, bathroom(s), and laundry, if applicable to project scope (2 points).....	64
DU 1.11 Vented rain screen behind exterior cladding (3 points).....	65
DU 1.12 Flashing at bottom of exterior walls integrated with foundation drainage system (2 points)..	66
DU 1.13 Alternative termite control with no soil pre-treatment (2 points).....	67
DU 1.14 Non-toxic lumber treatment.....	67

DU 1.15 Exterior cladding ($\geq 75\%$ facade) with 30-year warranty (2 points)	68
DU 1.16 Windows, doors, and skylights with ≥ 25 -year warranty (1 point)	68
DU 1.18 Roofing warranty	68
DU 1.19 Drain pan for clothes washers (1 point)	69
DU 2: Moisture Management	70
DU 2.0 100% coverage of ≥ 12 mil vapor barrier in crawlspace (requirement)	70
DU 2.1 Patio slabs, walks and driveways sloped $\geq 1/4$ inches per 1 foot away from the building foundation for ≥ 10 feet or to the edge of the surface, whichever is less (requirement)	71
DU 2.2 Vapor barrier installed under slabs (if applicable) and in crawlspaces only and not on vertical surfaces (requirement)	71
DU 2.3 Final site grade sloped $\geq 1/2$ inch per 1 foot away from the building foundation for ≥ 10 feet or to the edge of the site, whichever is less (requirement)	72
DU 2.4 Existing building materials removed/cleaned within 2 feet minimum radius of water damage (requirement)	72
DU 2.5 Existing vapor barriers on vertical surfaces removed or remediated based on EarthCraft approval (requirement)	73
DU 2.6 Drainage board and damp proofing for below-grade walls (requirement)	73
DU 2.7 Foundation drain at outside perimeter edge of footing surrounded with 6" clean gravel and fabric filter (2 points)	74
DU 2.8 Dedicated dehumidification system in basement and/or closed crawlspace areas (2 points)	75
DU 2.9 Design for or install additional dehumidification	75
DU 2.10 Humidistat or thermidistat used with whole-house variable speed cooling system (2 points)	76
Indoor Air Quality (IAQ)	77
IAQ 1: Combustion Safety	77
IAQ 1.0 No unvented combustion fireplaces, appliances, or space heaters (requirement)	77
IAQ 1.1 All gas furnaces are sealed-combustion appliances (requirement)	78
IAQ 1.2 Sealed-combustion, direct vent or power vent gas water heater(s) (requirement)	78
IAQ 1.3 All fireplaces have outdoor combustion air supply and gasketed doors (requirement)	79
IAQ 1.4 Carbon monoxide detector in all residential units (requirement)	79
IAQ 1.5: Combustion Appliance Zone testing performed on a sample of existing occupied units with gas appliances (requirement)	80
IAQ 2: Indoor Pollutant Control	81
IAQ 2.0 Protect all ducts in floors and open returns until floor finishing is complete (requirement)	81
IAQ 2.1 Filter is easily accessible for maintenance (requirement)	81

IAQ 2.2 Provide rodent and corrosion proof screens with mesh ≤ 0.5 " for all openings not fully sealed or caulked (requirement)	82
IAQ 2.3 All interior paints have < 50 g/L VOC content (requirement)	82
IAQ 2.4 GREENGUARD Certified materials.....	82
IAQ 2.5 Protect ducts until construction is completed (2 points)	83
IAQ 2.6 Protect all bath fans until construction is completed (1 point)	83
IAQ 2.7 No added urea-formaldehyde.....	84
IAQ 2.8 GREENGUARD Gold Certified materials	85
IAQ 2.9 Seal all particle board surfaces with water-based sealant (1 point)	85
IAQ 2.10 No carpet in all units (3 points)	86
IAQ 2.11 Limit carpet installation.....	86
IAQ 2.12 Install permanent walk-off mats at each building entry (1 point).....	86
IAQ 2.13 Flush residential units before occupancy (1 point).....	87
High Performance Building Envelope	88
BE 1.0 IECC adopted by jurisdiction plus applicable state amendments (requirement).....	88
BE 1.1 Energy efficient building envelope design (requirement)	89
BE 1.2 Advanced Energy Consumption Modeling.....	90
BE 1.3 $\geq 40\%$ Reduction in Energy Consumption (10 points)	92
BE 2: Air Sealing Measures	93
BE 2.0 Seal bottom plates to subfloor or foundation for entire unit envelope (requirement)	93
BE 2.1 Block and seal joist cavities (requirement)	95
BE 2.2 Block stud cavities at change in ceiling height (requirement).....	98
BE 2.3 Install blocking and baffles in insulated and vented vaulted ceilings (requirement)	99
BE 2.4 Seal gaps larger than $\frac{1}{4}$ inch at all residence exterior walls, ceilings, and floors (requirement)	100
BE 2.5 Verify air sealing of penetrations at specific locations (requirement)	103
BE 2.6 Install rigid air barriers (requirement)	108
BE 2.7 Install weather-stripping (requirement)	112
BE 2.8 All new recessed can lights must be air-tight and gasketed; IC-rated in insulated ceilings (requirement)	114
BE 2.9 Gypcrete on all framed floors separating unit envelopes (4 points).....	115
BE 2.10 Seal top plate to drywall at the attic level (2 points)	116
BE 2.11 Seal all interior drywall penetrations (4 points).....	117
BE 2.12 Two-pour application of gypcrete in framed areas blocked by drywall (1 point)	117

BE 2.13 Replace existing non-ICAT rated can lights with ICAT rated ones (2 points).....	118
BE 2.14 No recessed lighting installed in insulated ceilings (1 point).....	119
BE 3: Blower Door Test	120
BE 3.0 Envelope leakage is ≤ 7 ACH ₅₀ or ≤ 0.35 ELR, or reduce infiltration by $>40\%$ (requirement)	120
BE 3.1 Envelope leakage is ≤ 5 ACH ₅₀ or ≤ 0.30 ELR (7 points)	121
BE 3.2 Envelope leakage is ≤ 3 ACH ₅₀ or ≤ 0.25 ELR (10 points)	121
BE 4: Insulation	122
BE 4.0 Grade I insulation quality at all building envelope locations (requirement).....	122
BE 4.1 If using loose-fill attic insulation: insulation certificate posted at access door and insulation rulers installed 1 per 300 ft ² (requirement).....	124
BE 4.2 Fibrous insulation is unfaced/friction fit (requirement)	124
BE 4.3 Exterior Wall Insulation (requirement)	125
BE 4.4 Ceiling Insulation (requirement).....	127
BE 4.5 Unconditioned attics (requirement).....	132
BE 4.6 Attic knee wall (requirement).....	135
BE 4.7 Attic pull-down/scuttle hole located in conditioned space: Climate Zone 1/2/3 $\geq R-38$; Climate Zone 4/5 $\geq R-49$ (requirement)	137
BE 4.8 Floor Insulation (requirement)	138
BE 4.9 Steel-framed buildings require thermal break $\geq R-7.5$ (requirement)	140
BE 4.10 Slab edge insulation: Climate Zone 2/3 $\geq R-5$, Climate Zone 4 $\geq R-10$ (3 points)	141
BE 4.11 Corners $\geq R-6$ (3 points)	144
BE 4.12 Headers $\geq R-5$ (3 points).....	146
BE 4.14 Improved exterior wall insulation R-value	147
BE 4.15 Improved ceiling/roof insulation	148
BE 4.16 Insulate with spray foam insulation	149
BE 4.17 Exterior wall cavity insulation $\geq R-15$ (2 points).....	150
BE 4.18 Continuous exterior insulation.....	151
BE 4.19 Insulate basement walls	152
BE 4.20 Attic knee wall insulated $\geq R-22$ with continuous insulated air barrier on attic side (2 points)	153
BE 5: Windows	154
BE 5.0 Exterior Door U-factor (requirement).....	154
BE 5.1 Window U-factor and SHGC (requirement)	154
BE 5.2 Skylight U-factors and SHGC (requirement).....	155

BE 5.3 NFRC-certified doors, windows, and skylights with label (requirement).....	155
BE 5.4 Door U-factor	156
BE 5.5 Window U-factor and SHGC	156
BE 5.6 Skylight U-factor and SHGC	157
BE 5.7 ENERGY STAR Door U-factors and SHGC	157
BE 5.8 Window U-factor and SHGC	158
BE 5.9 Skylight U-factor and SHGC	158
BE 5.10 Minimum 1.5' overhangs over 80% of south-facing window area (1 point).....	159
BE 5.11 Solar shade screens	160
BE 6: Roof.....	161
BE 6.0 HVAC ducts in unconditioned attic	161
Energy Efficient Systems	162
ES 1: Heating and Cooling Equipment	162
ES 1.0 Size and select all HVAC equipment with ACCA Manuals J and S (requirement).....	162
ES 1.1 If programmable thermostat installed for heat pump, include adaptive recovery technology (requirement)	164
ES 1.2 AHRI performance match all indoor/outdoor coils (requirement).....	165
ES 1.3 Non-CFC and non-HCFC refrigerant (requirement)	165
ES 1.4 No electric resistance heat as primary heat source or reheat (requirement)	166
ES 1.5 Heat pump efficiency ≥ 8.8 HSPF/ ≥ 7.5 HSPF2 or equivalent COP (requirement)	166
ES 1.6 Furnace efficiency $\geq 90\%$ AFUE (requirement).....	166
ES 1.7 Cooling equipment ≥ 15 SEER/ ≥ 14.3 SEER2 or 12 EER (requirement)	166
ES 1.8 Filters are \geq MERV 8	166
ES 1.9 Complete ENERGY STAR Multifamily National HVAC Design Report (1 point)	167
ES 1.10 Heating equipment efficiency	168
ES 1.11 Verification of proper refrigerant charge (1 point).....	168
ES 1.12 Cooling equipment ≥ 16 SEER/ ≥ 15.2 SEER2 (2 points)	169
ES 1.13 Condenser units are spaced 2 feet apart (2 points)	169
ES 1.14 Variable speed blower (2 points)	169
ES 1.15 Dual stage compressor (2 points).....	170
ES 1.16 Zone control	170
ES 1.17 Heat pump efficiency >9.0 HSPF/ >7.65 HSPF2 (2 points)	171
ES 1.18 ENERGY STAR cooling equipment ≥ 17 SEER2 (3 points).....	171
ES 1.19 ENERGY STAR Qualified Heating Equipment	172

ES 1.20 Complete ENERGY STAR Multifamily National HVAC Design Supplement – Common Spaces and Central Systems (1 point).....	173
ES 1.21 Cooling equipment and/or cooling mode of heat pump equipment sizing.....	174
ES 2: Ductwork/Air Handler	175
ES 2.0 Seal air handlers and duct systems with mastic products (requirement)	175
ES 2.1 Code-approved solid connector for all flex-to-flex connections (requirement).....	178
ES 2.2 Fully duct all supply, return, and transfer ductwork (requirement)	178
ES 2.3 Duct insulation (requirement).....	179
ES 2.4 No ducts in exterior walls or vaulted ceilings and no plenum within 2' of roofline (requirement)	179
ES 2.5 Locate air handler within conditioned space (requirement).....	180
ES 2.6 Minimize pressure imbalance ≤ 6 pa (requirement)	181
ES 2.7 Indoor coil protected until interior finishes complete (requirement)	182
ES 2.8 No new duct take-offs within 6" of supply plenum/supply trunk cap (requirement)	182
ES 2.9 Two-piece HVAC boot sealed at mechanical connection (requirement)	182
ES 2.10 Minimize pressure imbalance within units ≤ 3 pa (3 points).....	183
ES 2.11 Fully duct all return(s) (5 points).....	183
ES 2.12 Install rigid duct work or pull all flex ducts with no pinches and properly support at intervals $\leq 4'$ (2 points).....	184
ES 2.13 Verify supply and return duct static pressure (2 points)	186
ES 2.14 Measure and balance airflow for each duct run $\pm 20\%$ of design (3 points)	186
ES 2.15 Install ducts per ACCA Manual D duct design (3 points)	187
ES 2.16 Locate all HVAC ductwork within conditioned space (5 points)	187
ES 2.17 HVAC system and ductwork is dry and clean (1 point).....	188
ES 2.18 Duct design and installation	189
ES 2.19 Duct insulation in unconditioned spaces $\geq R-10$ (1 point).....	189
ES 2.20 Return plenum duct take-off free area is 120% of supply plenum duct take-off free area (2 points).....	190
ES 2.21 Ductless HVAC equipment	190
ES 3: Duct Leakage Test Results.....	191
ES 3.0 Test duct leakage based on floor area served (requirement)	191
ES 3.1 Test duct leakage based on floor area served	192
ES 3.2 Test duct leakage based on floor area served: Leakage to Outside $\leq 3\%$ (10 points).....	192
ES 4: Ventilation.....	193
ES 4.0 Design and install a whole-unit ventilation system that is based on ASHRAE 62.2-2010	

ventilation airflow requirements (requirement)	193
ES 4.1 When installed, fresh air intakes must achieve the following standards (requirement)	194
ES 4.2 Seal seams of all intake and exhaust ducts with mastic (requirement)	195
ES 4.3 Install ASHRAE compliant exhaust fans rated at ≥ 50 CFM in all bathrooms and duct to outside (requirement)	195
ES 4.4. Gas kitchen range/or cooktop vented to exterior with ASHRAE compliant ≥ 100 CFM fan (requirement)	196
ES 4.5 Back-draft dampers for kitchen, bathroom, and dryer exhausts (requirement)	196
ES 4.6 ENERGY STAR certified bathroom exhaust fans (requirement)	197
ES 4.7 Duct clothes dryers to outside (requirement)	197
ES 4.8 No power roof vents (requirement)	197
ES 4.9 ENERGY STAR qualified ceiling fans (1 point)	198
ES 4.10 ENERGY STAR bath fans with field verified, measured airflow ≥ 50 cfm (2 points)	198
ES 4.11 Electric kitchen range/or cooktop vented to exterior ≥ 100 CFM fan (3 points)	199
ES 4.12 Verify whole building air ventilation airflow within 20% of design values (2 points)	199
ES 4.13 Install and label accessible ventilation controls, with override controls for continuously operating ventilation fans (1 point)	200
ES 4.14 Bathroom exhaust fans rated ≤ 2 sones (1 point)	200
ES 4.15 Exhaust fan wired with light in bathroom (1 point)	200
ES 4.16 Replace existing bath fan ductwork with round metal duct material that is insulated $\geq R-6$ (2 points)	201
ES 4.17 Radon construction	202
ES 4.18 Bathroom exhaust fan ductwork size	204
ES 4.19 Bathroom exhaust fans rated ≤ 1 sones (2 points)	204
ES 4.20 Automatic bathroom exhaust fan controls with humidistat or timer (2 points)	204
ES 4.21 Energy recovery ventilator for whole-unit ventilation strategy (3 points)	205
ES 4.22 Dehumidifying ventilation system for whole-unit ventilation strategy (5 points)	205
ES 4.23 Vent storage room(s) to outside (1 point)	205
ES 5: Water Heater	206
ES 5.0 No atmospherically vented gas water heaters (requirement)	206
ES 5.1 Heat trap on storage water heater (requirement)	206
ES 5.2 Water Heater Efficiencies (requirement)	207
ES 5.3 High Efficiency Storage Water Heater (2 points)	207
ES 5.4 Tankless gas water heater ≥ 0.95 UEF (3 points)	208

ES 5.5 High Efficiency water heater	208
ES 5.6 Hot water piping insulation \geq R-4 (100%) (2 points).....	209
ES 6: Lighting/Appliances.....	210
ES 6.0 High-efficacy LED lighting in >90% of all permanent fixtures (requirement)	210
ES 6.1 If installed, ENERGY STAR dishwasher (in residential and common areas) (requirement)	210
ES 6.2 If installed, ENERGY STAR refrigerator (in residential and common areas) (requirement).....	211
ES 6.3 If installed, ENERGY STAR clothes washer and dryer kits (in residential and/or communal laundry facility) (requirement)	211
ES 6.4 Residential unit automatic lighting control systems.....	212
ES 6.5 Fixtures and bulbs	212
ES 7: Common Area Lighting/Appliances.....	213
ES 7.0 Common Area Lighting Control Systems (multiple credits available):	213
ES 7.1 Fixtures and bulbs	214
ES 7.2 High-efficiency exterior lighting	214
ES 7.3 High-efficiency Elevators (2 points).....	215
Water Efficiency	216
WE 1: Indoor Water Use	216
WE 1.0 Unit water pressure \leq 60 psi (requirement)	216
WE 1.1 Meet National Energy Policy Act low flow standards for all fixtures (requirement)	217
WE 1.2 Detect no leaks at any water-using fixture, appliance, or equipment (requirement)	217
WE 1.3 EPA WaterSense rated low-flow fixtures (units and common facilities)	218
WE 1.4 Insulate hot water piping to \geq R-3 for all hot water piping located in unconditioned space (requirement)	219
WE 1.5 If installed, water treatment system NSF certified, \geq 85% efficient (2 points)	219
WE 1.6 If installed, water softeners certified to NSF/ANSI Standard 44 (2 points).....	220
WE 1.7 Store \leq 0.5 gal of water between water heater and fixture (2 points)	221
WE 1.8 Ultra-low flow WaterSense labeled fixtures (units and common facilities)	222
WE 1.9 Waterless urinals in common areas, all fixtures (2 points)	223
WE 1.10 Greywater system for toilet flushing (4 points)	223
WE 1.11 Rainwater harvest system for toilet flushing (4 points)	223
WE 1.12 Hot water demand \leq 0.13 gal of water between loop and fixture and \leq 2 gal of water in loop between water heater and furthest fixture (2 points).....	224
WE 1.13 Pipe Insulation	224
WE 1.14 Install leak detection sensors at kitchens, bathroom(s), and laundry in all residential units, or leak monitoring system at main water line to each residential unit (4 points).....	225

WE 2: Outdoor Water Use	225
WE 2.0 Cover all exposed soil with 2"-3" mulch layer (requirement).....	225
WE 2.1 Irrigation system (requirement)	226
WE 2.2 If installed, ornamental water features must recirculate water (requirement).....	226
WE 2.3 Install plants to maintain $\geq 2'$ distance from building(s) at maturity (requirement)	227
WE 2.4 Landscape design.....	227
WE 2.5 Vegetate slopes exceeding 25% (1 point)	228
WE 2.6 Advanced irrigation system design and installation.....	229
WE 2.7 Drought-tolerant/native landscaping turf and plants ($\geq 75\%$) (1 point)	230
WE 2.8 Test and amend soil (1 point)	231
WE 2.9 Alternative irrigation system	231
WE 2.10 Timer on exterior water spigots (1 point)	232
Education and Operations	233
EO 1: Education.....	233
EO 1.0 Provide property manager with project-specific owner's manual (requirement).....	233
EO 1.1 Label all storm drains or storm inlets to discourage dumping of pollutants (requirement)	235
EO 1.2 Local recycling contact (1 point).....	236
EO 1.3 Household hazardous materials resources (1 point)	236
EO 2: Operations and Management	237
EO 2.0 Provide all subcontractors with EarthCraft Multifamily worksheets (requirement)	237
EO 2.1 Market EarthCraft Multifamily program (1 point)	237
EO 2.2 EarthCraft HVAC training (2 points).....	238
EO 2.3 EarthCraft resources provided to leasing office and/or included on property website (2 points)	239
EO 2.4 EarthCraft training provided to property management prior to completion of certification (2 points)	239
EO 2.5 Environmentally friendly cleaning package for ongoing building maintenance (1 point)	240
EO 2.6 Environmental management and building maintenance guidelines for staff (1 point)	240
EO 2.7 Community Recycling Facility (2 point)	241
EO 2.8 Builder quality assurance plan (1 point).....	241
EO 3: Third Party Programs.....	242
EO 3.0 Achieve ENERGY STAR Multifamily Certification (2 Points)	242
EO 3.1 Achieve ENERGY STAR Zero Energy Ready Certification (5 Points).....	242
EO 3.2 Achieve EPA Indoor AirPLUS certification (2 points).....	243

EO 3.3 Achieve WaterSense New Homes Certification (1 point)	243
EO 3.4 Enroll in BIT Building program for property operations and maintenance for minimum one year (2 points).....	243
EO 3.5 EarthCraft Light Commercial Community Center (3 points)	244
Innovation.....	245
IN 1.0 On-site fuel cell or co-generation system (4 points).....	245
IN 1.1 Solar electric system (10% of project demand) (5 points).....	245
IN 1.3 Common areas use solar electric system (80% of demand) (4 points).....	246
IN 1.4 Housing affordability	246
IN 1.5 Developer submits 12 months of pre-renovation energy data (5 points)	247
IN 1.6 Project-specific innovation points	247
Renovations with Additions Supplement	248
RE 1.0 Limit framing at all windows and doors (requirement)	248
RE 1.1 Advanced Framing.....	249
RE 1.2 Average floor area of unit	251
RE 1.3 Floor joists are 24" on center ($\geq 80\%$) (1 point).....	252
RE 1.4 Non-load bearing wall studs are 24" on center (1 point).....	252
RE 2.0 Pre-cast insulated foundation walls ($\geq 90\%$) (2 points).....	252
RE 2.1 Insulated concrete forms or precast autoclaved aerated concrete ($\geq 90\%$)	253
RE 2.2 Engineered wall framing ($\geq 90\%$) (1 point).....	253
RE 2.3 Deliver panelized construction or structurally insulated panels (SIP) to the site pre-framed ($\geq 90\%$).....	254
RE 2.4 All residences are modular construction (5 points).....	255
RE 2.5 Structural headers are steel or engineered wood ($\geq 90\%$) (2 points)	255
RE 3.0 Use recycled concrete or alternate material as aggregate in foundation (1 point)	255
RE 3.1 Replace $\geq 25\%$ of cement in concrete with fly ash or slag	256
DU 1.0 All roof valleys direct water away from walls, dormers, chimneys, etc. (requirement).....	256
DU 1.1 Install termite mesh system (3 points).....	256
DU 1.2 All entrance doors have overhang $\geq 3'$ depth (1 point).....	257
DU 2.0 Gravel bed beneath sub-grade slabs, on grade slabs, or raised slabs (requirement).....	257
DU 2.1 100% coverage of ≥ 6 mil vapor barrier beneath all slabs (requirement).....	257
DU 2.2 Foundation drain on top of sub-grade footing (requirement)	258
DU 2.4 Final site grade sloped $\geq 1/2$ inch per 1 foot away from the building foundation for ≥ 10 feet or to the edge of the site, whichever is less (requirement)	259

DU 2.5 Capillary break between foundation and framing at exterior walls (requirement)	260
DU 2.6 Drainage board and damp proofing for below-grade walls (requirement)	261
DU 2.7 Do not install wet or water-damaged building materials (requirement)	261
DU 2.8 Vapor barriers installed only under slab(s) and/or in crawlspaces (requirement)	262
DU 2.9 Foundation drain at outside perimeter edge of footing surrounded with 6" clean gravel and fabric filter (2 points)	263
DU 2.10 Capillary break.....	264
BE 1.1 Slab edge insulation: Climate Zone 2/3 \geq R-5, Climate Zone 4 \geq R-10 (3 points)	265
BE 1.2 Steel-framed buildings require thermal break \geq R-7.5 (requirement)	267
ES 2.0 Seal air handlers and duct systems with mastic products (requirement)	268
ES 2.1 Code-approved solid connector for all flex-to-flex connections (requirement)	270
ES 3.0 Test duct leakage based on floor area served (requirement)	271
ES 3.1 Test duct leakage based on floor area served	272

Site Planning

The location of an EarthCraft Multifamily project and the plan for the area around that project can have a significant impact on both the residents' quality of life and on the environment. Selecting an appropriate site for a project is essential to creating more walkable, livable communities with efficient transportation. One can also improve the air quality in surrounding areas, help manage storm water, lower energy bills and increase property values simply by protecting and restoring trees on a site. Planning for construction on a site can prevent soil loss and water pollution by reducing erosion and properly controlling for storm water.

The Site Planning category of the EarthCraft program focuses on actions that a project team can take to minimize the direct impact of a development site on the environment. These actions range from protecting excavated topsoil from erosion to reducing lot size. Projects may also implement additional site planning measures to promote accessibility to public amenities such as mass transit and parks; or they may use degraded sites such as brownfields.

SP 1: Site Design

SP 2 Site Design provides credits to projects that locate themselves near alternative transportation, green spaces, and mixed-use areas. Credits are also available in this section for projects that use land use practices and development activities that are considered environmentally preferred.

SP 1.0: Create new or enhance existing pedestrian access to:

SP 2.0 has five options that are available for certification credits, and they may achieve points with one or all of these credits:

1.0.1: Walking distance ($\leq 1/2$ mile) to bus line (2 or 1 points)

- **Criteria:**
 - (A) Existing: Locate a point on the lot boundary that is within 1/2 mile of an existing bus line. Measure distance by following a walkable route comprised of sidewalks, public trails and pedestrian crosswalks. (2 points)
 - (B) Planned: If there is no current bus access within 1/2 mile of the lot boundary, provide an adopted plan by a local or regional authority for bus line expansion and illustrate walkable routes comprised of sidewalks, public trails, and pedestrian crosswalks leading to the bus line should expansion occur. (1 point)

1.0.2: Walking distance ($\leq 1/2$ mile) to rail/rapid transit (3 or 1 points)

- **Criteria:**
 - (A) Existing: Locate a point on the lot boundary that is within 1/2 mile of an existing light rail/heavy rail rapid transit station. Measure distance by following a walkable route comprised of sidewalks, public trails and pedestrian crosswalks. (3 points)
 - (B) Planned: If there is no current light rail/heavy rail rapid transit access within 1/2 mile of the lot boundary, provide an adopted plan by a local or regional authority for rail expansion and illustrate walkable routes comprised of sidewalks, public trails, and pedestrian crosswalks leading to the rail should expansion occur. (1 point)

1.0.3: Biking distance ($\leq 1/2$ mile) to bike path (2 or 1 points)

- **Criteria:**
 - (A) Existing: Locate a point on the lot boundary that is within 1/2 mile of an existing or new bike path. Measure distance by following a bikeable route. (2 points)
 - (B) Planned: If there is no current bike path access within 1/2 mile of the lot boundary, provide an adopted plan by a local or regional authority for bike path expansion and illustrate walkable routes comprised of sidewalks, public trails, and pedestrian crosswalks leading to the bike path should expansion occur. (1 point)

1.0.4: Walking distance ($\leq 1/2$ mile) to public open space or greenspace $\geq 3/4$ acre in size (2 or 1 points)

- **Criteria:**
 - (A) Existing: Locate a point on the lot boundary that is within 1/2 mile of a park that is available for resident use and greater than 3/4 acre in size. Measure distance by following a walkable route comprised of sidewalks, public trails and pedestrian crosswalks. Two smaller parks equivalent in size to one large, 3/4 acre park, are accepted as meeting the intent. (2 points)
 - (B) Planned: If there is no current access to public open space or greenspace within 1/2 mile of the lot boundary, provide an adopted plan by a local or regional authority for increasing connectivity to these spaces and illustrate walkable routes comprised of sidewalks, public trails, and pedestrian crosswalks leading to open space or greenspace should expansion occur. (1 point)

1.0.5: Walking distance ($\leq 1/2$ mile) to business district with mixed uses (2 or 1 points)

- **Criteria:**
 - Locate a point on the lot boundary that is within 1/2 mile of an existing business district that provides a variety of businesses and services available to the public. Measure distance by following walkable route comprised of sidewalks and pedestrian crosswalks.
 - (A) Business district or development with at least 10 or more community resources is eligible for 2 points
 - (B) Business district or development with at least 6 or more community resources is eligible for 1 point

Clarification

Projects may choose to pursue points in one or all of the options, but they may only achieve points for one of the point options within each. For example, a project may achieve points for being within $1/2$ mile of an existing bus line or for being within $1/2$ mile of a planned future bus line, but not both.

Verification

- Project participants must present documentation demonstrating compliance with criteria to the EarthCraft Technical Advisor at EarthCraft Kickoff meeting.
- The EarthCraft Technical Advisor will review documentation provided by the project participants for compliance with criteria.

SP 1.1 Reduce heat island effect

There are three options that are available for certification credits. Projects may only achieve points for one of these options.

SP 1.1.A. Shade 40% of hardscapes on site (2 points)

- **Criteria:** Shade at least 40% of hardscapes, including but not limited to paved areas such as walkways, driveways, patios and tennis courts. Shaded area should be calculated based on tree canopy coverage (after 5 years of tree growth) when the sun is directly overhead.
 - Public walkways and roads should not be included in the hardscape calculation.

SP 2.1.B. Shade/SRI compliance for 60% of hardscapes on site (3 points)

- **Criteria:** Use a combination of shading/SRI compliance for 60% of hardscapes on site. Material SRI must be 30 or greater.

Clarifications:

- This section applies to paved areas only. Credit points for roof surfaces are found in section “BE 6: Roof.”
- Calculation must be based on 12:00 PM on the summer solstice
- To improve durability, install plants and trees to maintain $\geq 2'$ clearance from the foundation at maturity.

Additional Resources:

- Lawrence Berkeley National Laboratory Heat Island Group:
<https://heatisland.lbl.gov/coolscience/cool-pavements>

Verification:

- Project team will submit design and calculations indicating compliance with criteria above. Shade calculations will be required. Product literature will be required for SRI Index.
- The EarthCraft Technical Advisor will visually confirm compliance with criteria at final inspection.

SP 1.2 Permanent stormwater control

There are three options available for certification credits. Projects may achieve points for one of these options.

SP 1.2.A. ≥25% of onsite impervious surface areas (2 points)

SP 1.2.B. ≥50% of onsite impervious surface areas (3 points)

SP 1.2.C. ≥75% of onsite impervious surface areas (4 points)

Criteria:

- Control stormwater runoff away from storm drains on the disturbed site area by integrating Low Impact Development Best Management Practices (LID BMP) into the project. All LID BMP measures should allow water to drain away from the building foundation to protect the building from moisture damage. Acceptable LID BMP include:
 1. Direct impervious surface runoff to appropriately sized rain gardens, swales, drywells or bioretention areas. Receiving area soils should be amended to increase infiltration to the level required for maintaining storm water. Keep area protected from heavy machinery and parking during construction or mitigate soil compaction after construction.
 2. Design and install rooftop gardens and green roofs.
 3. Direct roof or site runoff into rain barrels and cisterns for reuse in the building or for landscape irrigation. Size barrels and cisterns appropriately.
 4. Other EPA and state approved LID BMP: <https://www.epa.gov/water-research/best-management-practices-bmps-siting-tool>
- Use the state-approved LID BMP manual for designing rain gardens, swales or bioretention areas (if applicable to the project).
- Provide the permanent stormwater management plan to scale clearly indicating:
 - Area of disturbed site
 - Permeable and impermeable surfaces
 - Type and location of LID BMPs used
- The LID BMP plan can be integrated into the site plan, landscape plan or erosion control plan.
- The bioretention areas should be sized per the rain event referenced within state water quality control parameters.

Clarifications:

- Landscape installation plan must be consistent with the LID BMPs selected for the project.
- Prior to use, alternatives to LID BMP measures must be approved by EarthCraft.

Additional Resources:

- <http://www.lid-stormwater.net>
- <http://www.nrdc.org/water/pollution/storm/chap12.asp>

Verification

- The project team must present documentation demonstrating compliance with criteria to the EarthCraft Technical Advisor at the pre-drywall inspection.
- The EarthCraft Technical Advisor will review documentation provided by the project team for compliance with criteria and visually confirm compliance with criteria at final inspections.

SP 1.3 Street trees are 40' on center at minimum (1 point)

Criteria: Plant or preserve shade trees at an average interval of 40 feet along $\geq 75\%$ of new or existing streets internal to and immediately adjacent to the project boundary. Trees should be planted on both sides of internal streets and on the project side of adjacent streets.

Verification:

- The project team must present documentation demonstrating compliance with criteria above from the projects landscape designer clearly indicating tree wells or strip dimensions, tree specifications, and street lengths.
- The EarthCraft Technical Advisor will review documentation provided by the project team for compliance with criteria and visually confirm compliance with criteria at final inspections.

SP 1.4 Improved connectivity to adjacent sites

There are two options available for certification credits. Projects may achieve points for one or both options.

SP 1.4.1. Improved vehicular access (2+ connections) (1 pint)

- **Criteria:** The project must provide ≥ 2 connections to the off-site road network. The vehicular access points must include sidewalk accommodations.

SP 1.4.2. Dedicated pedestrian and bike access (1 point)

- **Criteria:** Provide a non-vehicular pathway along the edge of the project's boundary adjacent to developed parcels and undeveloped parcels.
 - Pedestrian and bicycle access to future phases of the same development do not qualify.
 - However, plans to provide access in future phases to adjacent existing sites will qualify.

Clarifications:

- Connections are not required where existing buildings, bodies of water, critical slope areas or other natural areas designated for preservation prohibit through streets.
- Promote multiple road connections off-site to improve vehicular ingress and egress and improve pedestrian connections to adjacent sites.
- No street or pedestrian networks can be gated.

Verification:

- The project team must present documentation showing the locations of connections in compliance with criteria during the EarthCraft Kickoff meeting
- The EarthCraft Technical Advisor will review documentation provided by the project team for compliance with criteria and visually confirm compliance with criteria at final inspections.

SP 1.5 Community gardens

There are two options available for certification credits. Projects may achieve points for only one option.

SP 1.5.A. Enhance existing gardens (1 point)

SP 1.5.B. Create new community garden with planting area larger than or equal to the mean size of all residential units. (2 points)

Criteria: Promote open space and the production of locally grown, community maintained vegetation through community gardening areas. Community gardens provide a catalyst for community development while offering multiple benefits to the environment. Community garden must include:

- A dedicated, fenced garden area with a minimum planting area equal to the mean size of all residential units.
- The gardens must be a permanent fixture within the development, with storage areas provided for garden tools and products.
- Permanent signage dictating rules and safety guidelines at garden entrance.
- Provide a water source nearby for watering the garden. The water source should take into consideration best practices for water conservation. Rain barrels may be used, but not as the primary source of water.
- The soil must be properly prepared for planting.
- Gardens shall be surrounded on all sides with a minimum 4' high fence of weatherproof construction to discourage small children and animals from entering the garden. If pressurized wood is used for fencing or raised-beds, ensure the manufacturer verifies that it is safe to grow edible plants in soil surrounded by their wood product.
- The effects of any contaminants discovered in the Phase I Environmental Assessment must be considered before choosing to build the garden.

Clarification:

If the development has 3 unit types (1 bed is 750 square feet, 2 bed is 900 square feet, and 3 bed is 1200 square feet), determine the mean of the floor plans to determine the required square footage of the garden plot.

$$\frac{750 + 900 + 1200}{3 \text{ unique unit types}} = 950 \text{ square foot community garden}$$

Verification:

- The project team must present documentation showing the location and size of the community garden in compliance with the criteria above at the EarthCraft Kickoff meeting. The garden must also incorporate all requirements listed above in the criteria.
- The EarthCraft Technical Advisor will review documentation provided by the project team for compliance with criteria and visually confirm compliance with criteria at final inspections.

SP 1.6 Parking reduced below local ordinance (1:1 ratio) (1 point)

Criteria: Reduce the amount of parking below a 1:1 ratio and below local zoning ordinance requirements and/or provide no new parking on site.

Verification:

- The project team must present documentation showing the local parking ordinance and the number of parking spaces on site during the EarthCraft Kickoff meeting
- The EarthCraft Technical Advisor will review documentation provided by the project team for compliance with criteria and visually confirm compliance with criteria at final inspections

SP 1.7: Reduction of impervious surfaces

There are multiple options available for certification credits. Projects may achieve points for one or both options.

SP 1.7.A. ≥25% of onsite impervious areas (3 points)

SP 1.7.B. ≥50% of onsite impervious areas (4 points)

SP 1.7.C. ≥75% of onsite impervious areas (5 points)

Criteria: Reduce stormwater runoff from paved surfaces by using pervious or permeable pavement/pavers on outdoor hardscapes and surface parking. Pervious hardscape design and materials must be compatible with site soil and drainage needs. Pavement should drain completely within 48 hours. Points are awarded based on the replacement of existing impervious surfaces with materials that are pervious.

Additional Resources:

- National Association of City Transportation Officials: <https://nacto.org/publication/urban-street-design-guide/street-design-elements/stormwater-management/pervious-pavement/#:~:text=Pervious%20pavement%20effectively%20treats%2C%20detains,lane%20or%20gutter%20strip%20portions>).

Verification:

- The project team must present documentation showing the materials and strategy for pervious surface that is in compliance with the criteria above at the EarthCraft Kickoff meeting.
- The EarthCraft Technical Advisor will review documentation provided by the project team for compliance with criteria and visually confirm compliance with criteria at mid-construction and final inspections.

SP 1.8: Reduce light pollution all exterior lights full cutoff (2 points)

Criteria: Install exterior light fixtures that are designed to minimize glare by shielding their light source to direct it at its intended area. All exterior light fixtures must have full cutoff in order to be eligible for points.

Additional Resources:

- DarkSky: <https://darksky.org/resources/what-is-light-pollution/light-pollution-solutions/>

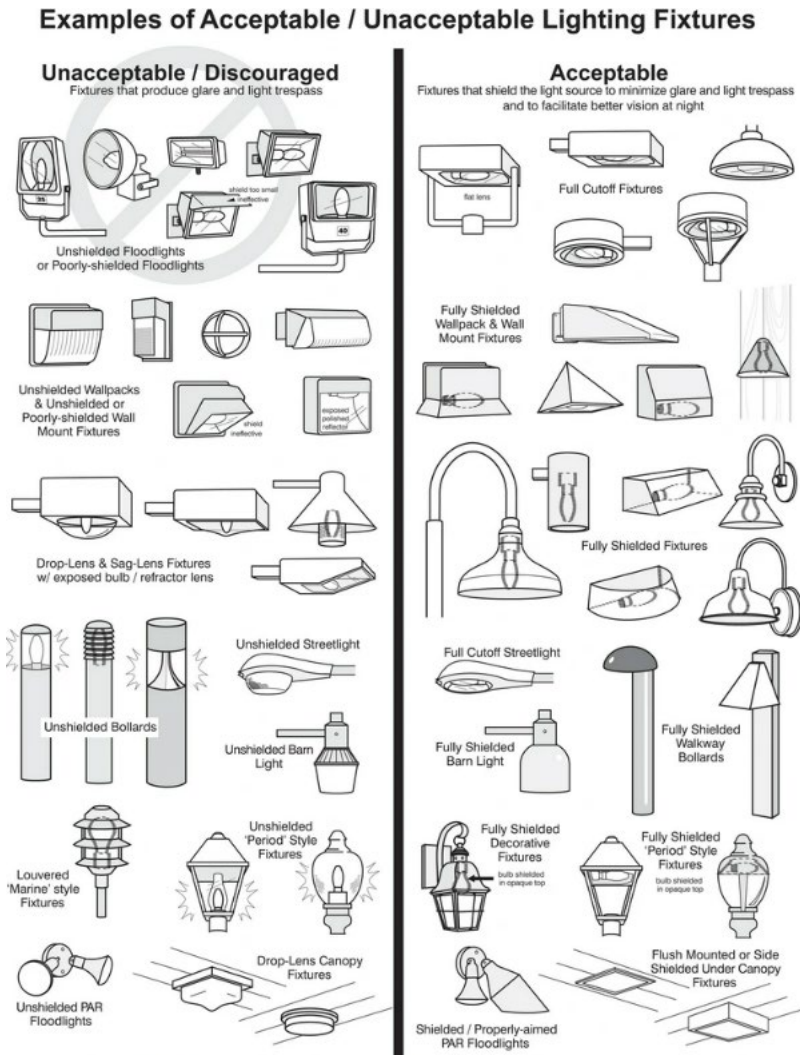

Source: <https://darksky.org/resources/what-is-light-pollution/light-pollution-solutions/>. <https://imgur.com/a/x84vq>

Verification:

- The project team must share architectural/design submittals showing the selection of exterior lighting fixtures for review and approval by EarthCraft Technical Advisor prior to purchase.
- The EarthCraft Technical Advisor will review documentation provided by the project team for compliance with criteria and visually confirm compliance with criteria at mid-construction and final inspections

SP 1.9: Outdoor Community Gathering Space

There are two options available for certification credits. Projects may achieve points for one option.

SP 1.9.A: Enhance existing outdoor gathering space (1 point)

SP 1.9.B: Create new outdoor community gathering space (2 points)

Criteria: Provide a dedicated outdoor community gathering space that includes amenities such as:

- A covered pavilion that provides for seating and/or tables capable of accommodating a minimum of 10% of total residential units.
- Children’s playground with benches or other seating areas

Verification:

- The EarthCraft Technical Advisor will review the planned gathering area during design review phase to determine compliance with criteria.
- The EarthCraft Technical Advisor will visually confirm compliance with criteria during final inspections.

SP 2 Site Preparation and Preservation Measures

SP 3 includes program requirements and certification credit options that focus on responsible land development practices. This section includes several items that are required for all projects as well as items that are worth points.

SP 2.0 Workshop on erosion and sediment control (requirement)

Criteria: Site supervisor must attend and pass examination for either the “Fundamentals of Erosion Control and Sedimentation” workshop or the “Structural and Vegetative Design for Erosion and Sediment Control” workshop, or equivalent offered by the local Soil and Water Conservation Commission. Site supervisor must inform all subcontractors of the Erosion and Sedimentation Control Plan.

Verification:

- The project team must present documentation demonstrating compliance with criteria to the EarthCraft Technical Advisor at the kick-off meeting inspection.
- The EarthCraft Technical Advisor will review documentation provided by the project team for compliance with criteria.

SP 2.1 Site assessment identifying all greenspace and tree-save potential (requirement)

Criteria: Develop a site assessment plan (site plan, aerial photo or sketch) that identifies all greenspace features such as wetlands, stream banks/riparian buffers, steep slopes (15% or greater) and existing trees of 3" caliper or greater. Analyze which areas can be saved via reorientation of building and staging of construction materials and activities.

Verification:

- The project team must present documentation demonstrating compliance with criteria to the EarthCraft Technical Advisor at the pre-drywall inspection.
- The EarthCraft Technical Advisor will review documentation provided by the project team for compliance with criteria.

SP 2.2 If major land disturbance occurring, erosion and sedimentation control plan (requirement)

Criteria: Create an erosion and sedimentation control plan consistent with state or local best management practices. Include all required BMP and tree save practices within the site plan and on site along with LID BMPs meeting SP 2.2 Permanent Stormwater Control, if applicable. All erosion and sedimentation control measures must be maintained throughout the construction process. Include, at a minimum, the following measures:

- Perimeter fencing installed and maintained properly to control runoff and siltation.
- Storm sewer inlets protected with straw bales, compost socks, silt stacks or comparable measures.
- Erosion control blanket used on steep slopes. Steep slopes are defined as areas with a slope $\geq 15\%$ change in elevation.
- If a delay in finished grade is expected, stabilize all disturbed areas with temporary seeding, straw or wood mulch or permanent vegetation immediately after rough grading is completed.
- Protected excavated topsoil areas by perimeter silt fencing or equivalent and use tarps, seeding, mulch, compost or other suitable measures to protect from rain and wind erosion.
- The prepared plan must consist of a project map with the following elements:
 - A location sketch of the project and nearby major roadways, streams and other identifiable landmarks within 200 feet of the project boundary.
 - A location sketch of major, onsite topographic features, streams, existing soil types and vegetation located on the project site. Existing and proposed topographic contours greater than 2 feet should be shown on the sketch.
 - Location and extent of temporary and permanent erosion and sediment control measures including both vegetative and structural practices.
 - Erosion control measures and plan should be maintained by the on-site contractor and adjusted as necessary throughout all construction phases.

Verification:

- The project team must submit documentation demonstrating compliance with criteria to the EarthCraft Technical Advisor at the EarthCraft kick-off meeting.
- Civil engineer or other will provide site plans and documentation showing locations of required BMPs and tree-save protection.
- The EarthCraft Technical Advisor will review documentation provided by the project team for compliance with criteria.

SP 2.3 Do not install invasive plants on site (requirement)

Criteria: EarthCraft will not permit the installation of plant species listed as a Category I or II invasive plant species.

Additional Resources:

Each state assembles their own list of invasive plant species:

- Alabama: <https://www.se-eppc.org/alabama/>
- Florida: <https://www.fleppc.org/>
- Georgia: <https://www.gaepcc.org/list/>
- North Carolina: <http://nc-ipc.weebly.com/>
- South Carolina: <https://www.se-eppc.org/southcarolina/>
- Virginia: <https://www.dcr.virginia.gov/natural-heritage/invspdflist>

Additional state resources may be found here: <https://www.invasivespeciesinfo.gov/us>

Clarifications:

- Bermuda Grass is the only exempted plant species.

Verification:

- Landscape designer will provide a plant list indicating species that are regionally adaptive.
- The EarthCraft Technical Advisor will visually confirm compliance with criteria with the project team at the final inspections.

SP 2.4 Comply with all federal, state, and local government erosion control and tree protection measures (requirement)

Criteria: Project must meet all federal, state and local government erosion control and protection measures.

Verification:

- The EarthCraft Technical Advisor will visually confirm compliance of criteria at pre- drywall and final inspections.

SP 2.5 Phase I environmental testing and remediation plan (requirement)

Criteria: Comply with all federal guidelines regarding Phase I environmental site assessments. If the phase I shows the need for soil or building abatement the team must show compliance with clean-up requirements through the Phase II assessment (or greater).

Verification:

The project team will provide a copy of Phase I assessment results as requested by the EarthCraft Technical Advisor. If additional phase assessments are conducted these may also be requested.

SP 2.6 On-call personnel designated for erosion control during rain events (requirement)

Criteria: The project team must designate on-call personnel for the purpose of maintenance/repair of erosion control measures during rainfall events. The on-call personnel must possess an active level 1A certification from the appropriate state soil and water conservation regulatory body.

Verification:

- The project team will identify the point person and provide a copy of the 1A certification as requested by the EarthCraft Technical Advisor.

SP 2.7 Downstream water quality testing (if applicable) (requirement)

Criteria: The project must comply with stormwater discharge limitations required by the Federal Clean Water Act. If applicable, the general contractor will submit updated Nephelometric Turbidity Units (NTU) reports to the EarthCraft Technical Advisor before, during, and after construction is complete.

Clarification:

- An EC Technical Advisor may request turbidity tests at any time. If test records indicate levels exceeding what is locally allowable, project personnel and contractor are responsible for adjusting best management practices to meet established performance targets.
- If turbidity tests exceed allowable levels for two consecutive storm events, the project will be required to host a mandatory meeting between site contractor, turbidity testing agency and project manager to determine necessary changes for compliance. Documentation of the meeting must be submitted to ECMF.
- If turbidity tests exceed allowable levels for a third consecutive storm event, the project will be unable to certify as an ECMF.
- For allowable limits based on site acreage and stream types please review the NTU limits from your appropriate state authority.

Verification:

- The project team must present documentation demonstrating compliance with criteria to the EarthCraft Technical Advisor during the inspection phase.
- The EarthCraft Technical Advisor will review documentation provided by the project team for compliance with criteria.

SP 2.8 Road/vehicle cleaning protocols posted and enforced (requirement)

Criteria: Designate a tire and vehicle washing area during the construction phase of the project. Create protocols to enforce both vehicle and road cleaning processes.

Clarifications:

- The vehicle cleaning area will have a clean path to, and will be located within 100 feet of, the construction entrance.
- The area should consist of a 32 ft. x 12 ft. gravel bed atop permeable ground and should have adequate water access for washing purposes.
- This area should be properly documented in the Erosion and Sedimentation plan, Site plan, and marked on site. Washing must be enforced.
- The design team should create protocols for off-site road cleaning to remove sediment and debris carried from the construction site.

Verification:

- The project civil engineer or other professional will identify the location and requirements for the above criteria within the projects site plans.
- The EarthCraft Technical Advisor will visually confirm location of the wash out station during the EarthCraft Kick-Off meeting.

SP 2.9 Tree preservation and protection measures employed on site (2 points)

Criteria: Use mature vegetation to create a sense of place, aid in mitigation of heat island effect and preserve natural landscape.

Preserve at least 25% of existing trees that have a chest-height (4 feet above the ground) diameter of 8 inches or more. The tree root zones of the selected trees must be protected with a physical barrier during all site clearing, grading, and construction activities.

Tree Preservation and Protection Plan shall include the following:

- Tree Survey
- Assessment completed by a certified arborist that identifies mature trees onsite and identifies ≥25% that will be protected and their proximity to the building(s) with the project boundary.
 - Assessment should determine which trees are in good health and have cultural, native, aesthetic and/or monetary significance.
- Tree Protection plan that includes:
 - Clearly indicate tree-save areas and protection measures in construction documents.
 - Tree(s) must be fenced around the drip line throughout the construction process with tall, bright, protective fencing.
 - Avoid soil being placed on top of any root zone for trees that are designated for preservation.
 - Ensure the protected tree species' needs for growth, sunlight and water integrate well with the new building design.

Verification:

- The project team will identify tree preservation potential and identify the trees to be saved within the projects site plans.
- The EarthCraft Technical Advisor will visually verify the tree protection measures are appropriately employed and provided for the identified trees.
- Confirmation will begin at the EarthCraft Kick-Off meeting and continue until project completion.

SP 2.10 Enhance total tree count: tree planting: 12 trees per acre, trees ≥3” diameter (2 points)

Criteria: Plant a minimum of 12 trees per acre. All trees must be ≥3” in diameter at breast height (DBH).

Verification:

- Provide site plan with tree planting locations and plant list to EarthCraft Technical Advisor during design review process.
- The EarthCraft Technical Advisor will visually confirm compliance with criteria at final inspection.

SP 2.11 Landscape plan includes local, endangered plant species: ≥50% of total plantings (1 point)

Criteria: Include plants in the landscape plan that are local to the region, with priority given to species that are considered endangered. At least 50% of the total plants on the landscape plan must be considered local and endangered/threatened by the state Cooperative Extension or equivalent authority.

Additional Resources:

Each state assembles their own list of planting guidelines:

- Alabama: <https://www.aces.edu/blog/category/lawn-garden/>
- Florida: <https://sfyl.ifas.ufl.edu/lawn-and-garden/>
- Georgia: <https://extension.uga.edu/topic-areas.html#g>
- North Carolina: <https://gardening.ces.ncsu.edu/>
- South Carolina: <https://www.clemson.edu/extension/horticulture/index.html>
- Virginia: <https://ext.vt.edu/lawn-garden.html>

Verification:

- Provide site plan with plant list and planting locations to EarthCraft Technical Advisor during design review process. Documentation must clearly identify that 50% or more of the plants are considered local and endangered.
- The EarthCraft Technical Advisor will visually confirm compliance with criteria at final inspection.

SP 2.12 Landscape plan includes species that serve as pollinators (1 point)

Criteria: Include plants in the landscape plan that help sustain pollinators such as bees, butterflies, birds, etc. At least 25% of the total plants on the landscape plan must be considered pollinator friendly by the state Cooperative Extension or equivalent authority.

Additional Resources:

Each state assembles their own list of planting guidelines:

- Alabama: <https://www.aces.edu/blog/category/lawn-garden/>
- Florida: <https://sfyl.ifas.ufl.edu/lawn-and-garden/>
- Georgia: <https://extension.uga.edu/topic-areas.html#g>
- North Carolina: <https://gardening.ces.ncsu.edu/>
- South Carolina: <https://www.clemson.edu/extension/horticulture/index.html>
- Virginia: <https://ext.vt.edu/lawn-garden.html>

Verification:

- Provide site plan with plant list and planting locations to EarthCraft Technical Advisor during design review process. Documentation must clearly identify that 25% or more support pollinators.
- The EarthCraft Technical Advisor will visually confirm compliance with criteria at final inspection.

SP 3 Alternative Transportation Accommodations

SP 3 includes certification credits that encourage projects to incorporate features that support alternative transportation that reduce resident reliance on traditional fossil fuel vehicles.

SP 3.0 Onsite community bike storage

There are two options available for certification credits. Projects may achieve points for one or both options.

SP 3.0.1. Outdoor racks based on $\geq 10\%$ of total residential units (1 point)

SP 3.0.2. Covered bike storage facility with racks based on $\geq 10\%$ of total residential units (2 points)

Criteria: Provide bike storage facilities that encourage alternative transportation by residents and their guests to and from the development. Bike storage facilities must be reasonably easy to access for all residents. Residents must be made aware of the presence of bike storage facility locations and be provided with information on how to properly store bike(s).

Clarifications:

- Bike racks may be located in multiple locations throughout the property as long as the total capacity meets the credit criteria.
- Bike storage facilities must include secure infrastructure for locking bikes.
- Proper lighting must be provided to prevent tampering with locked bikes.

Verification:

- The project team will identify bike rack location and capacity on site plan.
- The EarthCraft Technical Advisor will confirm bike storage facilities are complete at final inspection.

SP 3.1 Electric vehicle charging stations

There are two options available for certification credits. Projects may achieve points for only one option.

SP 3.1.A. Total spaces provided are $\geq 1/2$ of the total ADA spaces required for the total development (2 points)

SP 3.1.B. Total spaces provided are greater than or equal to the total ADA spaces required for the total development (4 points)

Criteria: Provide priority parking and charging station for electric vehicles. Points are based on the number of total electric vehicle charging stations provided by the development.

Verification:

- The project team will identify the charging facility locations and capacity on site plan.
- The EarthCraft Technical Advisor will confirm at final inspection.

SP 3.2 24-hour resident access to business center (1 point)

Criteria: Provide community accessible meeting spaces for residents' use. Areas will have internet and phone capacity. Residents will be allowed to sign up and use the meeting space in common areas for private business needs.

Verification:

- The project team will include program in management guidelines and educate residents upon move-in.
- The EarthCraft Technical Advisor will confirm at final inspection.

SP 3.3 Public transportation amenities

Criteria: This development will provide a covered bus stop that meets the intent of the regularly scheduled bus service.

SP 3.3.1 Provide covered seating area at an existing, regularly scheduled bus/mass transit service line (2 points)

SP 3.3.2 At least one new covered bus stop at an existing, regularly schedule bus/mass transit service line (2 points)

Clarifications:

- Projects cannot get this credit for a pre-existing covered bus stop, but they can achieve points for adding a covered seating/standing area at a pre-existing, un-covered bus stop.
- Projects should work with appropriate local office to ensure covered bus stop meets municipal requirements for accessibility

Verification:

- The project team will identify bus stop on site plan.
- The EarthCraft Technical Advisor will confirm at final inspection.

Construction Waste Management

Each year, more than 130 million tons of debris from construction sites is sent to landfills in the United States, which accounts for one quarter of the non-industrial waste in the United States. However, most construction debris from new construction is recyclable, reusable, or may be avoided. By taking simple steps to minimize construction waste, a project team will reduce the amount of waste incinerated or placed in landfills, preventing pollution, and conserving and protecting our natural resources for future generations.

The Construction Waste Management category of EarthCraft Multifamily focuses on ways a project team can reduce the amount of recyclable construction waste sent to landfills and reduce the need to extract virgin raw materials.

CW 1.0 No construction materials burned or buried on site (requirement)

Criteria: No construction materials burned or buried on job site.

Verification:

- The EarthCraft Technical Advisor will verbally and visually confirm compliance with criteria with the project team at the pre-drywall and final inspections. Verification will include site assessment to confirm no burn or burial sites for construction waste, and the location and maintenance of dumpsters.

CW 1.1 Only state-approved landfills may be utilized (requirement)

Criteria: Only state-approved landfills may be utilized for waste disposal.

Verification:

- The EarthCraft Technical Advisor will verbally confirm compliance with criteria with the project team at the pre-drywall and final inspections. Verification will include collection of information on construction waste contractor.

CW 1.2 Donation of salvageable material for reuse (2 points)

Criteria: Avoid disposal of deconstructed and/or excess construction materials by donating materials to a non-profit 501(c) (3) organization or by reusing the construction materials for another job. The value of donated or reused materials must be \$10,000 or greater and a detailed list or receipt must be on file with project team.

Verification:

- The project team must present documentation demonstrating compliance with criteria to the EarthCraft Technical Advisor at the final inspection. This should include the material(s) donated, contact information for the non-profit(s) that received the material(s), and information on how the value of the donation was determined.
- The EarthCraft Technical Advisor will review documentation provided by the project team for compliance with criteria.

CW 1.3 Post waste management plan and divert $\geq 75\%$ from landfill

There are multiple options available for certification credits. Projects may achieve points for one or all options.

Criteria: Post a construction waste management plan on site, educate each subcontractor on the aspects of the plan that pertains to their work, and enforce these measures. Waste management plan must provide for either onsite separation of materials to be recycled or separation of recyclable materials by clean-up or waste hauling firms. Maintain documentation on diversion rate for each material.

CW 1.3.1. Wood (2 points)

- **Criteria:** Avoid disposal of 75% or greater (by weight or volume) of solid sawn wood by recycling through a state or county approved program or by on-site grinding and application of wood chips as mulch. Pressure treated wood is exempt from this requirement and may not be milled or applied as mulch.

CW 1.3.2. Cardboard (1 point)

- **Criteria:** Avoid disposal of a minimum of 75% (by weight or volume) of cardboard generated during construction, including all material packaging.

CW 1.3.3. Metal (including beverage containers) (1 point)

- **Criteria:** Avoid disposal of a minimum of 75% (by weight or volume) of metal generated from construction, including contractor beverage cans.

CW 1.3.4. Drywall (recycle or grind and spread on site) (2 points)

- **Criteria:** Avoid disposal of a minimum of 75% (by weight or volume) of drywall generated from construction through an approved recycling program, or by onsite grinding and application of drywall as a soil amendment.

CW 1.3.5. Plastics (including beverage containers) (1 point)

- **Criteria:** Avoid disposal of a minimum of 75% (by weight or volume) of plastic generated from construction, including contractor beverage containers.

CW 1.3.6. Shingles (2 points)

- **Criteria:** Avoid disposal of a minimum of 75% (by weight or volume) of shingles generated from construction. Recycled shingle scraps offer a variety of uses including gravel substitutes for the wearing surface for rural roads, asphalt cement modifier and aggregate substitute and mineral filler for asphalt paving mixes.

Verification:

- The project team must present documentation demonstrating methods for meeting point requirements to the EarthCraft Technical Advisor at the EarthCraft Kick-Off meeting.
- The EarthCraft Technical Advisor will review documentation provided by the project team for compliance of criteria and will visually confirm compliance with criteria at the ECMF Kick-Off, during pre-drywall inspections and at final inspections.

Resource Efficiency

The EarthCraft Multifamily program encourages projects to minimize the use of . By taking the time to design a project to use less wood and by practicing simple measures to ensure that wood on site is used properly, a new project can reduce its impact the environment as well as cost less money to build.

EarthCraft projects can meet the requirements of the Resource Efficiency category through methods such as designing projects with 2' dimensions, employing advanced framing techniques and providing clear framing plans and cut lists to contractors. These methods not only reduce the amount of lumber used on site, but also save money through reduced material costs and reduced tipping fees. Improvements in energy efficiency brought about by these methods will also increase customer satisfaction.

Building materials come from a variety of sources, not all of which are environmentally friendly. The EarthCraft program strives to reduce the impact projects have on the environment, including the impacts that result from the extraction and manufacture of materials used in construction. By choosing certain building materials, an EarthCraft Builder can conserve natural resources, prevent unnecessary waste and reduce pollution associated with manufacturing and transporting of materials.

RE 1: Local, Recycled, and/or Natural Content Materials

This section of EarthCraft Multifamily encourages projects to reduce waste associated with the construction industry by specifying materials and/or products that are locally sourced and produced; contain recycled content; and/or contain minimally processed natural content.

RE 1.1 Sustainably harvested lumber: use no tropical wood

There are multiple options available for certification credits. Projects may achieve points for one or all options.

RE 1.1.1. Forest Stewardship Council (FSC) certified lumber (≥50%) (2 points)

- Use ≥50% FSC certified lumber for framing, sheathing, and/or other structural wood within the building.

RE 1.1.2. Lumber/millwork: use no tropical wood (2 points)

- Ensure that all wood products sourced for the construction of the development are free of tropical wood species.

Verification:

- The project team must present documentation demonstrating compliance with criteria to the EarthCraft Technical Advisor during mid-construction and final inspections.
- The EarthCraft Technical Advisor will review documentation provided by the project team for compliance with criteria prior to submitting the project for certification.

RE 1.2 Use building materials extracted, processed, and manufactured ≤500 miles of site (1-5 points)

Criteria: Use building materials that 90% by weight or volume have been extracted, processed and manufactured within 500 miles of the site.

- Each product meeting the criteria earns one (1) point; no more than five (5) products may receive credit for these points.

Verification:

- The project team must submit documentation demonstrating compliance with the criteria above. This can come in the form of product literature or official correspondence with a representative of the material manufacturer.

The EarthCraft Technical Advisor will review documentation provided by the project team for compliance with criteria prior to submitting the project for certification.

RE 1.3 Exterior cladding and trim $\geq 25\%$ recycled content material on $\geq 75\%$ area (2 points)

Criteria: Install $\geq 75\%$ of exterior cladding and trim that contains $\geq 25\%$ recycled content material (pre- or post-consumer) by weight or volume.

Verification:

- The project team must present documentation demonstrating compliance with criteria to the EarthCraft Technical Advisor at the mid-construction and/or final inspections.
- The EarthCraft Technical Advisor will review documentation provided by the project team for compliance with criteria prior to submitting project for certification.

RE 1.4 Insulation $\geq 25\%$ recycled content material and SCS certified (1 point)

Criteria: Install 100% of new insulation with $\geq 25\%$ recycled material (pre- or post-consumer) content by weight or volume in all walls, floors and ceilings. Recycled content must be certified by Scientific Certification Systems (SCS).

Additional Resources:

- For more information about SCS-certified insulation visit:
<https://www.scsglobalservices.com/certified-green-products-guide/product/40497>

Verification:

- The project team must present documentation demonstrating compliance with criteria to the EarthCraft Technical Advisor during the mid-construction inspections.
- The EarthCraft Technical Advisor will review documentation provided by the project team for compliance with criteria prior to submitting the project for certification.

RE 1.5 Flooring

There are multiple options available for certification credits. Projects may achieve points for one or all options.

RE 1.5.1. Cork, natural linoleum, sealed concrete or bamboo flooring (≥20% of total floor area) (2 points)

- **Criteria:** Install new cork, natural linoleum, sealed concrete or bamboo flooring on ≥20% of total floor area. Bamboo flooring must be sustainably harvested.

RE 1.5.2. Recycled content tiles (≥30% recycled content material on 100% of tile floor area) (2 points)

- **Criteria:** Install new tile with ≥30% recycled content on 100% of tile floor area. Recycled content must be Scientific Certification Systems (SCS) certified.

RE 1.5.3. Carpet (≥50% recycled content material on ≥50% of all carpeted floor area) (1 point)

- **Criteria:** Install new carpet with ≥50% recycled content (pre- or post-consumer) on 50% of carpet floor area. Recycled content must be Scientific Certification Systems (SCS) certified.

RE 1.5.4. Biodegradable carpet and backing (≥50% of all carpeted floor area) (2 points)

- Install new carpet and backing that is constructed of organic materials (e.g., wool, hemp, etc.) that is readily biodegrade when exposed to moisture and sunlight on 50% of all carpeted floor area.

Clarifications:

- Floor area must equal conditioned floor area used for the confirmed HERS energy model or verified Manual J reports. The floor area must match plans for each unit type and total common area(s).

Additional Resources:

For more information about SCS-certified products visit: <https://www.scsglobalservices.com/certified-green-products-guide>

Verification:

- The project team must present documentation demonstrating compliance with criteria to the EarthCraft Technical Advisor during the design review process and/or after purchasing selected materials.
- The EarthCraft Technical Advisor will review documentation provided by the project team for compliance with criteria prior to submitting project for certification.

RE 1.6 Engineered trim

There are multiple options available for certification credits. Projects may achieve points for one or all options.

RE 1.6.1. Interior (≥80%) (1 point)

- **Criteria:** Install a minimum of 80% of new interior trim from non-solid sawn wood (e.g., finger-jointed wood, medium or high-density fiber board [MDF or HDF], etc.) or non-wood material, such as PVC. All non-solid sawn wood products must have no added urea-formaldehyde.

RE 1.6.2. Exterior, including soffit, fascia and trim (≥75%) (1 point)

- **Criteria:** Install a minimum of 75% of new exterior trim (e.g., soffit, fascia and trim) from non-solid sawn wood (e.g., finger-jointed wood, cementitious fiberboard [MDF or HDF], etc.) or non-wood material, such as PVC. All non-solid sawn wood products must have no added urea-formaldehyde.

Verification:

- The project team must present documentation demonstrating compliance with criteria to the EarthCraft Technical Advisor during the design review process and/or after purchasing selected materials.
- The EarthCraft Technical Advisor will visually confirm compliance with criteria at final inspection.
- The EarthCraft Technical Advisor will review documentation provided by the project team for compliance with criteria prior to submitting project for certification.

RE 1.7 Roofing material ≥50% recycled content material on ≥90% area (2 points)

Criteria: Install roofing shingles, tile, or other equivalent ≥50% recycled content materials on ≥90% of entire roof area.

Verification:

- The project team must present documentation demonstrating compliance with criteria to the EarthCraft Technical Advisor during mid-construction inspections.
- The EarthCraft Technical Advisor will review documentation provided by the project team for compliance with criteria prior to submitting project for certification.

Durability & Moisture Management (DU)

An important aspect of building a sustainable EarthCraft Multifamily project recognizes that proper design and installation are integral to building a durable building with minimal moisture management issues. Reducing the life cycle costs due to maintenance, repair and replacement decreases the impact that construction, and reconstruction, has on the environment. The durability and moisture management section includes items that improve long-term durability, occupant health and comfort.

There are two sections in Durability & Moisture Management: Products and Applications and Moisture Management. Both sections include requirements and credits for building designs, construction practices, and materials that assist in minimizing pest and moisture damage in buildings.

DU 1: Products and Applications

The first section of Durability & Moisture Management, Products and Applications, focuses on materials designed to control bulk moisture intrusion into the building and appropriate applications for drainage planes and water vapor barrier control.

DU 1.0 Install drainage plane per manufacturer's specifications (requirement)

Criteria: A drainage plane must be installed and sealed according to manufacturer's instructions on the entire building assembly exposed to the exterior. All exterior penetrations must be sealed and flashed so as to prevent bulk water from entering the home or damaging the exterior wall assemblies.

Verification:

- The EarthCraft Technical Advisor will determine compliance during mid-construction inspections through:
 - In-person field verification
 - The project team may illustrate compliance with criteria through photo documentation submitted to the EarthCraft Technical Advisor during mid-construction inspections

DU 1.1 Integrate new drainage plane with: (requirement)

Criteria: A drainage plane must be installed and sealed according to manufacturer's instructions on the entire building assembly exposed to the exterior. There are three requirements within this section; all must be achieved by all projects.

DU 1.1.1. Window and door pan flashing at sills and side flashing

- Install water-resistant flashing at the base and sides of all window and exterior door rough openings to direct water leaks out of the wall assembly. Side flashing must extend over sill flashing. All flashing must be integrated with drainage plane.

DU 1.1.2. Window and door head/top flashing

- Install water-resistant flashing at the head of all windows and exterior doors. Flashing must extend a minimum of 6" above the top of the window or door, or per manufacturer's specifications. This head/top flashing must extend over side flashing and be integrated with drainage plane.

DU 1.1.3. Exterior wall cladding

- Install a continuous drainage plane behind all exterior wall cladding and integrate with exterior wall cladding.

Additional Information:

Window and door flashing should be installed along all four sides of the rough opening and be sealed and to the exterior wall drainage plane.

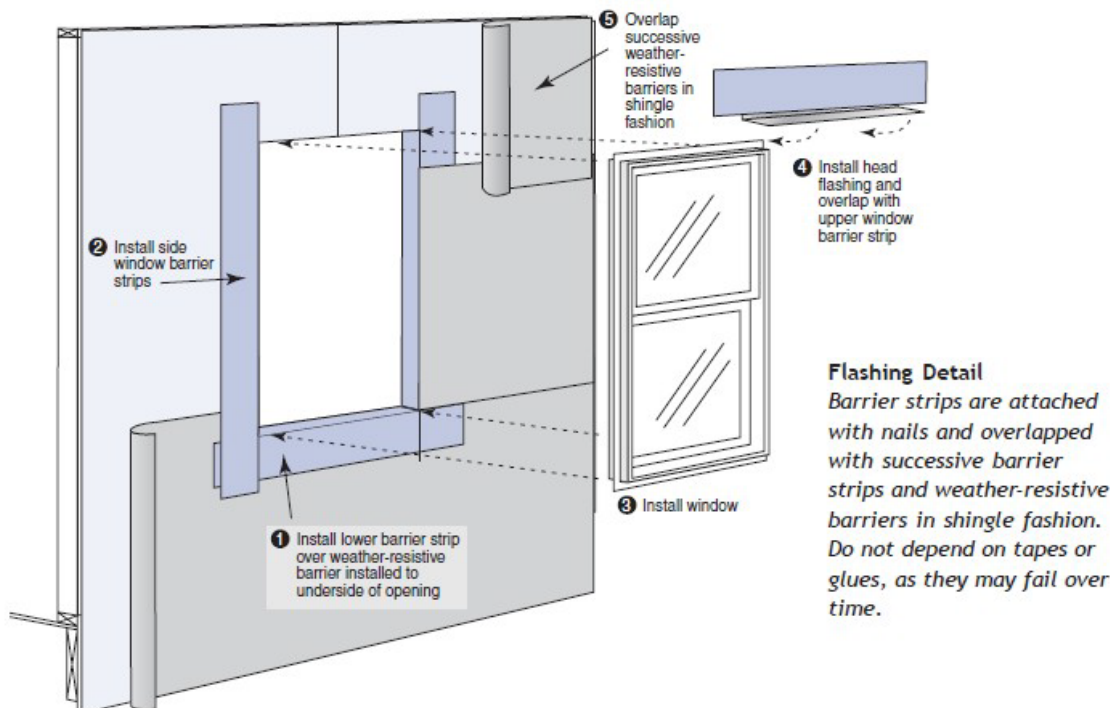

Flashing material should be installed at all exterior openings (windows and doors) to prevent bulk water intrusion behind the exterior wall drainage plane.

Additional resources on window and door flashing may be found at:

- <https://basc.pnnl.gov/resource-guides/windows-and-doors-are-fully-flashed#edit-group-description>

Effective exterior wall drainage planes behind cladding must be continuous bulk water repellent materials that are integrated with flashings and to the bulk water management assemblies of the entire home (ex. roofs, windows, and foundations). Continuous drainage planes may be established using two methods:

- Shingle lapping of materials
- Taping of material joints

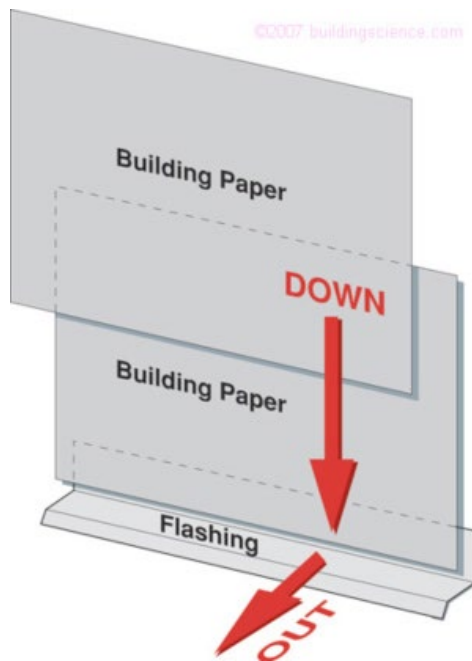

Shingle lapping of water-resistant house wrap integrated with flashing at base of wall assembly

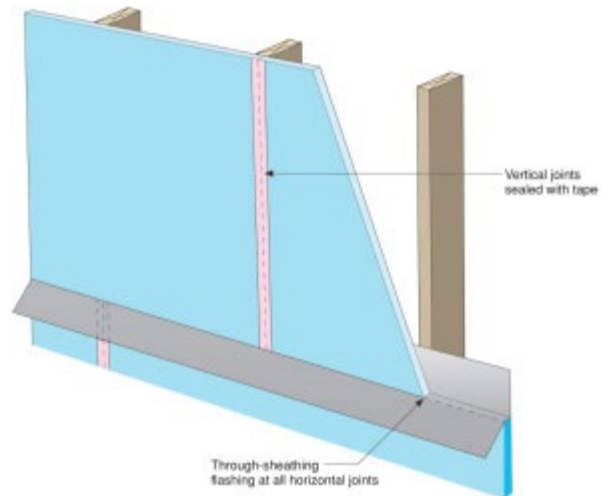

Tapped seams of a sheathing material with integrated water-resistant coating. Tape must be applied to all seams in compliance with manufacturer specifications

Additional information on effective drainage plane installation may be found at:

- <https://basc.pnnl.gov/resource-guides/drainage-plane-behind-exterior-wall-cladding#edit-group-scope>

Clarifications:

- Provide lapping as needed over lintels above window headers for brick cladding, or additional bond-break drainage plane layer provided behind all stucco and non-structural masonry cladding wall assemblies. Include weep holes for masonry veneer and weep screed for stucco cladding systems, according to the manufacturer's specifications.
- Sheathing products with integrated drainage planes, such as OSB with built-in protective overlays and extruded polystyrene foam boards, are not required to have an additional drainage plane installed provided the product is installed per manufacturer's specifications.

Verification:

- The EarthCraft Technical Advisor will determine compliance during mid-construction inspections through:
 - In-person field verification
 - The project team may illustrate compliance with criteria through photo documentation submitted to the EarthCraft Technical Advisor during mid-construction inspections

DU 1.2 Double layer of either building paper or house wrap behind newly installed cementitious stucco, stone veneer or synthetic stone veneer on framed walls (requirement)

Criteria: Install a double layer of either building paper or housewrap behind stucco, stone veneer or synthetic stone veneer on framed walls in order to provide a drainage plane behind materials that absorb and retain moisture.

Additional Information:

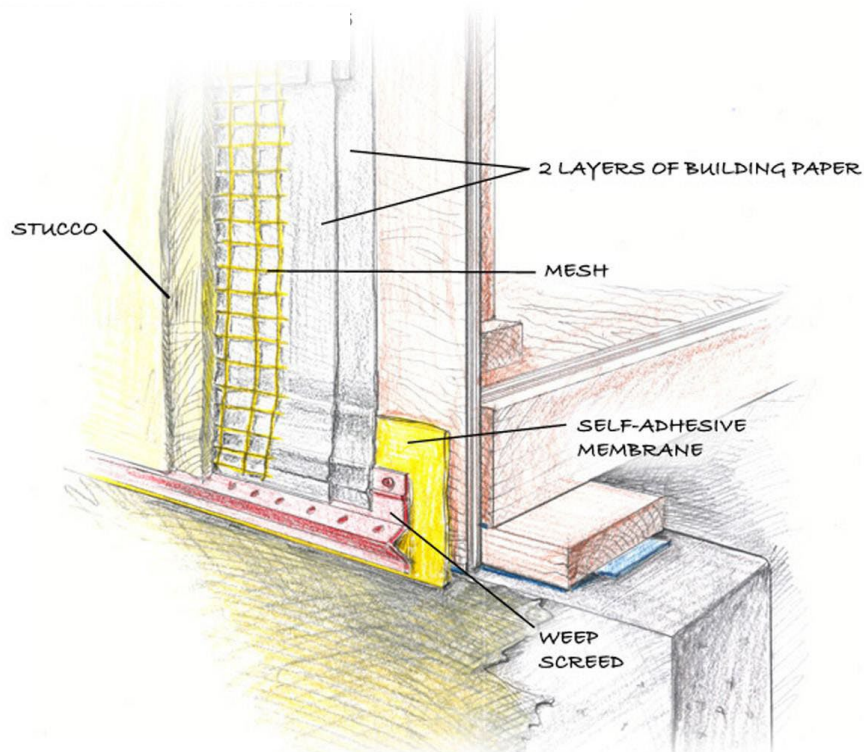

A double layer of house wrap or building paper provides a proper drainage plane behind stucco.

Image source: EPA Indoor airPLUS

Stucco tends to bond to materials it is installed in contact with, such as housewrap and building paper. This results in water seepage through the stucco and housewrap and into wood framing materials behind them. A second layer of housewrap or building paper acts as a bond breaker between the stucco and primary layer of house wrap, protecting the wood framing from moisture damage.

Additional information may be found at:

- “Stucco that Works”, DeKorne, Clayton, Journal of Light Construction, May 1, 2006, https://www.jlconline.com/how-to/exterior/stucco-that-works_o
- Building America Solution Center: <https://basc.pnnl.gov/resource-guides/drainage-plane-behind-exterior-wall-cladding#edit-group-description>

Clarifications:

- All unvented, exterior cladding in contact with the substrate must meet the criteria.
- A single layer of building paper coupled with a single layer of housewrap meets the intent of the criteria.
- For stucco cladding systems, include weep screed per manufacturer's specifications.

Verification:

- The EarthCraft Technical Advisor will determine compliance during mid-construction inspections through:
 - In-person field verification
 - The project team may illustrate compliance with criteria through photo documentation submitted to the EarthCraft Technical Advisor during mid-construction inspections

DU 1.3 Roof gutters discharge water $\geq 5'$ from foundation (requirement)

Criteria: All rain from the roof must be collected in a roof gutter system and directed via downspouts such that water is discharged on a sloping finished grade $\geq 5'$ away from the foundation.

Additional Information:

Gutter and downspout assemblies that comply with this requirement include:

- Permanently gutters and downspouts that terminate at least 5 feet away from all foundations
- Gutters and downspouts that terminate to an underground catchment system at least 10 feet away from foundations.

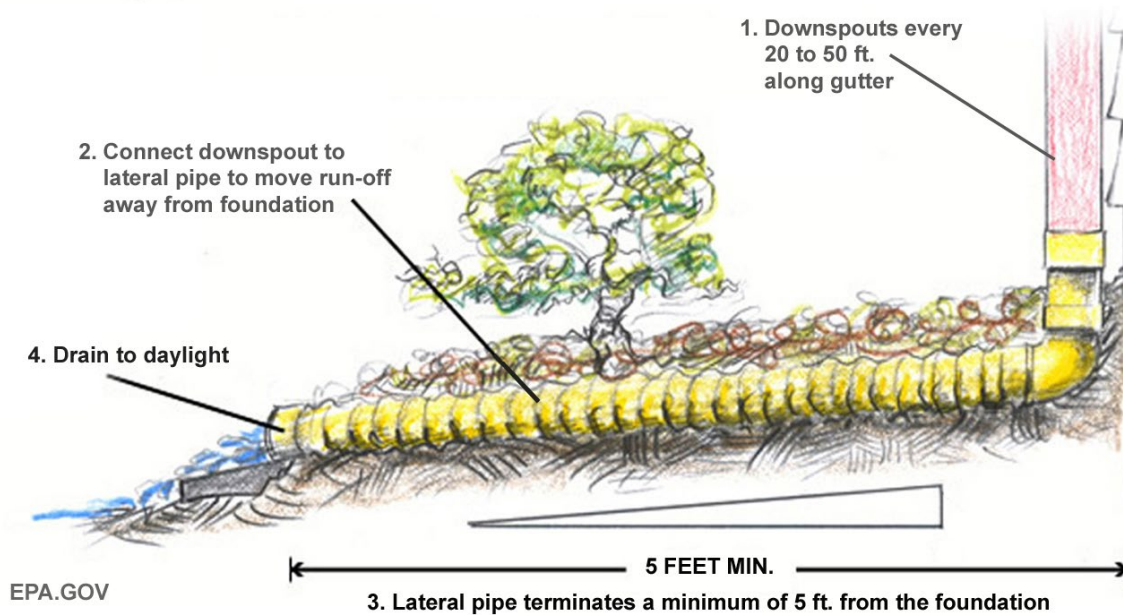

Clarifications:

- When grading is not possible, water must be directed to an underground catchment system (not connected to the foundation drain system) that deposits water a minimum of 10 feet from the foundation.
- Roofs without gutters may be acceptable if rainwater is appropriately deposited to a grade-level rock bed that surrounds the perimeter of the building foundation with waterproof liner and drainpipe that discharges water at least 5 feet from the foundation, or to a drywell or other pre-approved location. If this method is used the building must be protected from splashback damage.
- Rainwater-harvesting systems may be used to meet this requirement if they are able to drain the stormwater overflow to meet requirements above.
- Non-permanent extensions do not qualify.

Verification:

- The EarthCraft Technical Advisor will visually confirm compliance with criteria at final inspection.

DU 1.4 Flashing (requirement)

Criteria: Flashing must be installed at all vertical and horizontal building component intersections at the building exterior, including walls and roofs. There are multiple requirements in this section; all must be met as applicable to building design.

DU 1.4.1. Self-sealing bituminous membrane or equivalent at valleys and roof deck penetrations when existing roof is repaired/replaced

- **Criteria:**
 - Install a self-sealing bituminous membrane or equivalent at all valleys and roof decking penetrations for added durability.
 - Install flashing on all roof penetrations and integrate with roof drainage plan.

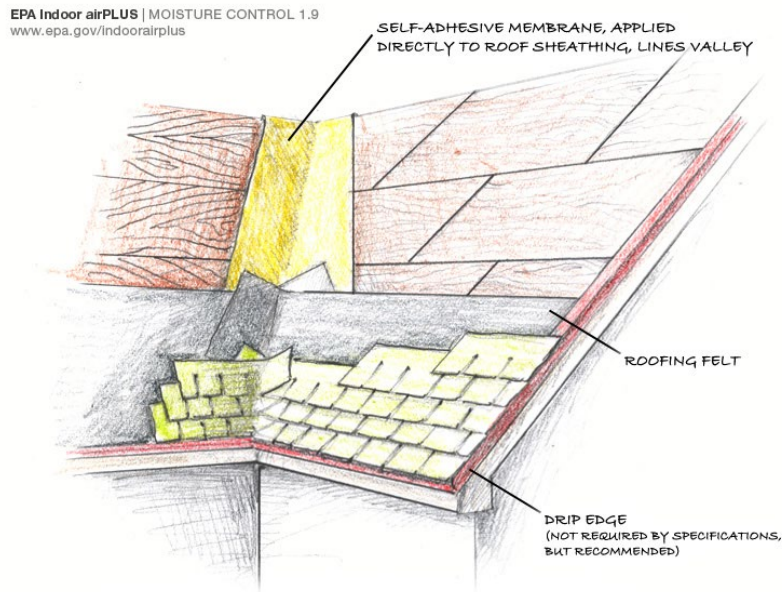

MEMBRANE PROTECTION OF ROOF VALLEY

Self-sealing membrane installed at roof valley

Image source: EPA Indoor airPLUS

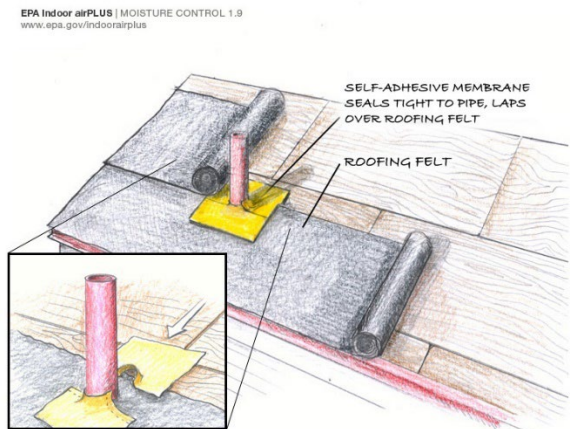

PLUMBING VENT STACK - 'PEEL AND STICK' MEMBRANE

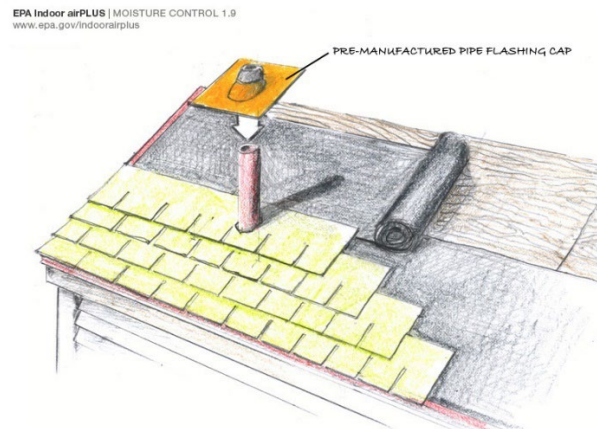

SHINGLES PLACED OVER MEMBRANE AND FELT

Roof penetrations flashed and integrated with shingles

DU 1.4.2. Step and kick-out flashing at wall/roof and wall/porch intersections, flashing $\geq 4"$ on wall surface and integrated with wall and roof/deck/porch drainage planes

- **Criteria:** Install step and kick-out flashing at all wall/roof and wall/porch intersections. Extend flashing $\geq 4"$ on the wall surface above the roof deck and integrate flashing with wall and roof drainage plans. Maintain at least a 2" exposure of step flashing once exterior cladding has been installed.



Step 1: Install roof underlayment (such as felt paper) over roof deck and up sidewall over housewrap



Step 2: Install shingle starter strip, then kick-out flashing. Secure to roof deck but not to sidewall



Step 3: Install first shingle and flashing over upper edge of diverter



Step 4: Install flashing, counter flashing and shingles



Step 5: Apply self-adhering flashing over top edge of step flashing, diverter and housewrap.



Step 6: Install next layer of housewrap to fit over top of diverter. Maintain at least a 2" exposure of step flashing.

Image Source: Dryflekt 2015

Roof step flashing should be integrated with kick-out flashing to ensure that water is effectively directed away from gutters and/or exterior walls to prevent bulk moisture damage to building framing members.

Additional Information:

- Step flashing and kick-off flashing resources may be found at:
 - <https://basc.pnnl.gov/resource-guides/step-and-kick-out-flashing-roof-wall-intersections#edit-group-description>
 - 2018 IRC, R903.2.1:
 - <https://up.codes/viewer/georgia/irc-2018/chapter/2/definitions#slope>
 - "Kickout flashing: Required by Code, Yet Often Overlooked," Guertin, Martin, Journal of Light Construction, October 24, 2019, https://www.jlconline.com/training-the-trades/kickout-flashing-required-by-code-yet-often-overlooked_o

- Roof valley membrane and roof penetration sealing resources may be found at:
 - <https://basc.pnnl.gov/resource-guides/roof-deck-valleys-and-penetrations-sealed#edit-group-description>

Clarifications:

- For metal and rubber membrane roofs, install continuous flashing in place of step flashing.
- For porches, install L-shaped flashing to the top of the ledger board and integrate with drainage plane (vertical leg of the flashing must extend along the wall above the ledger and the horizontal leg extends over the top of the ledger).

Verification:

- The EarthCraft Technical Advisor will determine compliance during mid-construction inspections through:
 - In-person field verification
 - The project team may illustrate compliance with criteria through photo documentation submitted to the EarthCraft Technical Advisor during mid-construction inspections

DU 1.5 Maintain 2" clearance between wall siding and roof surface (requirement)

Criteria: Terminate wall siding a minimum of a 2" above roof surface unless otherwise directed by product manufacturer installation specifications.

Additional Information:



Ensure a minimum 2" space is left between the siding or cladding material and roof, with flashing visible for necessary visual inspection.

Verification:

- The EarthCraft Technical Advisor will determine compliance during mid-construction inspections through:
 - In-person field verification
 - The project team may illustrate compliance with criteria through photo documentation submitted to the EarthCraft Technical Advisor during mid-construction inspections

DU 1.6 Install air conditioner condensing unit pad (requirement)

Criteria: Install condenser unit pad for all outdoor air-conditioner and heat pump condensing units.

Verification:

- The EarthCraft Technical Advisor will visually confirm compliance with criteria during mid-construction or final inspections through in-person verification

DU 1.7 Roof drip edge with $\geq 1/4$ " overhang (requirement)

Criteria: Protect the outer edge of all roof decking with a metal or plastic drip edge that has a minimum $1/4$ " overhang beyond the exterior roofing material.

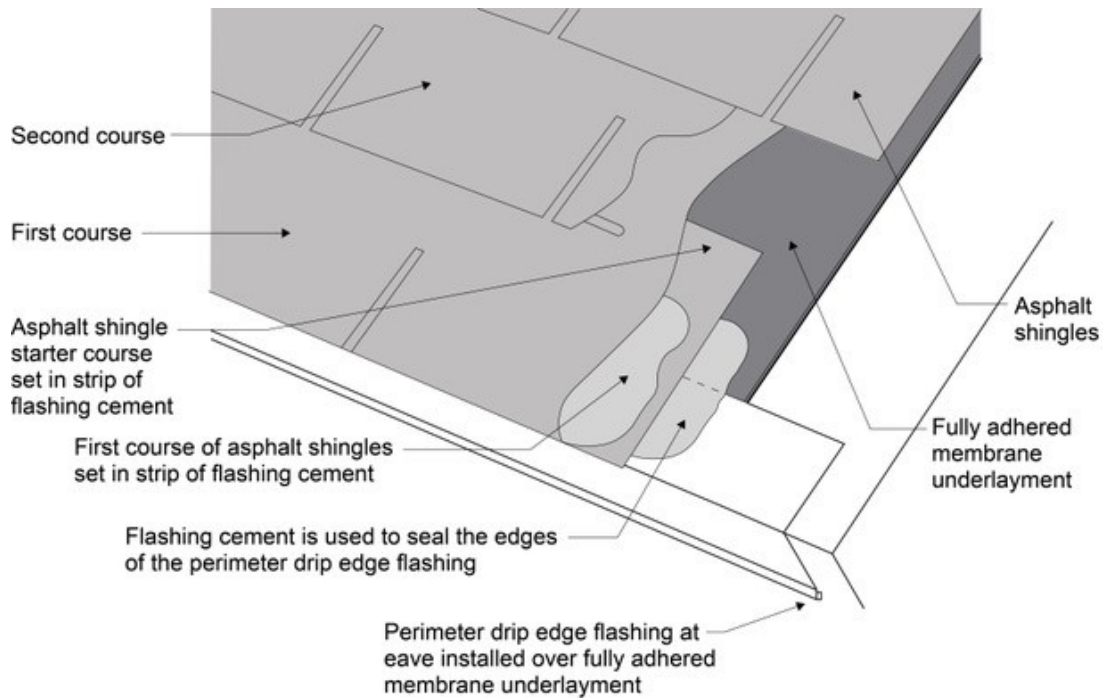

Verification:

- The EarthCraft Technical Advisor will determine compliance during mid-construction inspections through:
 - In-person field verification
 - The project team may illustrate compliance with criteria through photo documentation submitted to the EarthCraft Technical Advisor during mid-construction inspections

DU 1.8 Drain pan for water heaters and washing machines (requirement)

Criteria: Install an appropriately sized drain pan underneath all hot water heaters in above-grade units, and floor drains in water heater closets in ground floor or below-grade units.

Additional Information



Provide drain pans for all water heaters located in above grade units.

Verification:

- The EarthCraft Technical Advisor will visually confirm compliance with criteria at final inspections

DU 1.9 Enclosed crawlspace, if applicable to design (2 points)

Required for Platinum certification

Criteria: If installed, crawlspace must be closed. No vents are allowed. Crawlspace must be conditioned.

Additional Information:

Additional strategies required to meet this credit intent include but are not limited to:

- DU 2.5 100% coverage of ≥ 6 mil vapor barrier in crawlspace or beneath slab
- DU 2.14 Capillary break
- IAQ 1.1 Sealed-combustion furnace or isolate furnace from conditioned space
- IAQ 1.2 Sealed-combustion, power vent or electric water heater, or isolate water heater from conditioned space
- BE 1.5 Seal penetrations through
- BE 1.9 Install weather stripping at all exterior doors
- BE 3.14 Seal and insulate crawlspace walls

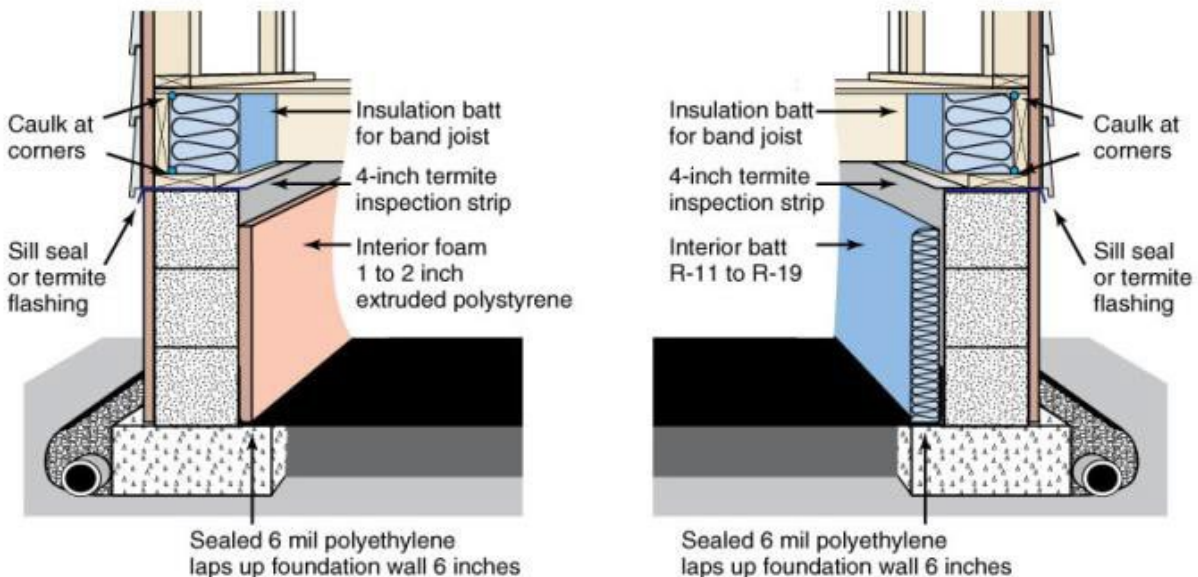

Options for designing a closed crawlspace

Additional resources may be found at:

- Building America Solution Center: <https://basc.pnnl.gov/resource-guides/unvented-insulated-crawlspaces>
- Advanced Energy: <https://www.advancedenergy.org/crawlspaces/>

Clarifications:

- Projects built in 100-year flood plains are not eligible to earn this credit.
- Drainage, pests and combustion safety issues are important considerations when sealing a crawlspace.
- Conditioning strategies may involve one of the following methods:
 - Continuously operated mechanical exhaust ventilation at a rate of 1 cfm for each 50 square foot of crawlspace floor area including a make-up air pathway to the main living area such as a transfer grill.
 - Conditioned air supply (e.g., via supply duct) sized to deliver a rate of 1 cfm for each 50 square foot of crawlspace area.
 - **DU2**.17.B. Additional dehumidification system: Basement or sealed crawlspace system

Verification:

- The EarthCraft Technical Advisor will visually confirm compliance with criteria at mid-construction and final inspections.

DU 1.10 Moisture-resistant wallboard in kitchen, bathroom(s), and laundry, if applicable to project scope (2 points)

Required for Platinum certification

Criteria: Install cement board, fiberglass enhanced sheathing or equivalent moisture-resistant backing material on walls behind bathroom sinks, and tubs and showers with tile or panel assemblies with caulked joints. Install moisture-resistant backing material in accordance with manufacturer specifications.

Moisture-resistant gypsum board must be installed on exposed walls and ceilings above tubs and showers where the wall is not covered by tile or a panel assembly.

Moisture-resistant gypsum board must be installed on exposed walls behind bathroom sinks and kitchen sinks when the wall is not covered by tile or other water-resistant splash back assemblies.

This credit is a requirement for projects pursuing the Platinum Level of EarthCraft Multifamily certification

Clarifications:

- Drywall products tested and manufactured to meet ASTM D3273, Standard Test Method for Resistance to Growth of Mold on the Surface of Interior Coatings in Environmental Chamber, meet the criteria for this credit

Verification:

- The EarthCraft Technical Advisor will visually confirm compliance with criteria during mid-construction inspections.

DU 1.11 Vented rain screen behind exterior cladding (3 points)

Criteria: All exterior wall area installed with a weather-resistive barrier such as building paper, house-wrap or similar material designed to protect the wall from water moving past the exterior cladding and have an air space of at least 3/8" between the exterior cladding and weather-resistive barrier.

Additional Information:

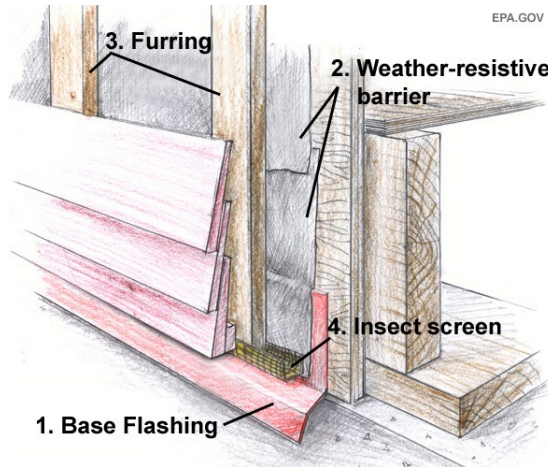

Wood furring strips spaced every 16-24 inches installed to provide a minimum 3/8 inch thick air space between siding material and drainage plane.

Image Source: EPA Indoor airPLUS

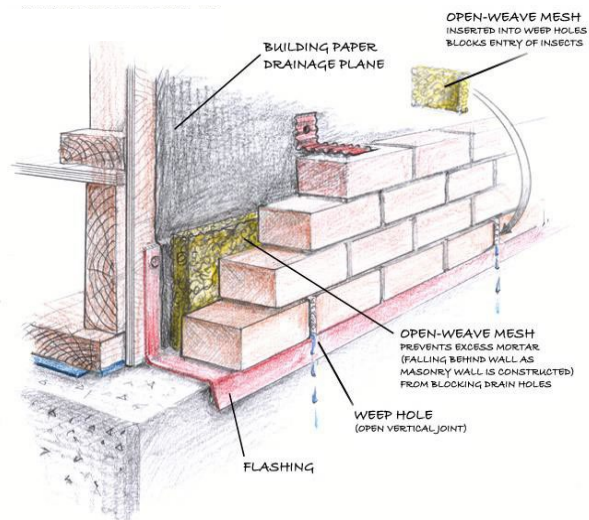

Air space behind brick veneer allows for proper water movement between the back of the brick and exterior drainage plane. Open weave mesh installed at the weep holes prevent excess mortar from blocking the holes and preventing water from draining.

Image Source: EPA Indoor airPLUS

The system must be integrated with flashing and be designed and installed to minimize moisture migration between the exterior cladding and the wall sheathing.

Additional resources may be found at:

- Building America Solution Center: <https://basc.pnnl.gov/resource-guides/flashing-bottom-exterior-walls#edit-group-description>

Clarifications:

- If installing masonry veneer, install full-head weep holes with a minimum 24" on center spacing.

Verification:

- The EarthCraft Technical Advisor will determine compliance during mid-construction inspections through:
 - In-person field verification
 - The project team may illustrate compliance with criteria through photo documentation submitted to the EarthCraft Technical Advisor during mid-construction inspections

DU 1.12 Flashing at bottom of exterior walls integrated with foundation drainage system (2 points)

Criteria: Install flashing at the bottom of exterior walls integrated with drainage system.

This credit is a requirement for projects pursuing the Platinum Level of EarthCraft Multifamily certification

Additional Information:

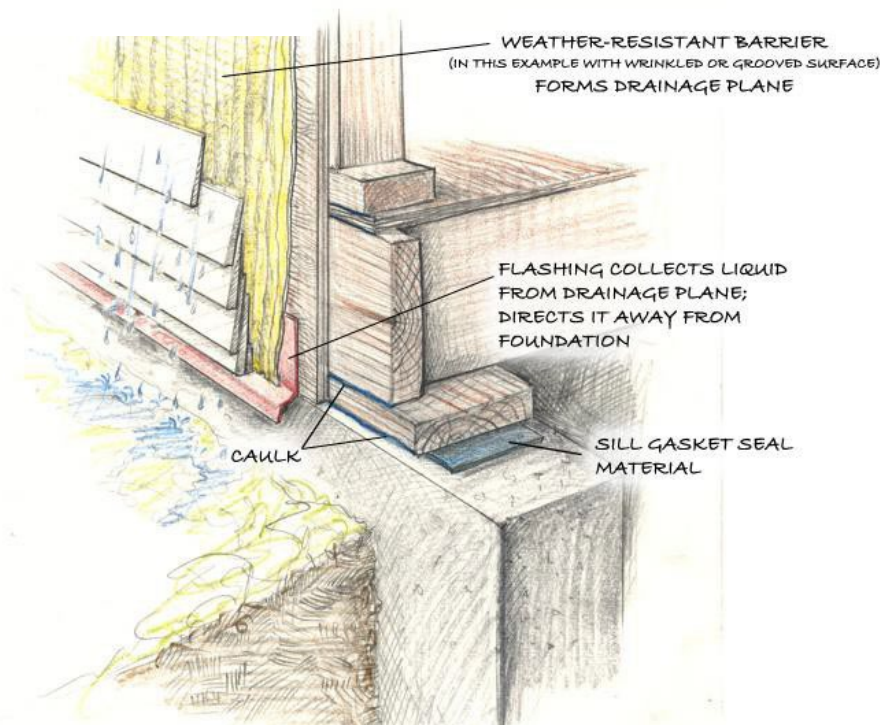

Flashing shall be installed at the bottom of the wall system and integrated with the primary drainage plane behind the cladding.

Image Credit: EPA Indoor airPLUS

Clarifications:

- If masonry veneer is installed, install full-head weep holes with a minimum 24" on center spacing or equivalent drainage system.

Verification:

- The EarthCraft Technical Advisor will determine compliance during mid-construction inspections through:
 - In-person field verification
 - The project team may illustrate compliance with criteria through photo documentation submitted to the EarthCraft Technical Advisor during mid-construction inspections

DU 1.13 Alternative termite control with no soil pre-treatment (2 points)

Criteria: Install an alternative termite control system that does not include chemical soil pre-treatment. Provide information on type of system, maintenance, and monitoring requirements in project-specific owner's manual.

Additional Information:

Alternative termite treatments include:

- Non-chemical methods include treating wood building materials used at the foundation and in contact with the foundation with a borate-based product
- Termite bait systems installed onsite per manufacturer specifications

Verification:

- The EarthCraft Technical Advisor will visually confirm compliance with criteria during mid-construction and/or final inspections.

DU 1.14 Non-toxic lumber treatment

Criteria: Treat wood building materials to prevent pest and/or mold growth in all wood building framing materials.

There are multiple options available for certification credits. Projects may achieve points for one or all options.

DU1.14.1. All lumber in contact with foundation (≥36" above foundation) (1 point)

- **Criteria:** Pre-treat all lumber in contact with the foundation with a non-toxic pest treatment such as borate. Lumber must be treated to a minimum height of 3' above the foundation.

DU 1.14.2. All lumber (2 points)

- **Criteria:** Pre-treat all lumber with a non-toxic pest treatment such as borate.

DU 1.14.3. Mold inhibitor with warranty applied to lumber (1 point)

- **Criteria:** Apply a non-toxic mold inhibitor with warranty to all lumber.

Verification:

- The EarthCraft Technical Advisor will visually confirm compliance with criteria during mid-construction inspections.
- Documentation will be provided demonstrating compliance with all treatment options selected.

DU 1.15 Exterior cladding (≥75% facade) with 30-year warranty (2 points)

Criteria: Install exterior wall cladding with a 30-year manufacturer's warranty or constructed from durable natural material, such as masonry, stucco, stone, or brick on a minimum of three sides of the building.

Verification:

- The EarthCraft Technical Advisor will visually confirm compliance with criteria during mid-construction inspections.
- Documentation will be provided demonstrating compliance

DU 1.16 Windows, doors, and skylights with ≥25-year warranty (1 point)

Criteria: All installed exterior windows, doors and skylight assemblies must have ≥25-year manufacturer's warranty.

Verification:

- The EarthCraft Technical Advisor will visually confirm compliance with criteria during mid-construction inspections.
- Documentation will be provided demonstrating compliance for all assemblies.

DU 1.18 Roofing warranty

Criteria: Install new singles or roofing materials with a 40- or 50-year warranty.

There are multiple options available for certification credits. Projects may achieve points for only one option.

DU 1.18.A. 40-year warranty (1 point)

Install shingles or other exterior roofing material that have ≥40 year manufacturer's warranty.

DU 1.18.B. 50-year warranty (2 points)

Install shingles or other exterior roofing material that have ≥50 year manufacturer's warranty.

Verification:

- The EarthCraft Technical Advisor will visually confirm compliance with criteria during mid-construction and final inspections.
- The EarthCraft Technical Advisor will review documentation provided by the project team for compliance with criteria.

DU 1.19 Drain pan for clothes washers (1 point)

Criteria: Install clothes washer drain pans for in-unit laundry rooms.

Clarifications:

- Projects may achieve this credit even if they are not providing the clothes washer and dryer appliances, but they are providing an in-unit laundry closet with hook-ups for clothes washers and dryers.

Verification:

- The EarthCraft Technical Advisor will visually confirm compliance with criteria during final inspections.

DU 2: Moisture Management

The second section of Durability & Moisture Management, DU 2: Moisture Management, focuses on building design and construction practices that control bulk water intrusion and water vapor management.

DU 2.0 100% coverage of ≥ 12 mil vapor barrier in crawlspace (requirement)

Criteria: Install continuous ≥ 12 mil, Class I vapor barrier over all exposed earth in crawlspaces. This is a requirement for all projects.

- Provide 100% coverage.
- Overlap all vapor barrier joints a minimum of 6 inches and seal joints using appropriate sealant.
- Extend and seal edges of vapor barrier at least 6 inches up the foundation wall, piers and above exterior ground grade level.

Additional Information:

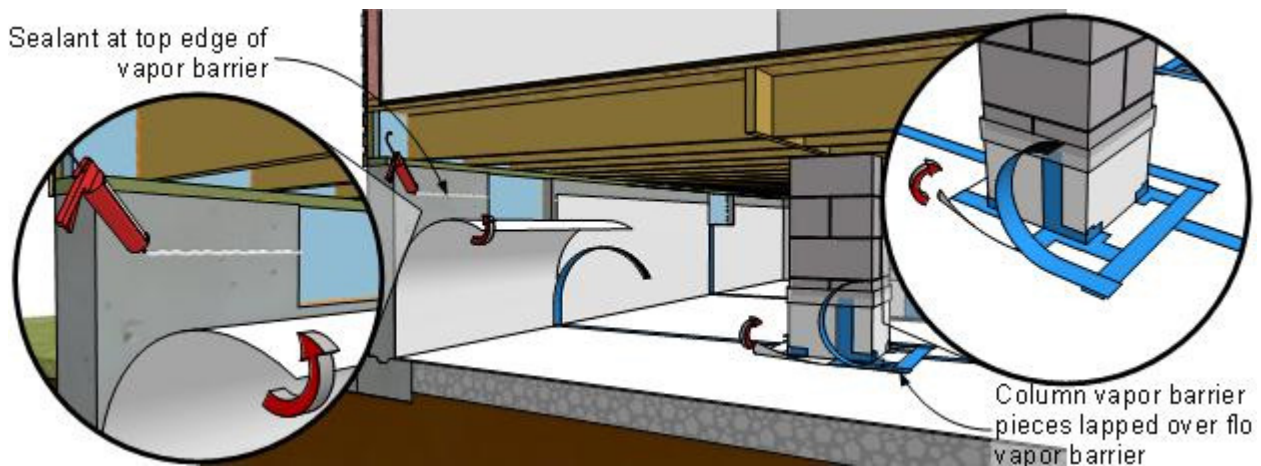

Vapor barriers should be installed using ≥ 12 mil plastic that covers 100% of exposed dirt. The plastic shall be sealed to the foundation walls and piers at least 6 inches above grade using an appropriate sealant and/or mechanical fastener. All plastic seams shall overlap a minimum of 6" and be sealed.

Image credit: IBACOS, Building America Solution Center

Additional information may be found at:

- Building America Solution Center: <https://basc.pnnl.gov/resource-guides/capillary-break-crawlspace-floors-polyethylene-lapped-walls-and-piers-or-secured>
- No polyethylene or other materials with a perm rating ≤ 0.1 , such as vinyl wallpaper, may be used on below- or above-grade walls of conditioned space, or in any other assembly except under slabs and on crawlspace floors. This is a requirement for all projects.

Verification:

- The EarthCraft Technical Advisor will visually confirm compliance with criteria during mid-construction and final inspections.

DU 2.1 Patio slabs, walks and driveways sloped $\geq 1/4$ inches per 1 foot away from the building foundation for ≥ 10 feet or to the edge of the surface, whichever is less (requirement)

Criteria: Slope new patio slabs, porch slabs, walks and/or driveways a minimum of $1/4$ inches per 1 foot away from the building over a minimum distance of 10 feet, or to the end of the slabs, walks and driveways for areas less than 10' wide. This is a requirement for all projects.

- Tamp back-fill to prevent settling under patio slabs, walks and driveways unless proper drainage can be achieved using non-settling compact soils, as determined by a certified hydrologist, soil scientist or engineer.

Clarifications:

- Where setbacks limit space to less than 10 feet, install swales or drains designed to carry water away from the foundation.

Verification:

- The EarthCraft Technical Advisor will visually confirm compliance with criteria during mid-construction and final inspections.

DU 2.2 Vapor barrier installed under slabs (if applicable) and in crawlspaces only and not on vertical surfaces (requirement)

Criteria: Install a ≥ 6 mil vapor barrier beneath all new slabs to prevent soil moisture and gases from entering. Provide 100% coverage. Overlap all vapor barrier joints a minimum of 6". Install vapor barrier in new or existing crawlspaces to meet DU 2.0. This is a requirement for all projects.

Clarifications:

- No polyethylene or other materials with a perm rating ≤ 0.1 , such as vinyl wallpaper, may be used on below- or above-grade walls of conditioned space, or in any other assembly except under slabs and on crawlspace floors. This is a requirement for all projects.

Verification:

- The EarthCraft Technical Advisor will visually confirm compliance with criteria during mid-construction inspections.
- The EarthCraft Technical Advisor will review documentation provided by the project team for compliance with criteria.

DU 2.3 Final site grade sloped $\geq 1/2$ inch per 1 foot away from the building foundation for ≥ 10 feet or to the edge of the site, whichever is less (requirement)

Criteria: Slope final site grade away from the foundation at a rate of $1/2''$ per 1 foot over a minimum distance of 10 feet.

- Tamp back-fill to prevent settling unless proper drainage can be achieved using non-settling compact soils, as determined by a certified hydrologist, soil scientist, or engineer.

Clarifications:

- Where setbacks limit space to less than 10 feet, install swales or drains designed to carry water away from the foundation.

Verification:

- The EarthCraft Technical Advisor will visually confirm compliance with criteria during mid-construction and final inspections.

DU 2.4 Existing building materials removed/cleaned within 2 feet minimum radius of water damage (requirement)

Criteria: Where water damaged building materials are present, after repairing source of water intrusion or leak remove damaged materials within a 2' radius of source. Do not install building materials that have visible signs of water damage or mold. This is a requirement for all projects.

Clarifications:

- If the framing members or in insulation has high moisture content (framing members should be dried to at least 18% moisture content), do not enclose interior walls.
- Follow the manufacturer's drying recommendations for wet-applied insulation and test framing members for moisture prior to enclosing wall cavities.

Verification:

- The EarthCraft Technical Advisor will visually confirm compliance with criteria during mid-construction inspections.
- If high moisture was present:
 - The project team must present documentation demonstrating compliance with criteria to the EarthCraft Technical Advisor during mid-construction inspections.
 - The EarthCraft Technical Advisor will review documentation provided by the project team for compliance with criteria.

DU 2.5 Existing vapor barriers on vertical surfaces removed or remediated based on EarthCraft approval (requirement)

Criteria: Remove existing vapor barrier material(s) installed in the walls, floors, and/or ceilings of the insulated building envelope. Evaluate building envelope during pre-construction assessment to determine presence of vapor barrier and, if necessary, determine plan to remove material(s) during construction.

Additional Information:

- No polyethylene or other materials with a perm rating ≤ 0.1 , such as vinyl wallpaper, may be used on below- or above-grade walls of conditioned space, or in any other assembly except under slabs and on crawlspace floors. This is a requirement for all projects.

Verification:

- The EarthCraft Technical Advisor will visually confirm compliance with criteria during mid-construction inspections.
- The EarthCraft Technical Advisor will review documentation provided by the project team for compliance with criteria.

DU 2.6 Drainage board and damp proofing for below-grade walls (requirement)

Criteria: Apply damp proofing and install a drainage plane material that channels water down to the footing drain tile for all below-grade walls. This is a requirement for all projects.

Clarifications:

- Wood-framed below-grade walls are not allowed along the exterior of the building
- Do not install Class I vapor retarders on the interior side of air permeable insulation in exterior below-grade walls, except for tile at showers and tub walls.
- Mirrors may be used if they are mounted with clips or other spacers that allow air to circulate behind them.

Verification:

- The project team must present documentation demonstrating compliance with criteria to the EarthCraft Technical Advisor during mid-construction inspections.
- The EarthCraft Technical Advisor will review documentation provided by the project team for compliance with criteria.

DU 2.7 Foundation drain at outside perimeter edge of footing surrounded with 6" clean gravel and fabric filter (2 points)

Required for Platinum and Gold certification

Criteria: Install a protected foundation drain tile so that the top of the drain tile pipe is below the bottom of the concrete slab or crawlspace floor, or alongside the outside perimeter edge of the footing, whichever is lower. This credit is required for projects seeking Platinum and Gold level certification.

Additional details include:

- Use appropriate drain elbows for bends to prevent drainage constriction around corners or use an EarthCraft-approved product that meets the same intent.
- Surround each pipe with at least 6" of 1/2" to 3/4" gravel. Wrap gravel layer fully with fabric cloth.
- Discharge all drain lines either away and downhill from the foundation to outside grade/daylight or to a sump

Additional Resources:

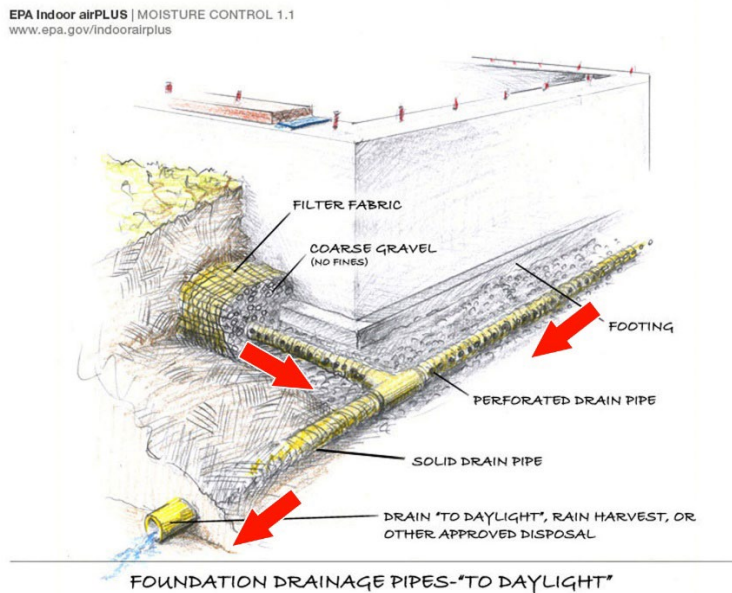
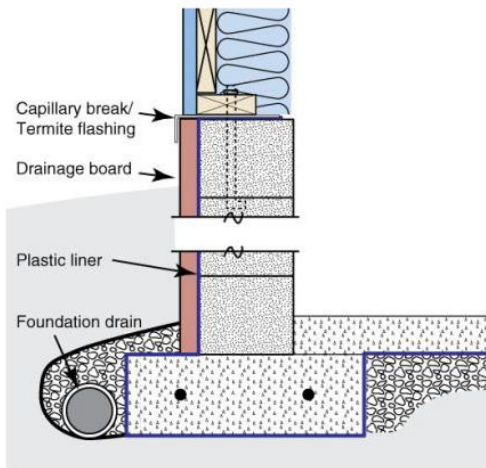

Foundation drain should be installed level with the bottom of the foundation footing.

Image Sources: Building America Solution Center (left) and EPA Indoor AirPLUS (right)

Additional information may be found at:

- Building America Solution Center: <https://basc.pnnl.gov/resource-guides/footing-drain-pipe#edit-group-scope>

Clarifications:

If radon-resistant features are installed and are incorporated into the foundation drainage system which discharges to daylight, a check valve must be installed at the drain tile outfall.

Verification:

- The project team must present documentation demonstrating compliance with criteria to the EarthCraft Technical Advisor during mid-construction inspections.
- The EarthCraft Technical Advisor will review documentation provided by the project team for compliance with criteria.

DU 2.8 Dedicated dehumidification system in basement and/or closed crawlspace areas (2 points)**Required for Platinum and Gold certification**

Criteria: Install a dedicated dehumidification system for basement(s) and/or closed crawlspace.

Additional Information:

- Dehumidification should be sized to provide 70 pints of moisture removal per day for every 1,000 ft² of crawlspace floor area.
- Closed crawlspace must meet the requirements of DU 1.10

Verification

- The EarthCraft Technical Advisor will visually confirm compliance with criteria during mid-construction and final inspections.

DU 2.9 Design for or install additional dehumidification**Required for Platinum and Gold certification**

Criteria: Install supplemental dehumidification for living spaces.

There are multiple options available for certification credits. Projects may achieve points for only one option.

DU 2.12.A Rough-in electrical and plumbing for whole-unit dehumidifier (2 points)

- **Criteria:** Design HVAC closet to include:
 - Framing for in-wall dehumidifier or space within closet/room for a ducted dehumidifier. If plan is to use a ducted dehumidifier, provide plans and specifications for future ducting.
 - Dedicated, labeled electrical outlet within HVAC closet for dehumidifier capable of providing 70 pints of moisture removal per day for every 1,000 ft² of unit floor area.
 - Ensure drain used for HVAC condensate line is large enough for future dehumidifier drain line.

DU 2.12.B Install whole-house ENERGY STAR dehumidifier with pump and drain to exterior (5 points)

- **Criteria:** Install a whole-house ENERGY STAR dehumidifier with pump and drain line connected to HVAC condensation line or drain

Clarifications:

- A stand-alone dehumidifier located near a central return with drain line connected to the HVAC condensate pump may qualify to meet the criteria. Plan should be approved by EarthCraft Technical Advisor prior to installation to ensure intent is met.
- As products and ENERGY STAR qualifications are periodically updated, the product must be on the list of ENERGY STAR-qualified products at the time it was purchased.

Verification:

- The project team must present documentation demonstrating compliance with criteria to the EarthCraft Technical Advisor during the design review meeting
- The EarthCraft Technical Advisor will review documentation provided by the project team for compliance with criteria.
- The EarthCraft Technical Advisor will verify installation of system during final inspections.

DU 2.10 Humidistat or thermostad used with whole-house variable speed cooling system (2 points)

Criteria: Install a humidistat or thermostat used with an air handler equipped with a central variable speed blower on all heating and cooling equipment for moisture removal. System must provide supply and return air pathways to the HVAC system.

Clarifications:

- Equipment must be installed to maintain relative humidity levels $\leq 60\%$ relative humidity.
- Systems designed for whole-house dehumidification of the main living space should take the points available in DU 2.12.

Verification:

- The EarthCraft Technical Advisor will visually confirm compliance with criteria during final inspections.

Indoor Air Quality (IAQ)

Because the average American spends over 90% of their time indoors, creating a healthy and comfortable indoor environment is an important issue for any resident, especially those who are more sensitive to air quality such as children, seniors, and individuals with respiratory problems and compromised immune systems. Contractors can create a healthier indoor environment by installing materials with fewer pollutants, flushing any pollutants out through proper ventilation, and controlling moisture to eliminate mold growth.

The Indoor Air Quality category consists of items that aim to reduce the presence of pollutants and contaminants in the air inside a building. Reducing or eliminating the presence of manmade pollutants such as volatile organic compounds or natural occurring carcinogens such as radon leads to a healthier environment for occupants.

IAQ 1: Combustion Safety

The first section of Indoor Air Quality covers combustion safety considerations for the design and construction of units, and the installation of combustion appliances within occupied spaces.

IAQ 1.0 No unvented combustion fireplaces, appliances, or space heaters (requirement)

Criteria: Do not install new unvented combustion space-heating appliances. Remove any existing unvented space heating appliances. If they are to be replaced, install sealed combustion appliances. This is a requirement for all projects.

Clarifications:

- Vent all combustion fireplaces and appliances to remove combustion products as well as process fumes to the outside air.
- All fireplaces must provide dedicated combustion air inlets that pull air directly from the outdoors.

Verification:

- The EarthCraft Technical Advisor will confirm presence of existing unvented appliances and confirm with project team if they are to be removed or replaced.
- The EarthCraft Technical Advisor will visually confirm compliance with criteria during mid-construction and final inspections.

IAQ 1.1 All gas furnaces are sealed-combustion appliances (requirement)

Criteria: Gas space heating equipment must be sealed combustion. This is a requirement for all projects.

Clarifications:

- If existing furnaces are $\leq 80\%$ Annual Fuel Utilization Efficiency (AFUE), have an open combustion chamber/use living space air for combustion, and/or exhaust their combustion air into the living space or other adjacent unconditioned space they must be replaced with sealed combustion systems.
- Sealed combustion appliances must be equipped with a sealed combustion chamber, intake flue/vent that pulls combustion air directly from the outdoors, and exhaust flue that discharges gases directly to the exterior.
- EarthCraft requires high efficiency sealed combustion furnaces. These systems require PVC or other non-corrosive vent pipe to remove combustion gases and condensation to the exterior.
- Even if the manufacturer allows combustion air to be provided by an attic or other unconditioned space, EarthCraft requires all gas furnace combustion air intake to come directly from the exterior. Provide combustion air from outside the building in compliance with the mechanical code and manufacturer specifications for size of pipe and location of intake at the exterior of the building.

Verification:

- The EarthCraft Technical Advisor will visually confirm compliance with criteria during the design review phase, mid-construction, and final inspections.

IAQ 1.2 Sealed-combustion, direct vent or power vent gas water heater(s) (requirement)

Criteria: Install gas water heater that has direct venting or power venting if located within residential units, within conditioned space, or in closets that share a wall with conditioned space. This is a requirement for all projects.

Clarifications:

- If existing water heaters have an open combustion chamber/use living space air for combustion, and/or exhaust their combustion air into the living space or other adjacent unconditioned space they must be replaced with sealed combustion systems.
- Direct vent appliances must provide combustion air from outside the building in compliance with the mechanical code and manufacturer specifications
- Power vent appliances must be installed in spaces that provide appropriate combustion air meeting the mechanical code and manufacturer specifications.

Verification:

- The EarthCraft Technical Advisor will visually confirm compliance with criteria during the design review phase, mid-construction, and final inspections.

IAQ 1.3 All fireplaces have outdoor combustion air supply and gasketed doors (requirement)

Criteria: Design and install all fireplaces to provide outdoor air supply for combustion. This is a requirement for all projects in all residential and common spaces.

Clarifications:

- Existing fireplaces must be updated to meet criteria or removed/sealed to prevent future use.
- All fireplaces must use a supply duct supplying outside air for combustion that complies with the fire code.
- Fireplaces must have gasketed doors.

Verification:

- The EarthCraft Technical Advisor will visually confirm compliance with criteria during mid-construction and final inspections.

IAQ 1.4 Carbon monoxide detector in all residential units (requirement)

Criteria: Install one carbon monoxide (CO) detector per unit, even if the unit has no garage or combustion appliances. This is a requirement for all projects.

Clarifications:

- All detectors must be hardwired with a battery backup.
- Combination smoke/CO detectors meet the intent provided they are certified by CSA 6.19-01 or UL 2034.

Verification:

- The EarthCraft Technical Advisor will visually confirm compliance with criteria during mid-construction and final inspections.

IAQ 1.5: Combustion Appliance Zone testing performed on a sample of existing occupied units with gas appliances (requirement)

Criteria: Perform combustion safety testing on existing combustion appliances that are to remain active within occupied units during pre-construction and construction activities. This is a requirement for all projects.

Additional Information:

- Combustion safety testing must be done in accordance with one of the following:
 - ANSI/BPI-1200-S-2017 Standard Practice for Basic Analysis of Buildings
 - RESNET Mortgage Industry National Home Energy Rating Systems (MINHERS) Chapter 8

Clarifications:

- Testing is required on occupied units with active combustion appliances. If these conditions exist during consecutive days when the building envelope and/or appliances are changed (including but not limited to the completion of air sealing or replacement of combustion vents), combustion safety testing must be completed at the end of the workday to ensure that occupants are not exposed to carbon monoxide or other harmful combustion byproducts.
- Testing must be completed by a certified HERS Rater, BPI Building Analyst – Professional, BPI Energy Auditor or BPI Quality Control Inspector.

Verification:

- The EarthCraft Technical Advisor will be responsible for determining when units and appliances require combustion safety testing.
- The EarthCraft Technical Advisor will be responsible for maintaining all test results and reporting testing that fails to the project site supervisor and or property manager.

IAQ 2: Indoor Pollutant Control

The second Indoor Air Quality section, IAQ 2: Indoor Pollutant Control, provides requirements and credit items for interior finishes and appliances that minimize occupant exposure to known indoor pollutants and irritants.

IAQ 2.0 Protect all ducts in floors and open returns until floor finishing is complete (requirement)

Criteria: All ducts in floors (return or supply) and all open returns must be protected to prevent construction debris from entering ductwork. This is a requirement for all projects. Additionally:

- Existing ductwork that is to remain shall be cleaned of existing debris prior to air sealing and prior to installing protective covering.
- The systems should either not be run until finished floor material(s) have been installed and/or pleated filters should be required upon early startup.
- New filters shall be installed prior to project close-out/move-in of residents.

Verification:

- The EarthCraft Technical Advisor will visually confirm compliance with criteria during mid-construction and final inspections.

IAQ 2.1 Filter is easily accessible for maintenance (requirement)

Criteria: Install all filters in an easily accessible location. Easily accessible is defined as any location which facilitates access and regular filter changes by future occupant. This is a requirement for all projects.

Clarifications:

- Filters located within the units (e.g., at the return grill) are also considered easily accessible.
- Filters located at the return within an HVAC closet are considered easily accessible.
- Filters perform best when the filter rack design includes flexible, airtight (e.g., closed-cell foam) gasket material on the downstream side of the filter and friction fit or spring clips installed on the upstream side of the filter.
- Non-standard efficiency ratings for filters (e.g., 3M's Microparticle Performance Rating [MPR]) and filters that do not have a MERV rating (e.g., electrostatic filters) need prior approval by EarthCraft.
- Filter doors should not be obstructed by any permanent fixtures including water heaters, washer and dryers, vents, condensate line or refrigerant line sets.
- HVAC system design and installation must ensure accessible criteria are met.

Verification:

- The EarthCraft Technical Advisor will visually confirm compliance with criteria during mid-construction and final inspections.

IAQ 2.2 Provide rodent and corrosion proof screens with mesh ≤0.5" for all openings not fully sealed or caulked (requirement)

Criteria: Install corrosion-proof rodent/bird screens (e.g., copper, or stainless steel) with a mesh 0.5 inches or smaller on all building openings, such as ventilation system intake/exhaust outlets and attic/crawl space vent openings that cannot be fully sealed or caulked. This is a requirement for all projects

Clarifications:

- Clothes dryer vents should use a flap damper to prevent rodent entry.

Verification:

- The EarthCraft Technical Advisor will visually confirm compliance with criteria during mid-construction and final inspections.

IAQ 2.3 All interior paints have <50g/L VOC content (requirement)

Criteria: Use only interior paints with a VOC content of <50g/L for common areas and for all residential units and indoor common spaces. This is a requirement for all projects.

Verification:

- The EarthCraft Technical Advisor will visually confirm compliance with criteria during final inspections.
- The EarthCraft Technical Advisor will review product documentation provided by the project team.

IAQ 2.4 GREENGUARD Certified materials

Required for Platinum certification

Criteria: Install interior finishes that are UL GREENGUARD certified as being low- or no-Volatile Organic Compound (VOC) containing materials. There are multiple point options available in this credit. Projects may seek all or one of the point options.

IAQ 2.4.1. Interior paints (1 point)

IAQ 2.4.2. Stains and finishes on wood floors (2 points)

IAQ 2.4.3. Sealants and adhesives (2 points)

IAQ 2.4.4. Carpet (1 point)

IAQ 2.4.5. Carpet pad (1 point)

IAQ 2.4.6. Carpet pad adhesive (2 points)

IAQ 2.4.7. Insulation (2 points)

IAQ 2.4.8. Kitchen and bathroom cabinets (1 point)

IAQ 2.4.9. Laminate or wood composite countertops (1 point)

Additional Information:

- Current GREENGUARD information on standards may be found at:
<https://www.ul.com/services/ul-greenguard-certification>

Verification:

- The project team must present documentation demonstrating compliance with criteria to the EarthCraft Technical Advisor at the final inspection.
- The EarthCraft Technical Advisor will review documentation provided by the project team for compliance with criteria.

IAQ 2.5 Protect ducts until construction is completed (2 points)**Required for Platinum certification**

Criteria: Seal all supply and return duct openings to stop construction trash and dust from contaminating new duct system, and keep ducts sealed for the duration of construction. This is a requirement for projects seeking Platinum level certification.

Clarifications:

- Existing ductwork that is to remain shall be cleaned of existing debris prior to air sealing and prior to installing protectant covering.
- The systems should either not be run until finished floor installed and/or pleated filters should be required upon early startup with a filter change halfway between startup and certificate of occupancy (CO).

Verification:

- The EarthCraft Technical Advisor will visually confirm compliance with criteria during mid-construction and final inspections.

IAQ 2.6 Protect all bath fans until construction is completed (1 point)**Required for Platinum certification**

Criteria: Upon installation of all bath fans, seal all chases and openings to stop construction trash and dust from contaminating bath fan systems, and keep fans protected for the duration of construction. This is a requirement for projects seeking Platinum certification.

Verification:

- The EarthCraft Technical Advisor will visually confirm compliance with criteria during mid-construction and final inspections.

IAQ 2.7 No added urea-formaldehyde

Criteria: Install materials that are not manufactured using urea-formaldehyde. There are multiple point options available in this credit. Projects may seek all or one of the point options.

IAQ 2.7.1. Subfloor (1 point)

IAQ 2.7.2 Insulation (1 point)

IAQ 2.7.3. Kitchen and bathroom cabinets (1 point)

IAQ 2.7.4. Laminate or wood composite countertops (1 point)

IAW 2.7.5. Permanently installed wood shelving (1 point)

Clarifications:

- Points are only eligible for new and/or replacement materials or components installed as part of the scope of work for the project.

Verification:

- Project team will provide manufacturer information or material data sheets on specified materials for points
- Technical Advisor shall review and maintain documentation for all materials eligible for points.

IAQ 2.8 GREENGUARD Gold Certified materials

Criteria: Install interior finishes that are UL GREENGUARD Gold certified as being low- or no-Volatile Organic Compound (VOC) containing materials. There are multiple point options available in this credit. Projects may seek all or one of the point options.

IAQ 2.4.1. Interior paints (2 point)

IAQ 2.4.2. Stains and finishes on wood floors (3 points)

IAQ 2.4.3. Sealants and adhesives (3 points)

IAQ 2.4.4. Carpet (2 point)

IAQ 2.4.5. Carpet pad (2 point)

IAQ 2.4.6. Carpet pad adhesive (3 points)

IAQ 2.4.7. Insulation (3 points)

IAQ 2.4.8. Kitchen and bathroom cabinets (2 point)

IAQ 2.4.9. Laminate or wood composite countertops (2 point)

Additional Information:

- Current GREENGUARD Gold information on standards may be found at:
<https://www.ul.com/services/ul-greenguard-certification>

Verification:

- The project team must present documentation demonstrating compliance with criteria to the EarthCraft Technical Advisor at the final inspection.
- The EarthCraft Technical Advisor will review documentation provided by the project team for compliance with criteria.

IAQ 2.9 Seal all particle board surfaces with water-based sealant (1 point)

Criteria: Seal all particle board surfaces by coating all unsealed sides with water-based polyurethane sealant or a formaldehyde-free sealant. Sealant must have a VOC (volatile organic compounds) content of 200 g/L or less.

Additional Information:

Resources on sourcing low-VOC and formaldehyde products may be found at:

- Green Building Supply: <https://www.greenbuildingsupply.com/>
- UL SPOT: <https://spot.ul.com/>

Verification:

- The Technical Advisor will inspect for material compliance during mid-construction inspections.
- The EarthCraft Technical Advisor will review documentation provided by the project team for compliance with criteria.

IAQ 2.10 No carpet in all units (3 points)

Criteria: Do not install carpet in residential units on any floor.

Verification:

- The EarthCraft Technical Advisor will visually confirm compliance with criteria during final inspections.

IAQ 2.11 Limit carpet installation

Criteria: Limit carpet installation in residential units. There are multiple credit options available. Projects may achieve credits for one or both options.

IAQ 2.11.1. Main living area of all units (1 point)

Remove existing carpet and/or do not install new carpet in main living area of all units including areas adjacent to unit entrances.

IAQ 2.11.2. No carpet installed in below grade units (2 points)

Remove existing carpet and/or do not install new carpet in entire unit for below grade units.

Clarifications:

- If the project already achieves IAQ 2.10 No carpet in all units, the additional points in this credit may not also be awarded.

Verification:

- The EarthCraft Technical Advisor will visually confirm compliance with criteria during final inspections.

IAQ 2.12 Install permanent walk-off mats at each building entry (1 point)

Criteria: Install a built-in walk-off mat at each entry to the building from the exterior.

Clarifications:

- Walk off-mats must be at least 2 feet in length and allow accessibility for cleaning (e.g., grating with catch basin).

Verification:

- The EarthCraft Technical Advisor will visually confirm compliance with criteria during final inspections.

IAQ 2.13 Flush residential units before occupancy (1 point)

Criteria: Flush unit during and shortly after installing products that are known sources of contaminants (e.g., cabinets, carpet padding, paint) and for 12-hours prior to occupancy.

Clarifications:

- To flush unit either keep all windows open and run interior fans (e.g., HVAC system fans, exhaust fans and interior circulation fans) continuously, or close exterior windows and doors and run all HVAC fans, exhaust fans and interior circulation fans continuously at the highest rate. Keep all interior doors open and use additional fans to circulate air within unit.
- Replace all filters after flushing unit.

Verification:

- The EarthCraft Technical Advisor will visually confirm compliance with criteria final inspections.

High Performance Building Envelope

One of the key elements to any energy efficient building is constructing a proper building envelope. This is achieved by sealing air leaks, properly installing insulation, and using high-quality windows. The building envelope is the barrier that separates the building's conditioned space from unconditioned space or the outdoors. The building envelope consists of two components – an air barrier and a thermal barrier (insulation) that must be continuous and contiguous (touching each other). In a typical residence, the building envelope consists of the roof or ceiling, walls, windows, doors, and floor or foundation. Buildings account for about 40% of all energy use in the United States. EarthCraft encourages an energy efficient building envelope to reduce this impact.

BE 1.0 IECC adopted by jurisdiction plus applicable state amendments (requirement)

Criteria: Building must meet the International Energy Conservation Code (IECC) adopted by the project's jurisdiction plus any applicable state amendments. This is a requirement for all projects

Clarifications

- Where local code is more stringent than EarthCraft criteria, local code criteria must be met.
- In the case of a commercial construction type, the project must comply with the appropriate version of ASHRAE 90.1. This code will be in reference to commercial construction with residential use. Projects such as these will be required to follow the mid-rise/high-rise energy simulation requirements detailed in section "BE 0.2" and "BE 0.3".

Additional Resources

- For more information on state-adopted energy codes, visit www.energycodes.gov
- All state adopted codes and state amendments may be found at:
 - UpCodes: <https://up.codes/codes/general>

Verification

- Project team will provide documentation of compliance with applicable codes during the design review meeting
- The EarthCraft Technical Advisor will visually confirm compliance with criteria during mid-construction and final inspections.
- The EarthCraft Technical Advisor will confirm compliance with criteria during mid-construction and final inspection diagnostic testing.

BE 1.1 Energy efficient building envelope design (requirement)

Criteria: Complete energy modeling to determine baseline energy consumption of residential units. The energy modeling strategy selected must be based on the building height. This is a requirement for all projects.

BE 1.1.A. Low- and Mid-Rise Multifamily

- Unit-level energy modeling using RESNET compliant software shows a $\geq 20\%$ reduction in annual energy consumption compared to existing conditions.
- Building-level energy modeling demonstrates $\geq 20\%$ savings above existing baseline conditions.

BE 1.1.B. High-Rise Multifamily

- Building-level energy modeling demonstrates $\geq 20\%$ savings above existing baseline conditions.

BE 1.1.C. Adaptive Reuse Projects:

- If project is not required to meet local or state historic preservation guidelines, select energy performance pathway from options A or B above.
- Adaptive reuse projects shall use the EarthCraft Sustainable Preservation program for all low- and mid-rise structures that must comply with local or state historic preservation office requirements.

Clarifications:

- Buildings classifications are based on local/state building codes, where:
 - Low-rise residential structures are ≤ 3 stories with > 2 residential units, in-unit Heating, Ventilation, Air Conditioning (HVAC) and domestic hot water (DHW) systems and $\leq 20\%$ conditioned common space.
 - Mid-rise residential structures are 4 stories with > 2 residential units, in-unit HVAC and DHW systems and $> 10\%$ conditioned common space.
 - High-rise residential structures are ≥ 5 stories with > 2 residential units, central HVAC and/or DHW systems and $> 20\%$ conditioned common space.
- Where unit-level energy modeling is completed, sampling of worst-case unit configurations is allowed. Energy models must be confirmed in order for EarthCraft certification to be achieved.
- In instances where retail is located on bottom floors beneath a multifamily building that is > 3 stories eQuest (or equivalent) whole building simulation modeling is required.
- Adaptive reuse is defined as:
 - Any project changing transforming a building from a previously non-residential use. This may include warehouses, hotels, gyms, school buildings, or other similar types.
 - Where the adaptive reuse may be historic in nature the EarthCraft Sustainable Preservation program shall be used.

Verification:

- The EarthCraft Technical Advisor will develop worst-case unit-level energy models in accordance with RESNET modeling criteria and confirm compliance with criteria during the design review meeting.
- The EarthCraft Technical Advisor will develop an energy model meeting eQUEST design standards and confirm compliance with criteria during the design review meeting.
- The project team must present documentation demonstrating compliance with criteria to the EarthCraft Technical Advisor prior to pre-drywall inspections.
- If using RESNET approved energy modeling software, final energy models must be Confirmed.

BE 1.2 Advanced Energy Consumption Modeling**Required for Platinum certification**

Criteria: Complete energy modeling to determine baseline energy consumption of residential units. The energy modeling strategy selected must be based on the building height.

BE 1.2.A. Low- and Mid-Rise Multifamily (5 points)

- Unit-level energy modeling using RESNET compliant software shows a $\geq 30\%$ reduction in annual energy consumption compared to existing conditions.
- Building-level energy modeling demonstrates $\geq 30\%$ savings above existing baseline conditions.

BE 1.2.B. High-Rise Multifamily (5 points)

- Building-level energy modeling demonstrates $\geq 30\%$ savings above existing baseline conditions.

BE 1.2.C. Adaptive Reuse Projects:

- If the project is not required to meet local or state historic preservation guidelines, select energy performance pathway from options A or B above.
- Adaptive reuse projects shall use the EarthCraft Sustainable Preservation program for all low- and mid-rise structures that must comply with local or state historic preservation office requirements.

Clarifications:

- Buildings classifications are based on local/state building codes, where:
 - Low-rise residential structures are ≤ 3 stories with > 2 residential units, in-unit Heating, Ventilation, Air Conditioning (HVAC) and domestic hot water (DHW) systems and $\leq 20\%$ conditioned common space.
 - Mid-rise residential structures are 4 stories with > 2 residential units, in-unit HVAC and DHW systems and $> 10\%$ conditioned common space.
 - High-rise residential structures are ≥ 5 stories with > 2 residential units, central HVAC and/or DHW systems and $> 20\%$ conditioned common space.
- Where unit-level energy modeling is completed, sampling of worst-case unit configurations is allowed. Energy models must be confirmed in order for EarthCraft certification to be achieved.
- In instances where retail is located on bottom floors beneath a multifamily building that is > 3

stories eQuest (or equivalent) whole building simulation modeling is required.

- Adaptive reuse is defined as:
 - Any project changing transforming a building from a previously non-residential use. This may include warehouses, hotels, gyms, school buildings, or other similar types.
 - Where the adaptive reuse may be historic in nature the EarthCraft Sustainable Preservation program shall be used.

Verification:

- The EarthCraft Technical Advisor will develop worst-case unit-level energy models in accordance with RESNET modeling criteria and confirm compliance with criteria during the design review meeting.
- The EarthCraft Technical Advisor will develop an energy model meeting eQUEST design standards and confirm compliance with criteria during the design review meeting.
- The project team must present documentation demonstrating compliance with criteria to the EarthCraft Technical Advisor prior to pre-drywall inspections.
- If using RESNET approved energy modeling software, final energy models must be Confirmed.

BE 1.3 $\geq 40\%$ Reduction in Energy Consumption (10 points)

Criteria: Unit-level energy modeling using RESNET compliant software or building level energy modeling demonstrates $\geq 40\%$ reduction in annual energy consumption compared to existing conditions.

Clarifications:

- Buildings classifications are based on local/state building codes, where:
 - Low-rise residential structures are ≤ 3 stories with > 2 residential units, in-unit Heating, Ventilation, Air Conditioning (HVAC) and domestic hot water (DHW) systems and $\leq 20\%$ conditioned common space.
 - Mid-rise residential structures are 4 stories with > 2 residential units, in-unit HVAC and DHW systems and $> 10\%$ conditioned common space.
 - High-rise residential structures are ≥ 5 stories with > 2 residential units, central HVAC and/or DHW systems and $> 20\%$ conditioned common space.
- Where unit-level energy modeling is completed, sampling of worst-case unit configurations is allowed. Energy models must be confirmed in order for EarthCraft certification to be achieved.
- In instances where retail is located on bottom floors beneath a multifamily building that is > 3 stories eQuest (or equivalent) whole building simulation modeling is required.
- Adaptive reuse is defined as:
 - Any project changing transforming a building from a previously non-residential use. This may include warehouses, hotels, gyms, school buildings, or other similar types.
 - Where the adaptive reuse may be historic in nature the EarthCraft Sustainable Preservation program shall be used.

Verification:

- The EarthCraft Technical Advisor will develop worst-case unit-level energy models in accordance with RESNET modeling criteria and confirm compliance with criteria during the design review meeting.
- The EarthCraft Technical Advisor will develop an energy model meeting eQUEST design standards and confirm compliance with criteria during the design review meeting.
- The project team must present documentation demonstrating compliance with criteria to the EarthCraft Technical Advisor prior to pre-drywall inspections.
- If using RESNET approved energy modeling software, final energy models must be Confirmed.

BE 2: Air Sealing Measures

The High-Performance Building Envelope (BE) section BE 2: Air Sealing Measures covers specific prescriptive air sealing requirements for all projects, regardless of construction type and building height. Air sealing requirements apply to all construction types, building heights and framing materials.

BE 2.0 Seal bottom plates to subfloor or foundation for entire unit envelope (requirement)

Criteria: Seal bottom plates to subfloor or foundation for entire unit envelope in all areas where subfloor is exposed during construction. Air sealing shall occur where:

- Between sill plate and subfloor, using caulk, foam, or equivalent material
- Install a foam gasket beneath sill plates that are sitting on concrete or masonry

This is a requirement for all projects.

Additional Information:

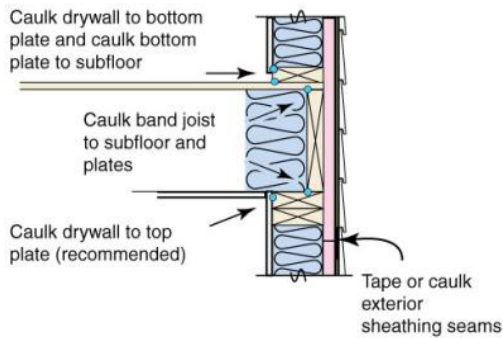

Air seal bottom plate to subfloor between floors/units, and ensure framing at band areas are air sealed

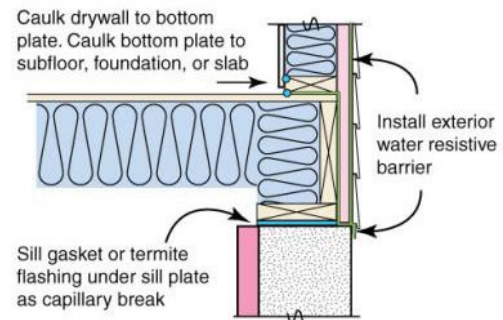

Use foam/gasketed sill seal where bottom plates sit on poured concrete or concrete blocks. Air seal bottom plate to subfloor between floors/units, and ensure framing at band areas are air sealed

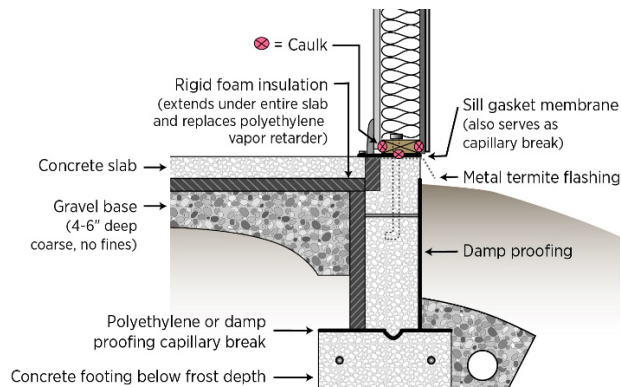

Use foam/gasketed sill seal where bottom plates sit on poured concrete or concrete blocks.

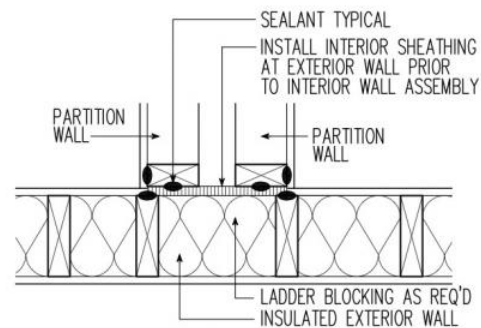

Air seal bottom plates at common walls between residential units. This may also be accomplished through the use of poured gypcrete.

Images Source: Building America Solution Center: <https://basc.pnnl.gov/>

Clarifications:

- Appropriate sealants in all areas include caulk and sprayed foam materials approved for air sealing and/or fire sealing.
- Poured gypcrete may be used to seal bottom plates to subfloors

Verification:

- Project team will provide documentation of compliance during the design review meeting
- The EarthCraft Technical Advisor will visually confirm compliance with criteria during mid-construction and final inspections.

BE 2.1 Block and seal joist cavities (requirement)

Criteria: Block and air seal joist cavities separating conditioned space in residential units from unconditioned and/or common spaces. This is a requirement for all projects.

BE 2.1.1. Above attached garage walls

- **Criteria:** Using rigid blocking and appropriate sealant, block and seal all joist cavities above the attached garage wall.

BE 2.1.2. Above supporting wall at cantilevered floors

- **Criteria:** Using rigid blocking and appropriate sealant, block and seal all cantilevered floor joist cavities above the top plate of the supporting wall.
 - Seal exterior sheathing on bottom of cantilevered floor.

BE 2.1.3. Under attic knee walls

- **Criteria:** Using rigid blocking and appropriate sealant, block and seal all joist cavities below knee wall.

BE 2.1.4. Between units and corridors

- **Criteria:** Using rigid blocking and appropriate sealant, block and seal all joist in framing areas between residential units and corridors. This applies to conditioned and unconditioned corridors.

Additional Information:

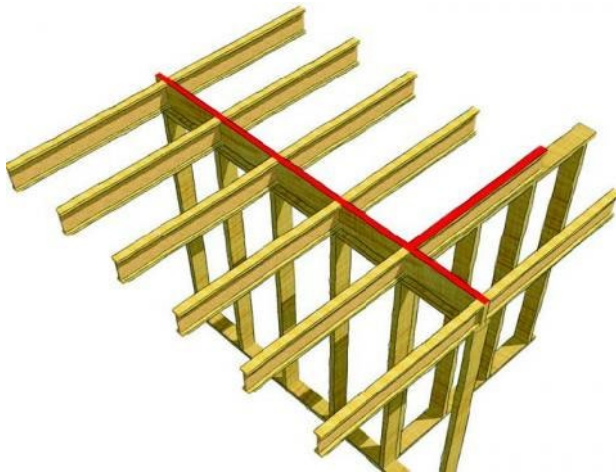

Block joist cavities between attached garages and living spaces in wood or metal framed buildings. Blocking materials must be used for gaps larger than 1 inch, with air sealing materials to be used all gaps and seams larger than 1/8 inch.

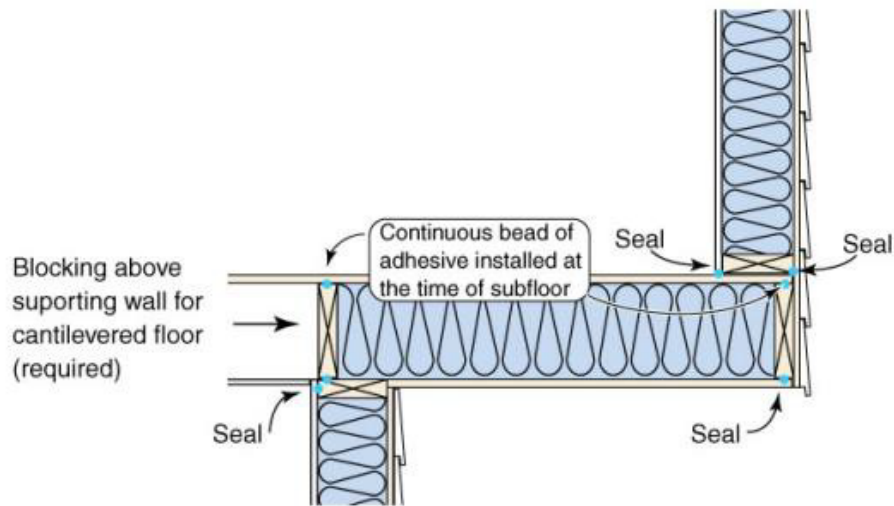

Cantilevers with conditioned space above them shall be air sealed at the base of the exterior wall that sits on top of the cantilever and at the interior side of the exterior wall that serves as the base of the cantilever. The cantilever cavity shall be filled completely with insulation to ensure that the floor of the conditioned space remains in contact with the insulating material.

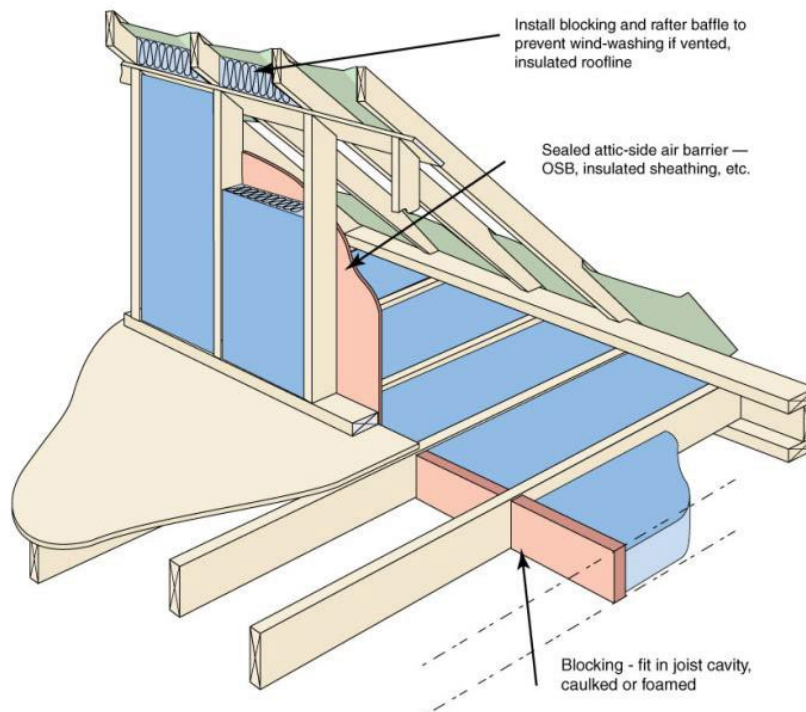

Attic knee walls (at conditioned units and conditioned corridors) must be air sealed at floor joists and at ceilings without roof vent chutes. The wall cavities must be filled with insulation and the attic-side of the wall covered with an air-impermeable barrier.



Band areas separating conditioned space from unconditioned space and/or corridors/common spaces shall be blocked and air sealed. Blocking shall be installed prior to rough-in of mechanical, electrical, or plumbing components. All penetrations in blocking shall be air sealed. If the band area is exposed to unconditioned space on one side, it shall be insulated in addition to being air sealed.

Images Source (attached garage, knee wall and cantilever): Building America Solution Center: <https://basc.pnnl.gov/>
Image Source band area: Southface Institute

Clarifications:

- Attic knee walls, defined as a vertical or near-vertical wall separating conditioned space from unconditioned attic space which also include skylight shaft walls or walls adjacent to porch roofs.
- Walls separating garages and conditioned living space shall be tested to ensure there is no air leakage pathway that may introduce garage pollutants to living space occupants.

Verification:

- The EarthCraft Technical Advisor will visually confirm compliance with criteria during mid-construction and final site inspections.

BE 2.2 Block stud cavities at change in ceiling height (requirement)

Criteria: Block stud cavities at locations of varying ceiling height, including common walls between adjacent rooms and dropped ceilings in hallways. This is a requirement for all projects.

Additional Information:

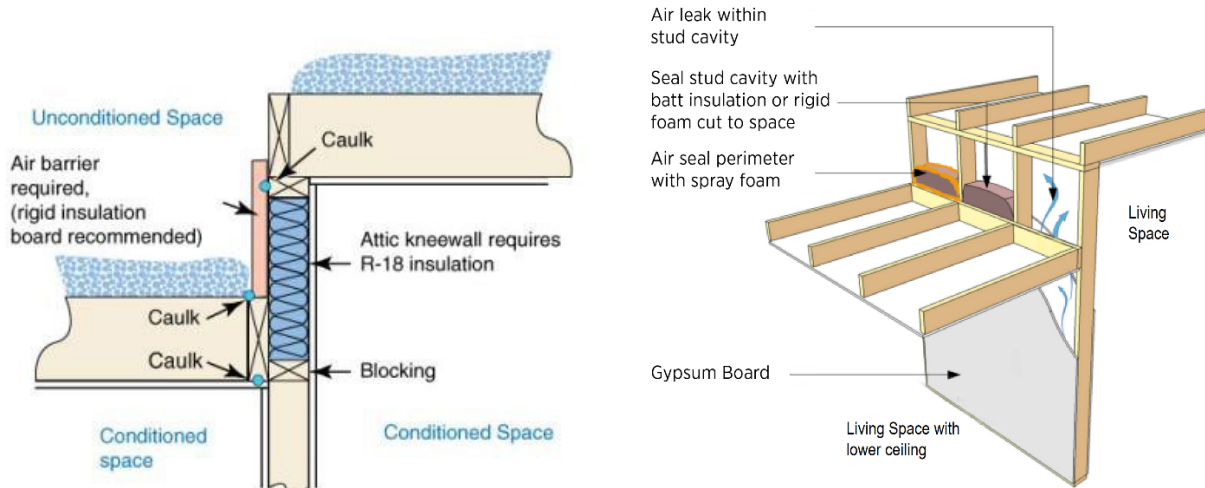

Changes in ceiling height for any reason should be treated as knee walls where blocking is provided at both sides of the cavity and the total insulation level is greater than or equal to the minimum R-value required for knee walls.

Image Source (right): <https://basel.pnnl.gov/resource-guides/air-seal-top-plates-or-blocking-missing-top-walls-adjointing-unconditioned-spaces#edit-group-description>

Clarifications:

- Changes in ceiling height ≥ 18 inches are considered attic knee walls and shall meet the criteria as listed in BE 2.2.3
- Changes in ceiling height < 18 inches shall be blocked and air sealed, as illustrated in the diagram above, and insulation at the attic side shall be installed to meet R-value requirements for the attic.

Verification:

- The EarthCraft Technical Advisor will visually confirm compliance with criteria during mid-construction and final site inspections.

BE 2.3 Install blocking and baffles in insulated and vented vaulted ceilings (requirement)

Criteria: Install blocking in rafter cavities above top plate of exterior wall if air-permeable insulation (e.g., fiberglass batts or blown-in insulation) is used and the roofing assembly must be ventilated. Blocking must be in contact with rafter baffle to allow proper roof deck ventilation and prevent wind-washing of insulation. This is a requirement for all projects.

Additional Information:

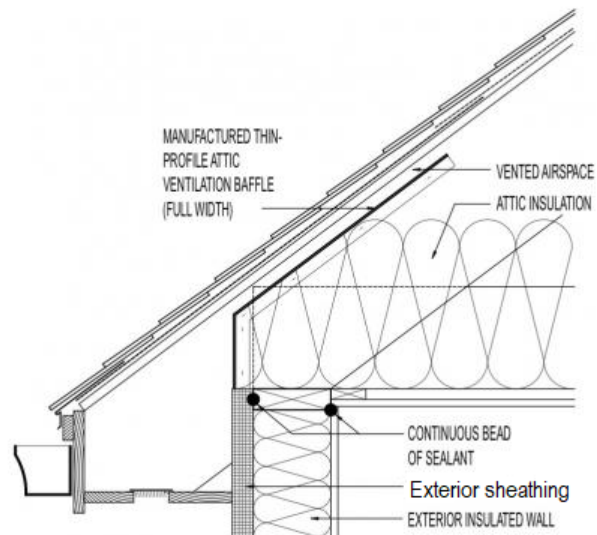

Install wind baffles between roof rafters where soffit vents are located for attic ventilation. Baffles should be installed to allow maximum insulation depth at the perimeter of the exterior wall while allowing air ventilation along the underside of the roof assembly.

Image Source: <https://basc.pnnl.gov/cad-files/thin-profile-attic-eave-baffle-and-vent>

Verification:

- The EarthCraft Technical Advisor will visually confirm compliance with criteria during mid-construction and final site inspections.

BE 2.4 Seal gaps larger than ¼ inch at all residence exterior walls, ceilings, and floors (requirement)

Criteria: Air seal penetrations in framing, exterior walls, and band areas. Locations include penetrations created for the installation of mechanical, electrical, and plumbing components, gaps between framing members, and gaps within wall assembly components. This is a requirement for all projects.

BE 2.4.1. Top and bottom plate

- Air seal all holes in the top and bottom plates for plumbing, electrical wiring, and other purposes in walls separating conditioned and unconditioned (including exterior) areas. Appropriate air sealing materials include spray applied foam, polyurethane caulk, fire rated caulk or an equivalent material.

BE 2.4.2. Band and rim joists

- Air seal all penetrations through the band and rim joist (between conditioned and exterior spaces, corridors and/or common spaces) including but not limited to: holes drilled for HVAC lines, plumbing lines, bathroom fans, exhaust ductwork, electrical lines. Appropriate air sealing materials include spray applied foam, polyurethane caulk, fire rated caulk or an equivalent material.

BE 2.4.3. Subfloor

- Air seal all penetrations (e.g., HVAC, plumbing and electrical) through floor systems over adjacent residences, common areas, and unconditioned areas. Appropriate air sealing materials include spray applied foam, polyurethane caulk, fire rated caulk or an equivalent material.

BE 2.4.4. Sheathing

- Air seal penetrations in exterior wall sheathing including condensation lines, electrical outlets, water spigots, utility boxes and locations with broken or missing sheathing. Appropriate air sealing materials include spray applied foam, polyurethane caulk, fire rated caulk or an equivalent material.
- Sheathing includes the material that comprises the exterior-most plane of wall that is behind the drainage plane and exterior cladding. This includes, but is not limited to, OSB, dense glass, structurally insulated panels (SIP), foam board and/or sheathing with a drainage plane integrated into it (spray applied onsite or manufactured).
- Tape that is used as part of the drainage plane is not considered an air sealing material for gaps larger than ¼ inch.

BE 2.4.5. Walls and ceilings in attached garages

- Air seal penetrations such as light fixtures, switches, electric boxes and plumbing pipe penetrations through wall and ceiling drywall in attached garage. Appropriate air sealing materials include spray applied foam, polyurethane caulk, fire rated caulk or an equivalent material.
- Penetrations shall be air sealed at blocking materials during mid-construction per the criteria identified in BE 2.1.1.
- If, during final inspections, air leakage is identified additional air sealing shall be completed at the drywall penetrations.

BE 2.4.6. Drywall penetrations in insulated ceilings and walls

- Air seal penetrations (e.g. rough openings for can lights, ceiling fans and low voltage fixture penetrations) through all ceilings separating conditioned space from unconditioned space, adjacent residential units and/or common areas. Air seal penetrations in insulated walls (e.g. light switches and electrical boxes) in exterior walls, knee walls and adiabatic walls between residential units.

Additional Information:

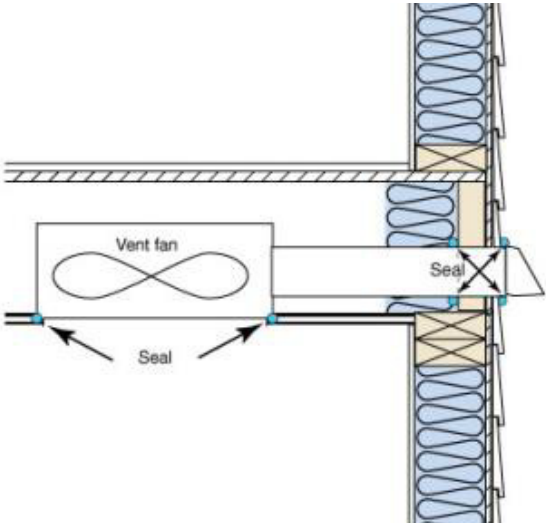

Air seal penetrations in exterior wall where bath fan ductwork (pictured), kitchen range hood ductwork, and/or dryer exhaust duct work terminates through the wall. Additionally, air seal at the drywall where the fan housing (bath fan, pictured) or dryer ductwork is installed at the interior wall.

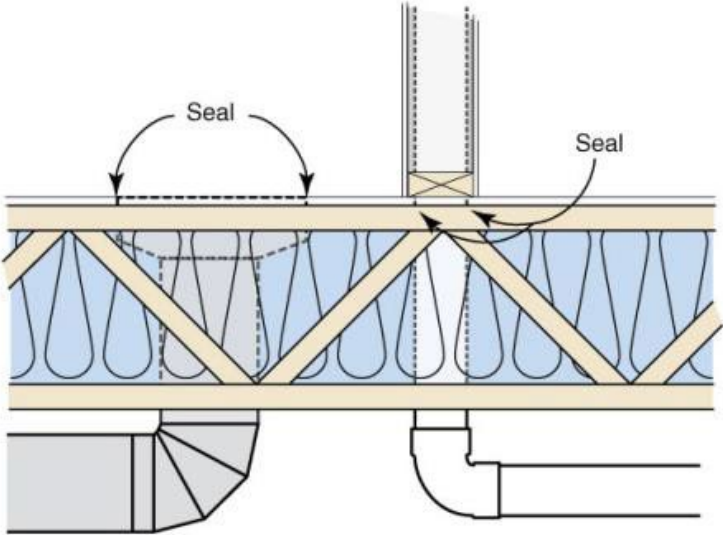

Air seal floor penetrations such as HVAC boots (pictured) and plumbing pipes through bottom plates (pictured). In wet areas such as bathrooms poured gypcrete is an acceptable air sealing material.

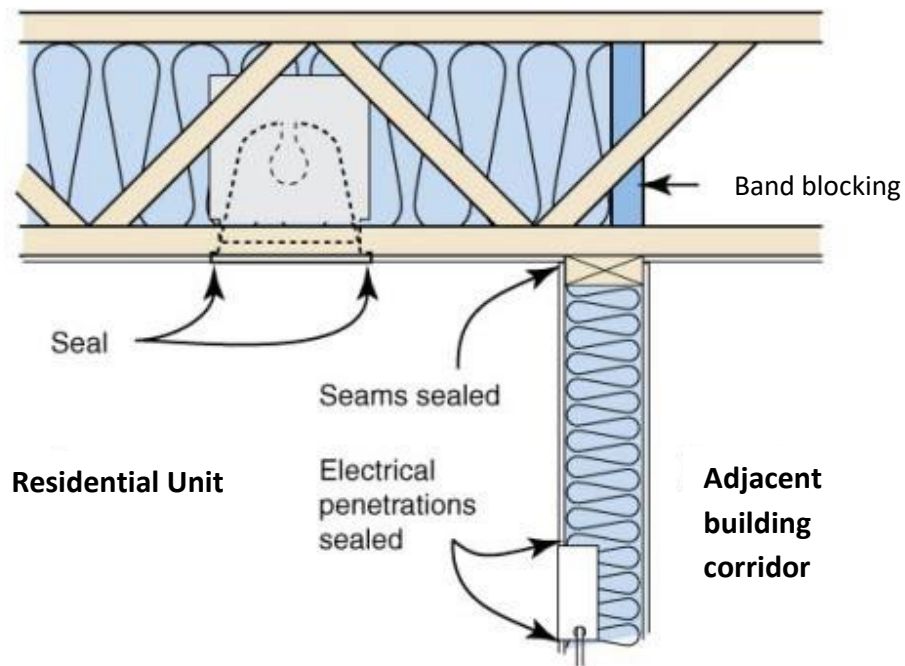

Air seal drywall penetrations for electrical, mechanical, and plumbing fixtures

Clarifications:

- Seal penetrations for gas system flues and other heat-producing items with noncombustible sheet materials and high temperature sealant.

Verification:

- The EarthCraft Technical Advisor will visually confirm compliance with criteria during mid-construction and final site inspections.

BE 2.5 Verify air sealing of penetrations at specific locations (requirement)

Criteria: Air seal penetrations at the following locations, regardless of the size hole. Air sealing materials selected shall be compatible with the materials they come into contact with and capable of handling naturally occurring expansion/contraction. This is a requirement for all projects.

BE 2.5.1. Shower and tub drains

- Using an appropriate backing for holes larger than ½ inch and sealant material, block and seal subfloor penetrations for shower and tub drain. Plumbing penetrations in slab floors must be sealed with appropriate sealant.

BE 2.5.2. HVAC supply and return boots sealed to subfloor or drywall (floors, walls, and ceilings)

- Using appropriate sealant, seal all HVAC supply and return boots to subfloor and/or drywall.
- Air sealing shall be completed for all ductwork located within and outside of conditioned space.

BE 2.5.3. Window and door rough openings

- Using non-expanding or low-expanding spray foam sealant or closed-cell foam backer rod with appropriate sealant, seal the space between the framing for window and door rough openings and the installed units.
- Seal thresholds for exterior doors to the subfloor or slab.

BE 2.5.4. All drywall penetrations in common walls between adjacent residences

- For all common walls between two dwelling units (e.g., duplexes, townhomes and multifamily), seal all penetrations through the top and bottom plate, and all drywall penetrations where permissible by fire code.

BE 2.5.5. Exhaust fans to drywall

- Using appropriate sealant, seal all bathroom and kitchen exhaust fan housing units to drywall.

BE 2.5.6. Attic pull-down stairs, scuttle holes and knee wall doors

- Using non or low-expanding spray foam sealant or closed-cell foam backer rod with appropriate sealant, seal the space between the framing and attic pull-down stairs, scuttle holes or knee wall doors.

BE 2.5.7. Chases

- Using sheet material and appropriate sealant, seal and insulate framed spaces that connect conditioned areas to unconditioned areas above and below the chase (including attics, unconditioned basements, or other foundation spaces).
- These areas include chases for plumbing, duct work, chimneys, and HVAC flues.

Additional Information:

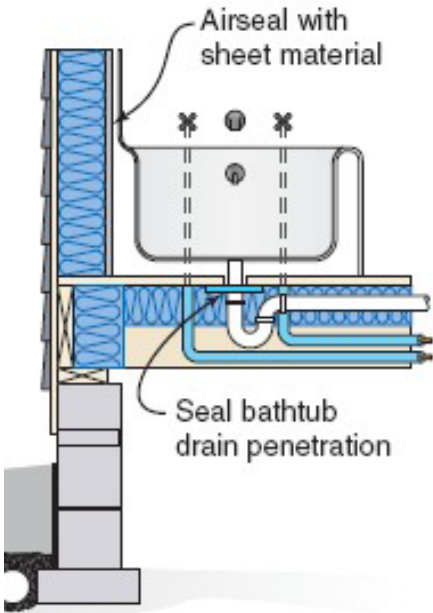

Block and air seal all plumbing penetrations for water lines and sewage piping. Holes larger than 1/2 inch shall be blocked prior to the use of air sealing materials. Poured gypcrete in floors is an acceptable air sealing material in those locations.

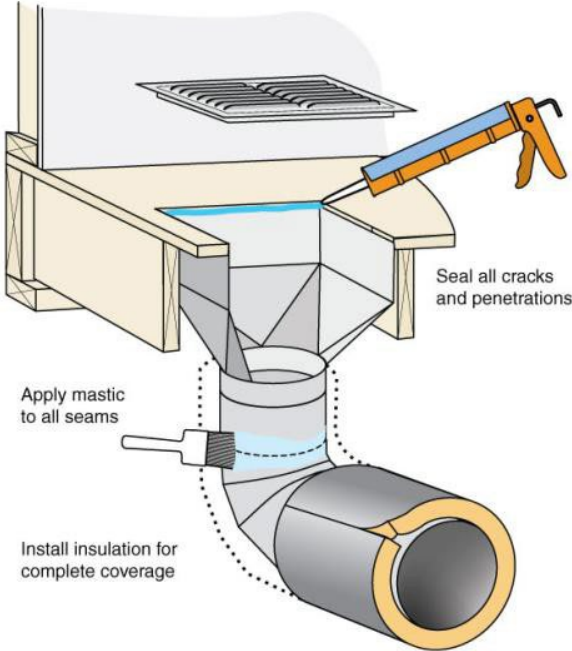

Use an appropriate material to air seal HVAC supply and return boots to subfloors at rough-in and/or drywall at final. Air sealing at these locations is required for all ductwork located in conditioned and unconditioned spaces.

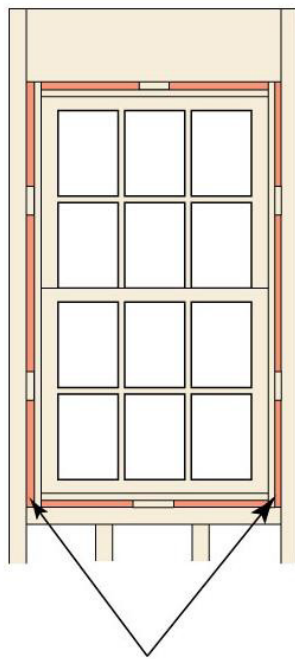

Use backer rod or low expanding spray foam (appropriate for windows) to fill gaps between window/door and rough opening

Air seal the rough opening on all sides around windows and exterior doors. Low-expansion foam may be used, or backer rod with caulk.

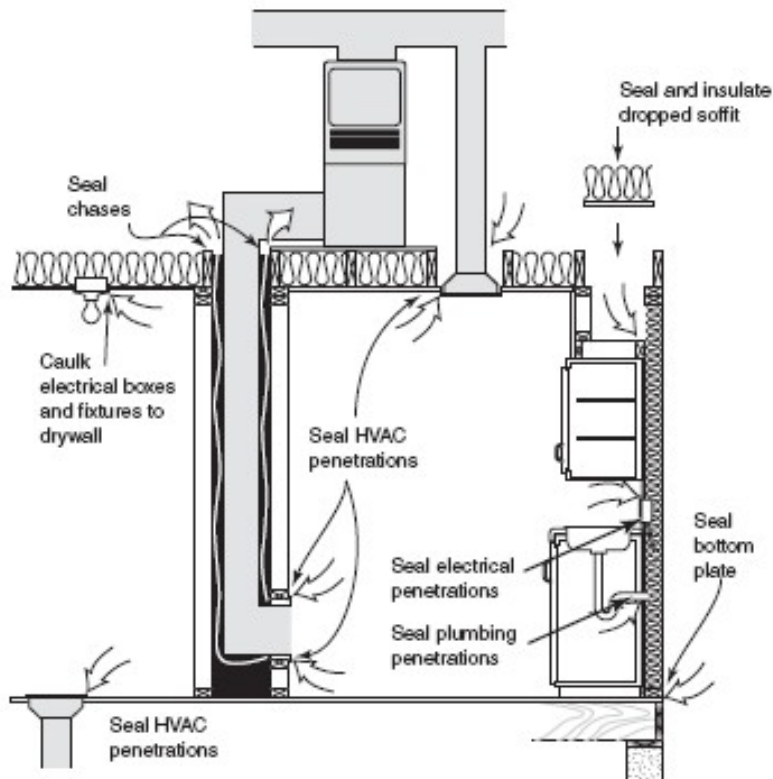

Air seal all drywall penetrations in residence exterior walls and ceilings, such as bath fan housing, electrical outlets, ceiling lights, and ceiling fans.

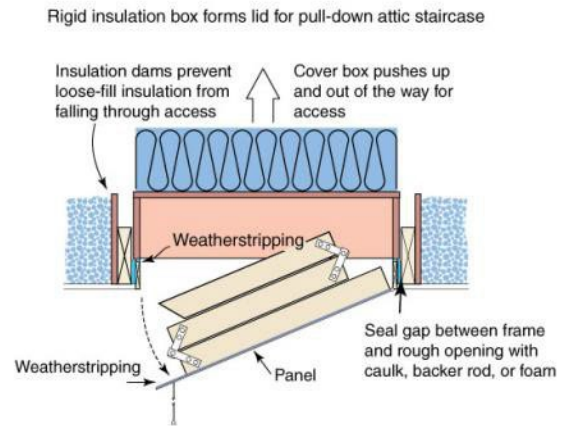
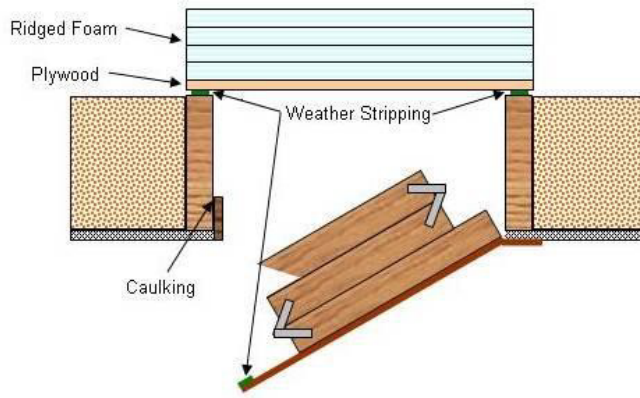

Attic access stairs or scuttle holes located in conditioned space shall be air sealed and insulated to the same R-value as the surrounding attic. If attic access is located in a knee wall, install an exterior door that is weather stripped and insulated on the attic side.

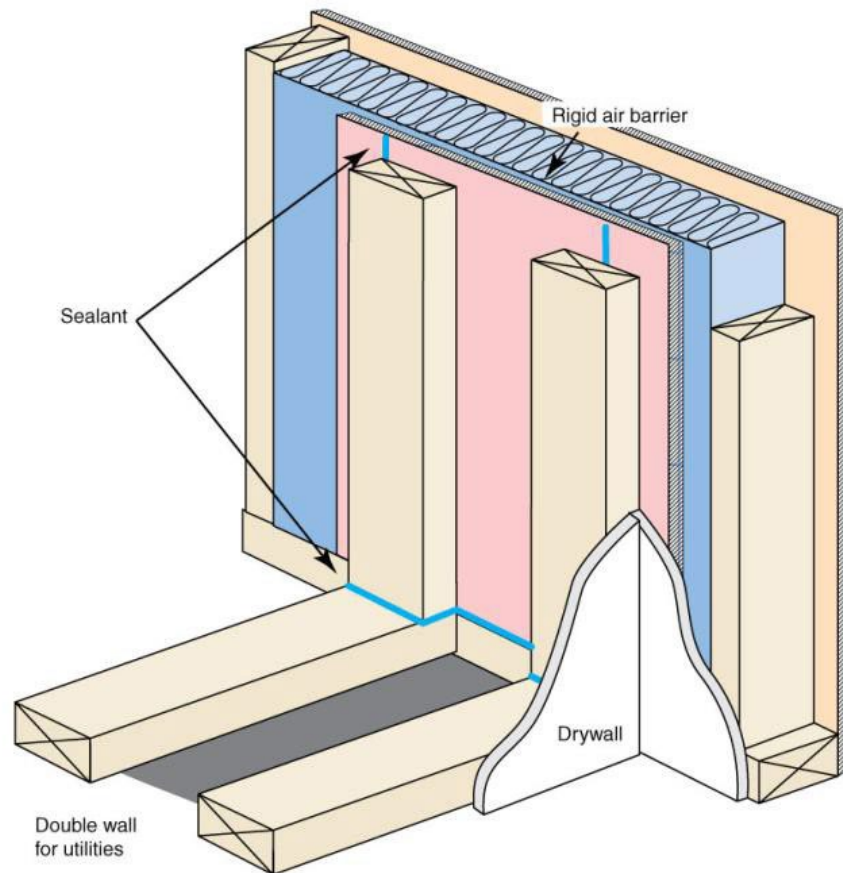

Chases shall be capped at the top and sealed with an appropriate material.

Clarifications:

- Cellulose, fiberglass, or rockwool-batt insulation is not acceptable as a sealant.
- For chases with high temperature heat sources, use noncombustible sheet materials such as sheet metal and high temperature caulk to seal chase.

Verification:

- The EarthCraft Technical Advisor will visually confirm compliance with criteria during mid-construction and final site inspections.

BE 2.6 Install rigid air barriers (requirement)

Criteria: Install rigid air barriers in exterior areas that are not normally covered with drywall at the interior and/or sheathing at the exterior. This is a requirement for all projects.

BE 2.6.1. Behind tubs and showers on insulated walls

- Install a rigid interior air barrier behind tubs and showers on insulated walls before installing tub and shower assemblies. The air barrier cannot be a paper-faced material.

BE 2.6.2. At attic knee wall on attic-side (including skylight shafts)

- Install an attic-side rigid air barrier to all knee walls, including skylight shafts.
- Using appropriate sealant, seal seams of air barrier. Block and seal top and bottom of knee wall/skylight shaft stud cavity to encapsulate insulation.
- Attic knee wall shall meet the total insulation R-value required in BE 4.4
- Air sealing shall comply with BE 2.4 and BE 2.5

BE 2.6.3. At chases in contact with the building envelope (including fireplace chases)

- All chases in contact with residence building envelope or walls adjacent to other residences must have an air barrier applied to the interior of the chase where it meets the building envelope. All chase walls must be sealed using appropriate sealant (i.e., compliant with applicable fire code and manufacturer specifications).

BE 2.6.4. Along staircases on insulated walls

- Install rigid air barrier to the interior of all staircase walls adjoining unconditioned spaces (e.g., exterior walls, garages, or unconditioned attics). Using appropriate sealant, seal seams of air barrier and penetrations through air barrier. Air barrier should include areas under enclosed landings and bottom stairs.

BE 2.6.5. Along porch roofs

- Seal and insulate all porch roofs separating unconditioned and conditioned space if blocking, air sealing and insulation are not installed at the vertical connection between the conditioned interior of the unit and the porch roof area.

Additional Information:

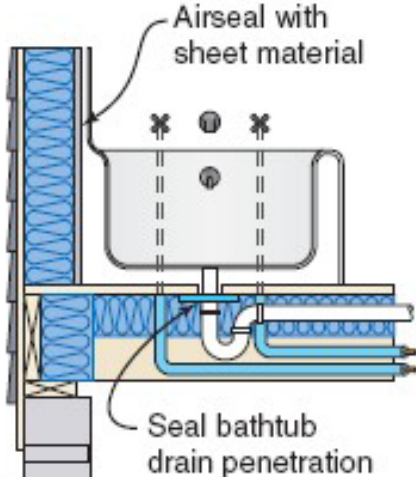

Install a solid air barrier to cover exterior wall insulation installed behind bath tubs and/or showers installed on exterior walls.

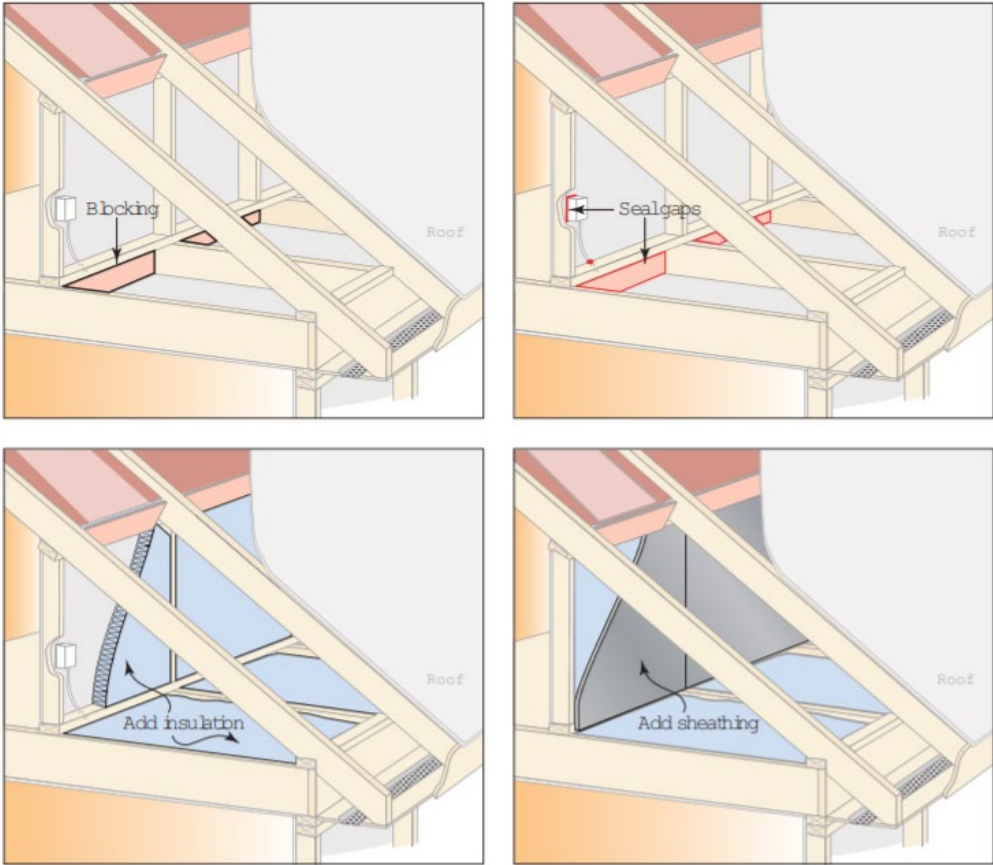

Attic knee walls shall be air sealed along the interior wall to meet BE 2.4 and BE 2.5. Insulation levels shall meet BE 4.4

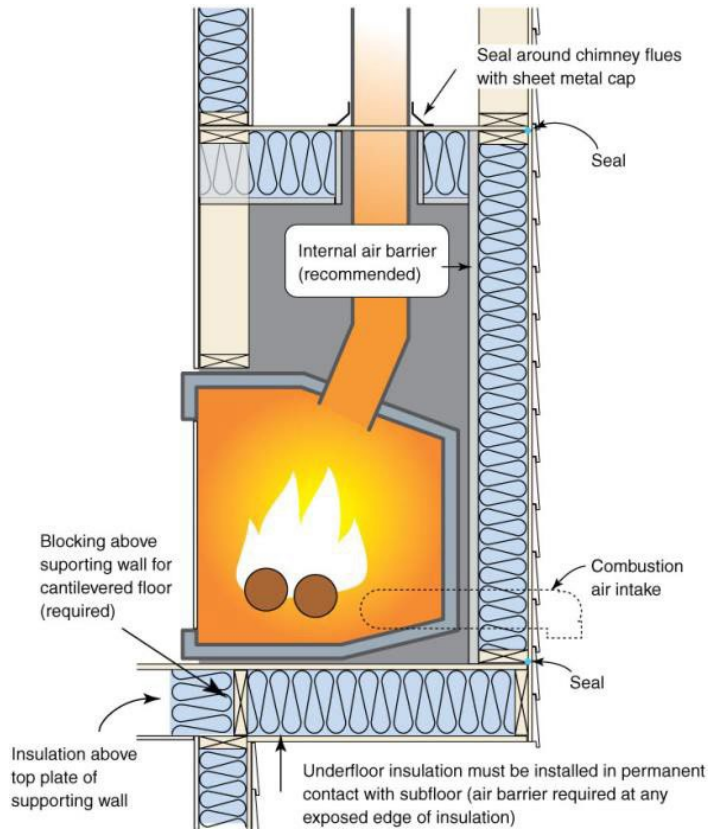

Chases for fireplaces installed in residences and common areas shall be blocked and air sealed with materials compliant for use in contact with heat sources. All fireplaces shall meet the criteria listed in IAQ 1.0 and IAQ 1.3

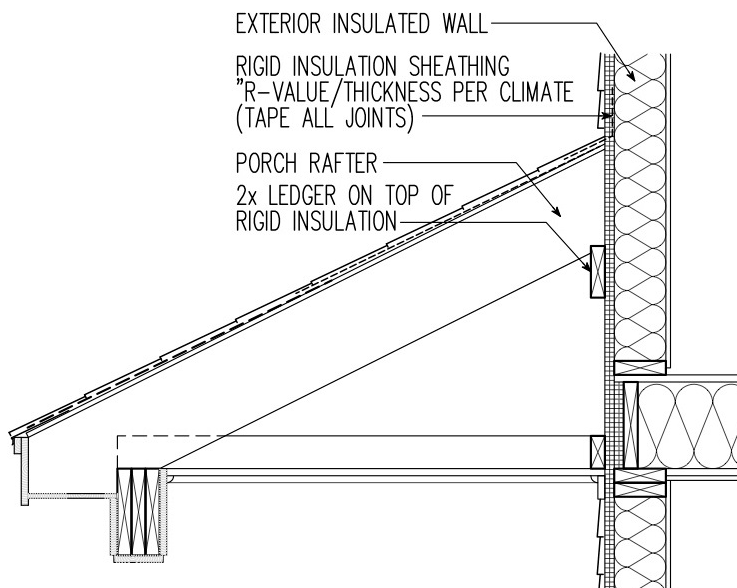

Sheath the exterior side of walls that are exposed to porch roofs.

Clarifications:

- If cavity will be inaccessible for insulation installation after sheathing is applied, install insulation prior to enclosing the cavity.
- All fireplace chase walls must be sealed using appropriate sealant (i.e., compliant with applicable fire code and manufacturer specifications).
- For units in Climate Zones 2-3 with Grade II insulation installation or worse on fireplace chase walls, and for all units in Climate Zone 4, an internal air barrier must be installed on fireplace chase walls in addition to the exterior air barrier on fireplace chase walls.
- Changes in ceiling height 18" or greater are considered attic knee walls.

Verification:

- The EarthCraft Technical Advisor will visually confirm compliance with criteria during mid-construction and final site inspections.

BE 2.7 Install weather-stripping (requirement)

Criteria: Weather stripping shall be installed permanently at all exterior doors and attic access doors located within conditioned space. This is a requirement for all projects.

BE 1.7.1. At all exterior doors

Install weather-stripping to all exterior doors that connect conditioned space to unconditioned spaces like the garage or outdoors.

BE 2.7.2. At attic knee wall doors, scuttle holes and pull-down stairs

Weather-strip all knee wall doors, scuttle holes and pull-down stairs that connect conditioned space to unconditioned attic areas. Knee wall doors must latch to provide tight closure. Install weather stripping prior to setting hinges on pull-down stairs to ensure tight closure of assembly between conditioned space and attic.

Additional Information:

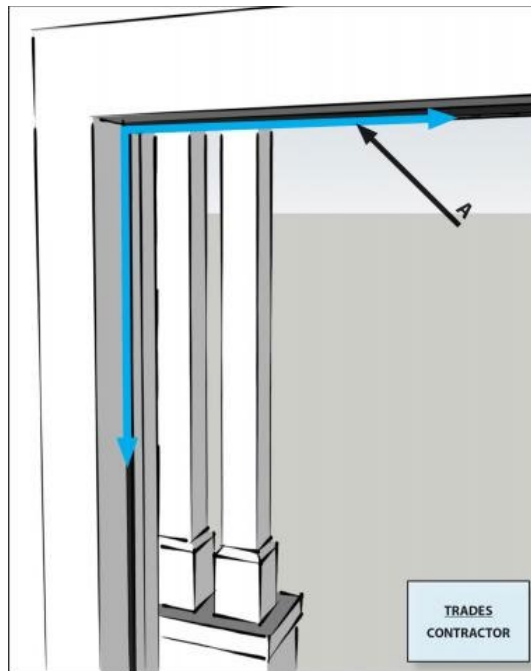

Ensure all residence exterior doors, including doors to conditioned corridors, have weather stripping on the top and both sides, and a door sweep at the bottom.

Image credit: DOE Building America Solution Center: <https://basc.pnnl.gov/images/air-seal-exterior-doors-minimize-air-leakage>

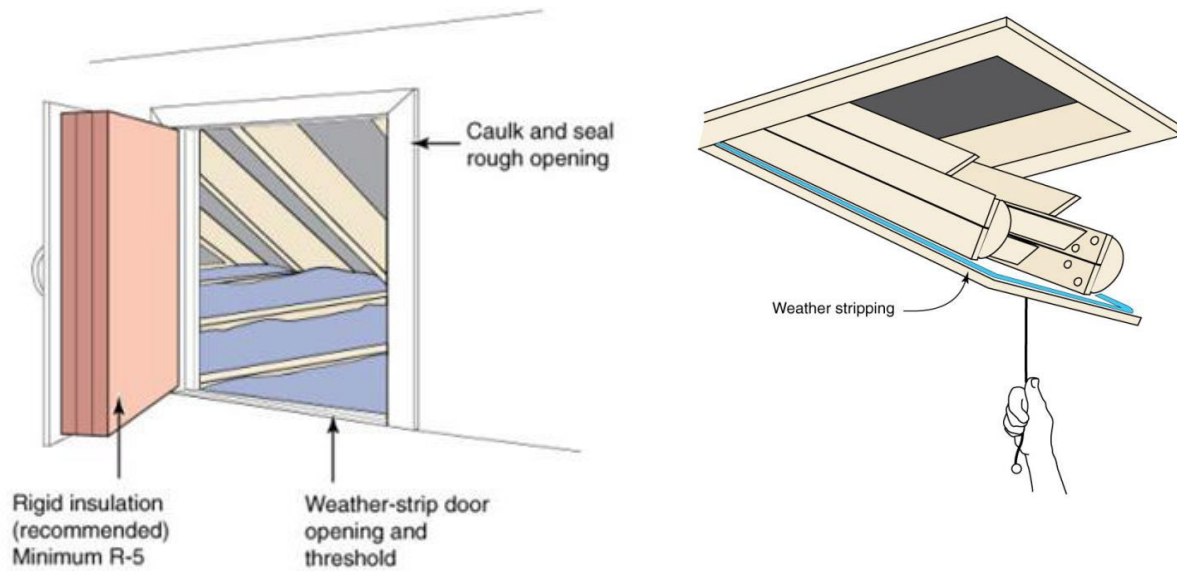

Attic access doors located within conditioned space and scuttle holes shall be installed with weather stripping at the door and air sealed and insulated to meet BE 2.1, BE 2.5 and BE 4.4.

Verification:

- The EarthCraft Technical Advisor will visually confirm compliance with criteria during mid-construction and final site inspections.

BE 2.8 All new recessed can lights must be air-tight and gasketed; IC-rated in insulated ceilings (requirement)

Criteria: Recessed light fixtures in ceilings must be air-tight and fully-gasketed. Recessed light fixtures installed in insulated ceilings must be Insulation Contact (IC) rated. All recessed lights must be sealed to the drywall. This is a requirement for all projects.

Additional Information:

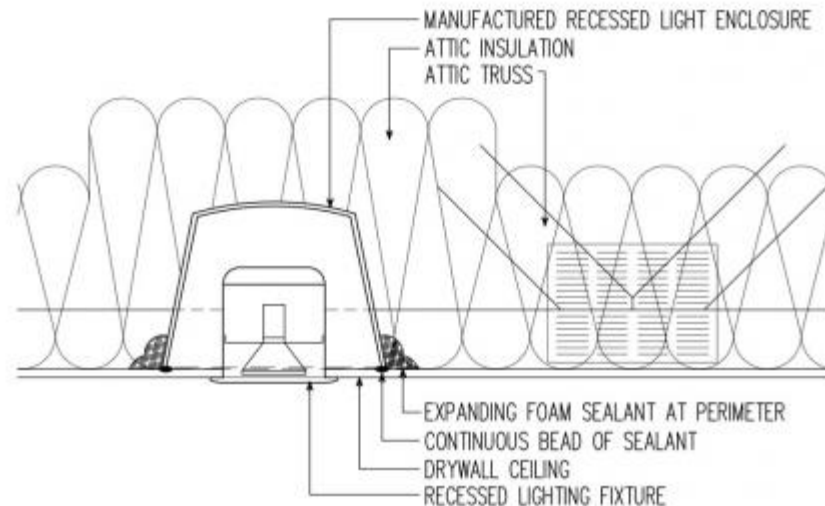

Recessed lights shall be gasketed, air-tight fixtures that are air sealed to the finished drywall ceiling. Fixtures installed in insulated ceilings shall be insulation contact (IC) rated.

Image Credit: DOE Building America Solution Center, <https://bas.c.pnnl.gov/cad-files/air-sealing-recessed-lighting-attic-pre-made>

Clarifications:

- IC rated can lights installed in insulated ceilings shall be insulated to meet local requirements.

Verification:

- The EarthCraft Technical Advisor will visually confirm compliance with criteria during mid-construction and final site inspections.

BE 2.9 Gypcrete on all framed floors separating unit envelopes (4 points)

Required for Platinum certification

Criteria: Apply gypcrete in spaces between tenant separation walls or any dead cavities existing between units or between units and common areas. This is a requirement for all projects.

Additional Information:



Pour gypcrete in cavity spaces between residential units, spaces separating residential units and common spaces, and in building cavities that will be inaccessible after drywall has been installed. Inaccessible areas include spaces under bathtubs/shower inserts.

Clarifications:

- Apply an additional application of gypcrete in areas otherwise blocked by drywall. Such areas will include space beneath tubs and chases.

Verification:

- The EarthCraft Technical Advisor will visually confirm compliance with criteria during mid-construction site inspections.

BE 2.10 Seal top plate to drywall at the attic level (2 points)

Required for Platinum certification

Criteria: Seal top plate to drywall at all interfaces with appropriate sealant (gaskets, foam, caulk, etc.) between unconditioned spaces and wall. Sealant may be applied from the attic side to joints between drywall and top plate. This is a requirement for projects seeking Gold and Platinum level certification.

Additional Information:

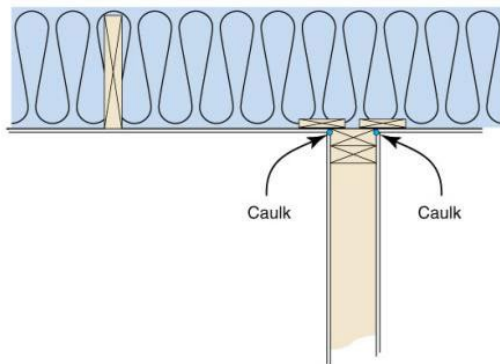

Air seal top plates to drywall for all units by applying air sealing materials at the drywall-to-framing connections in the attic or by installing a gasket to the underside of the top plates prior to hanging the drywall. If using a gasket, ensure that the material is folded at a 90° angle and secured to the side of the top plate and underside of any deadwood/metal channel.

Clarifications:

- Seal drywall to top plate for walls separating the conditioned space from garage space.
- Construction adhesive is not permitted as sealant.

Verification:

- The EarthCraft Technical Advisor will visually confirm compliance with criteria during final diagnostic testing and site inspections.

BE 2.11 Seal all interior drywall penetrations (4 points)

Criteria: Using appropriate sealant, seal all penetrations in interior/uninsulated walls, including wall switches, electrical outlets, and plumbing penetrations, to drywall. This is a requirement for projects seeking Platinum certification.

Verification:

- The EarthCraft Technical Advisor will visually confirm compliance with criteria during final diagnostic testing and site inspections.

BE 2.12 Two-pour application of gypcrete in framed areas blocked by drywall (1 point)

Criteria: Apply two layers of gypcrete between all residence common areas and other spaces separating residences from adjacent units and/or common areas, such as under bathtub/shower systems, at the base of plumbing chases, etc.



Apply two layers of gypcrete in cavity spaces between residential units, spaces separating residential units and common spaces, and in building cavities that will be inaccessible after drywall has been installed. Inaccessible areas include spaces under bathtubs/shower inserts.

Clarifications:

- A two-part gypcrete pour should be completed in two phases, with time between pours for the first layer to settle and allow gaps/under covered areas to receive an appropriate sealing during the second pour.

Verification:

- The EarthCraft Technical Advisor will visually confirm compliance with criteria during mid-construction site inspections.

BE 2.13 Replace existing non-ICAT rated can lights with ICAT rated ones (2 points)

Criteria: Recessed light fixtures in ceilings must be air-tight and fully-gasketed. Recessed light fixtures installed in insulated ceilings must be Insulation Contact (ICAT) rated. All recessed lights must be sealed to the drywall. This is a requirement for all projects.

Additional Information:

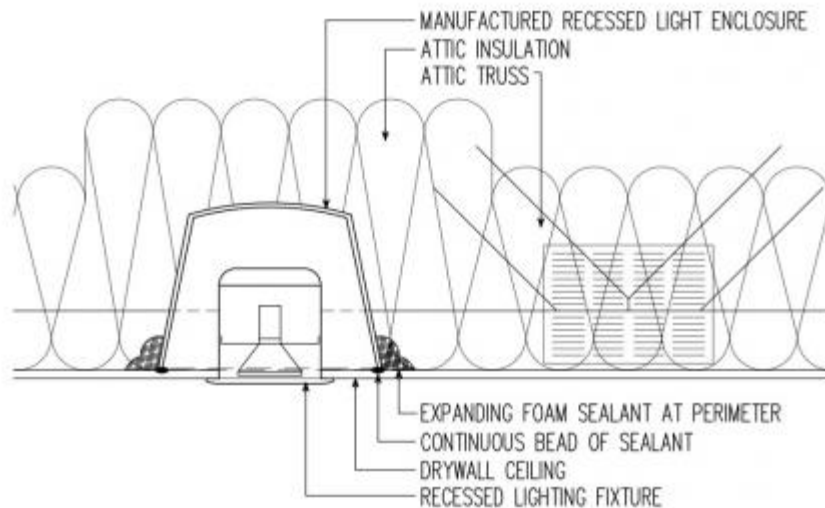

Recessed lights shall be gasketed, air-tight fixtures that are air sealed to the finished drywall ceiling. Fixtures installed in insulated ceilings shall be insulation contact (IC) rated.

Image Credit: DOE Building America Solution Center, <https://bascc.pnnl.gov/cad-files/air-sealing-recessed-lighting-attic-pre-made>

Clarifications:

- IC rated can lights installed in insulated ceilings shall be insulated to meet local requirements.

Verification:

- The EarthCraft Technical Advisor will visually confirm compliance with criteria during mid-construction and final site inspections.

BE 2.14 No recessed lighting installed in insulated ceilings (1 point)

Criteria: Do not install recessed lighting in insulated ceilings within the project.

Verification:

- The EarthCraft Technical Advisor will visually confirm compliance with criteria during final diagnostic testing and site inspections.

BE 3: Blower Door Test

Blower door testing is required for all EarthCraft projects to verify the air tightness of building envelopes and identify where additional air sealing may be necessary. The EarthCraft program has minimum air leakage limits for all projects and awards points to projects that achieve different thresholds of air tightness. Two leakage measurements are referenced by EarthCraft: Air Changes per Hour (ACH₅₀) and Envelope Leakage Ratio (ELR₅₀) when the field leakage measurement is recorded at a Cubic Feet per Minute (CFM₅₀) pressure difference of 50 Pascals between the conditioned area and the outdoors. Below are the definitions of ACH₅₀ and ELR₅₀.

Definitions:

$$ACH_{50} = \frac{CFM_{50} \times 60}{\text{Conditioned volume}}$$

$$ELR_{50} = \frac{CFM_{50}}{\text{Shell Area}}$$

ACH₅₀: Air Changes per Hour at 50 Pascals

ELR₅₀: Envelope Leakage Rate at 50 Pascals

CFM₅₀: Cubic feet per minute at 50 Pascals

CFM₅₀: Cubic feet per minute at 50 Pascals

60: 60 minutes

Shell Area: the combined square footage of conditioned floor, exterior walls, and insulated ceiling

Conditioned volume: the calculated volume of conditioned space

BE 3.0 Envelope leakage is ≤7 ACH₅₀ or ≤0.35 ELR, or reduce infiltration by >40% (requirement)

Criteria: Infiltration rate must be ≤7 ACH₅₀ or ≤0.35 ELR or achieve a reduction of >40% in air leakage for all tested units in certified projects. This is a requirement for all projects.

Additional Information:

- This rate must be achieved for all units tested. Testing may be completed using current RESNET Sampling requirements.
- All results for tested units must be posted, either at the electrical panel or HVAC return, in a place that is easily accessible for residents or maintenance staff but that does not obstruct utility information/access or will be removed.

Clarifications:

- Floor area must equal conditioned floor area used for the confirmed energy model.

Verification:

- The EarthCraft Technical Advisor will confirm compliance during final diagnostic testing and site inspections
- The EarthCraft Technical Advisor is responsible for posting diagnostic results in all tested units

BE 3.1 Envelope leakage is ≤ 5 ACH50 or ≤ 0.30 ELR (7 points)

Required for Platinum and Gold certification

Criteria: Infiltration rate of ≤ 5 ACH50 or ≤ 0.30 ELR for all tested units in projects following the Performance or Prescriptive energy efficiency pathways.

Additional Information:

- This rate must be achieved for all units tested. Testing may be completed using current RESNET Sampling requirements.
- All results for tested units must be posted, either at the electrical panel or HVAC return, in a place that is easily accessible for residents or maintenance staff but that does not obstruct utility information/access or will be removed.

Clarifications:

- Floor area must equal conditioned floor area used for the confirmed energy model.

Verification:

- The EarthCraft Technical Advisor will confirm compliance during final diagnostic testing and site inspections
- The EarthCraft Technical Advisor is responsible for posting diagnostic results in all tested units

BE 3.2 Envelope leakage is ≤ 3 ACH50 or ≤ 0.25 ELR (10 points)

Criteria: Infiltration rate of ≤ 3 ACH50 or ≤ 0.25 ELR for all tested units in projects following the Performance or Prescriptive energy efficiency pathways.

Additional Information:

- This rate must be achieved for all units tested. Testing may be completed using current RESNET Sampling requirements.
- All results for tested units must be posted, either at the electrical panel or HVAC return, in a place that is easily accessible for residents or maintenance staff but that does not obstruct utility information/access or will be removed.

Clarifications:

- Floor area must equal conditioned floor area used for the confirmed energy model.
- Projects achieving points in this section may not also achieve points in 3.1.

Verification:

- The EarthCraft Technical Advisor will confirm compliance during final diagnostic testing and site inspections
- The EarthCraft Technical Advisor is responsible for posting diagnostic results in all tested units

BE 4: Insulation

Insulation requirements are based on the total installed R-value of a project's preferred insulation product. The EarthCraft program does not set requirements for the type of insulation product(s) a project may choose to use, except for insulation products that are commonly known to contain hazardous materials, such as asbestos and lead. Installation quality and certain product specifications are identified within the program requirements in this section.

Minimum required R-values are set for all projects participating in the EarthCraft program, with credits available for projects that choose to install higher levels of insulation. At a minimum, projects must install insulation with an R-value that meets or exceeds the local code requirements set by the jurisdiction where the project is located. In cases where the EarthCraft requirement is more stringent than local code, the EarthCraft specified R-value and/or installation quality shall be met.

BE 4.0 Grade I insulation quality at all building envelope locations (requirement)

Criteria: Install insulation per manufacturer's recommendations to achieve quality Grade I as specified by criteria set forth by RESNET. This is a requirement for all projects.

Additional Information:

As will be noted throughout section BE 4, all insulation shall be installed to meet a Grade I quality, as defined in the Residential Energy Services Network (RESNET) Mortgage Industry National Home Energy Rating Systems (MINHERS), Continuous Maintenance Edition.

All current RESNET standards are available online at: <https://www.resnet.us/about/standards/minhers/>

Insulation grading criteria for each product type is listed below. These criteria is based on:

- Standard ANSI/RESNET/ICC 301-2014 [Addendum F, Appendix A: Inspection Procedures for Insulation Grading and Assessment](#), dated July 1, 2019

"Minimum General Installation Requirements:

- Insulation shall be installed to manufacturers' recommendations.
- No air spaces shall be allowed between different insulation types or systems.
- Insulation shall be installed to the required density and thickness necessary to achieve the labeled R-Value.
- Insulation shall fill around obstructions including, but not limited to, framing, blocking, wiring, pipes, etc. without substantial gaps or voids."

Grade I Insulation Criteria

"Grade I (Minor Defects) Shall meet ASTM-specified installation requirements in the applicable standards C1015, C1320 and ASTM C1848, and shall meet the following appropriate material installation grading requirements:

Batt or Loose-fill Insulation

- When installing batt, or loose-fill insulation, no more than 2% of the total insulated area shall be compressed below the thickness required to attain the labeled R-Value or contain gaps or voids in the insulation.
- These areas shall not be compressed more than 3/4 inch of the specified insulation thickness in any given location.
- Voids extending from the interior to exterior of the intended insulation areas shall not be permitted.

Open-Cell Polyurethane Spray Foam Insulation (cavity not filled and not trimmed)

- When installing open-cell polyurethane spray foam the average of all thickness measurements shall be greater than the specified thickness required to obtain the specified R-Value.
- No more than 2% of the insulated area shall contain voids or be more than 3/4 inch below the specified thickness.
- The minimum installed thickness shall not be less than 1 inch below the specified thickness at any point. Voids extending from the interior to the exterior of the intended insulation areas shall not be permitted.

Open-Cell Polyurethane Spray Foam Insulation (cavity filled and trimmed)

- When installing open-cell polyurethane spray foam, no more than 2% of the total insulated area (cavity) shall be below the thickness required to attain the specified thickness or contain gaps or voids in the insulation.
- The minimum installed thickness shall not be less than 1/2 inch below the specified thickness at any point.
- Voids extending from the interior to exterior of the intended insulation areas shall not be permitted.

Closed-Cell Polyurethane Spray Foam

- When installing closed-cell polyurethane spray foam the average of all thickness measurements shall be greater than the specified thickness required to obtain the specified R-Value.
- No more than 2% of the insulated area shall contain voids or be greater than 1/2 inch less than the specified thickness.
- The minimum installed thickness shall not be less than 3/4 inch below the specified thickness at any point.
- Voids extending from the interior to exterior of the intended insulation areas shall not be permitted.

Insulated Sheathing

- Insulated sheathing insulation installations meeting the minimum installation, application, and material requirements above.
- Voids exceeding 1/8" through interior to exterior of the intended insulation areas shall not be permitted.
- Joints and other gaps or separations in sheathing used as an air barrier, vapor retarder or drainage plane shall be taped or sealed."

Verification:

- The EarthCraft Technical Advisor will confirm compliance during mid-construction and final site inspections

BE 4.1 If using loose-fill attic insulation: insulation certificate posted at access door and insulation rulers installed 1 per 300 ft² (requirement)

Criteria: Projects with unconditioned, insulated attics must post insulation certificates at each attic area and insulation rulers spaced throughout the attic(s) with at least 1 ruler for every 300 ft².

Clarifications:

- Certificate(s) must include, at a minimum, the following information:
 - Installer company
 - Date of installation
 - Insulation product manufacturer and material(s)
 - Installed insulation depth
 - Installed insulation R-value
- Rulers must be installed so that they are easily visible from primary attic access doors and/or access pathways. Rulers must be installed so that the bottom of the ruler is level with the attic floor. Rulers must clearly show insulation depth markers in inches and, if applicable, equivalent R-value of selected product.

Verification:

- The EarthCraft Technical Advisor will confirm compliance during final site inspections.

BE 4.2 Fibrous insulation is unfaced/friction fit (requirement)

Criteria: If fibrous insulation is used in exterior wall assemblies (cellulose or fiberglass), it must be unfaced.

Clarifications:

- Batt insulation in all exterior wall assemblies shall be unfaced and installed using friction fit installation techniques between studs and joists.
- Blown insulation in all exterior wall assemblies may be netted or spray applied
- If a spray foam insulation product is used it shall be installed to meet manufacturer specifications

Verification:

- The EarthCraft Technical Advisor will confirm compliance during mid-construction site inspections

BE 4.3 Exterior Wall Insulation (requirement)

Criteria: Insulation in flooring separating conditioned spaces from unconditioned areas shall meet minimum R-values based on construction type(s) and geographical location. This is a requirement for all projects.

Unless specifically noted, all insulation shall be installed to meet a RESNET Grade I quality per BE 4.0.

BE 4.3.1. Exterior walls and band joist $\geq R-13$

- Install insulation on all exterior walls to $\geq R-13$ using insulation product(s) that meet the insulation value within the wall cavity or through a combination of cavity and continuous exterior insulation.
- If insulating a steel joist wall, R-7.5 continuous insulation must be installed in addition to floor insulation listed above (refer to BE 4.9 for more information)

BE 4.3.2. Fireplace chase(s) on exterior walls $\geq R-13$

- Exterior fireplace chase which connects to conditioned space must be insulated to $\geq R-13$. Insulation must be in continuous contact with exterior walls and ceiling above. Insulation must be located no closer than 1" to the flue pipe, or according to local code, whichever is more stringent.
- If insulating a steel joist floor, R-7.5 continuous insulation must be installed in addition to floor insulation listed above (refer to BE 4.9 for more information)

BE 4.3.3. Foundation walls:

- Climate Zone 2/3: $\geq R-5$ continuous or $\geq R-13$ cavity
- Climate Zone 4: $\geq R-10$ continuous or $\geq R-13$ cavity

Additional Information:

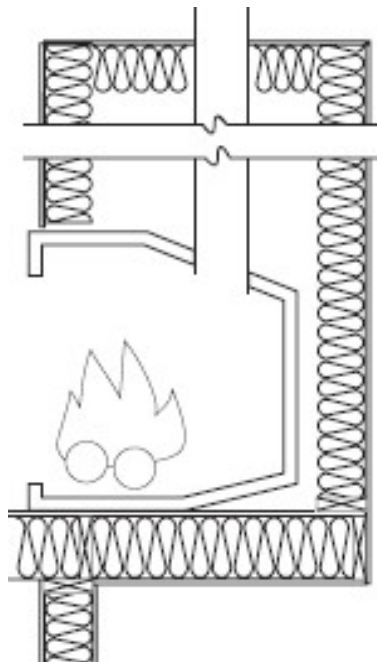

Insulation shall be installed behind fireplace walls along exterior walls in all residences and/or common areas.

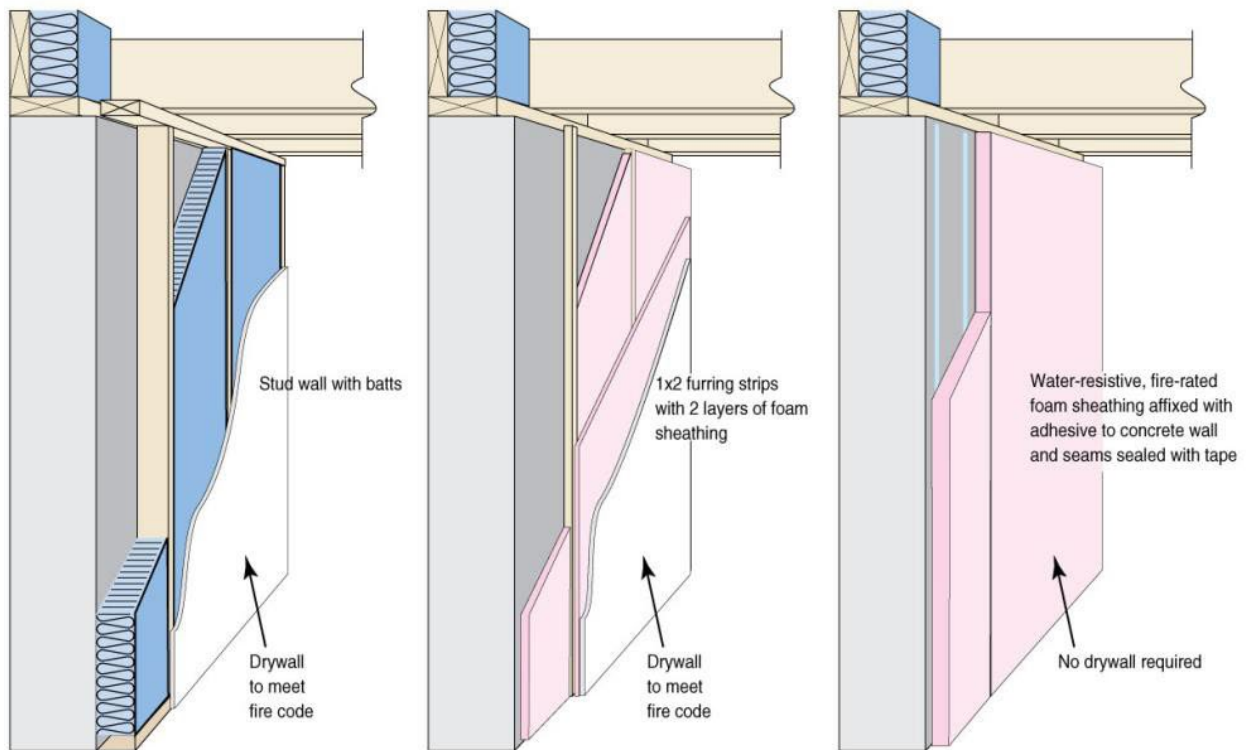

Insulation shall be installed to below-grade walls as either cavity insulation in framed walls or continuous insulation.

Clarifications:

- If insulating a steel studded wall or steel header, R-7.5 continuous insulation must be installed in addition to wall insulation listed above.
- Garage walls are considered exterior walls.
- Foundation walls require insulation if inside building thermal envelope. Insulation must be in permanent contact with foundation wall.

Verification:

- The EarthCraft Technical Advisor will confirm compliance during mid-construction and final site inspections

BE 4.4 Ceiling Insulation (requirement)

Criteria: Ceilings insulated with fibrous insulation products shall meet minimum R-value requirements based on location of insulation. This is a requirement for all projects.

Unless specifically noted, all insulation shall be installed to meet a RESNET Grade I quality per BE 4.0.

BE 4.4.1. Ceilings with Attic Space: Zone 1/2/3 \geq R-38; Climate Zone 4/5 \geq R-49

- **Criteria:** Insulate flat and/or sloped ceilings to a minimum R-38 or R-49 based on climate zone, including areas beneath attic access walkways/storage.

BE 4.4.2. Vaulted/flat, unvented attic roofline with air impermeable material: Climate Zone 1/2/3 \geq R-21; Climate Zone 4/5 \geq R-25

- **Criteria:** Insulate rooflines (above or below decking) to a minimum R-21 or R-25 based on climate zone using air impermeable insulation products, such as spray foam or foam board products

BE 4.4.3. Continuous exterior insulation above roof decking: Climate Zone 1/2/3 \geq R-25; Climate Zone 4/5 \geq R-30

- **Criteria:** Insulate rooflines using air permeable cavity insulation (Ex. Fiberglass or cellulose) with continuous exterior insulation to R-25 or R-30 based on climate zone.

Additional Information:

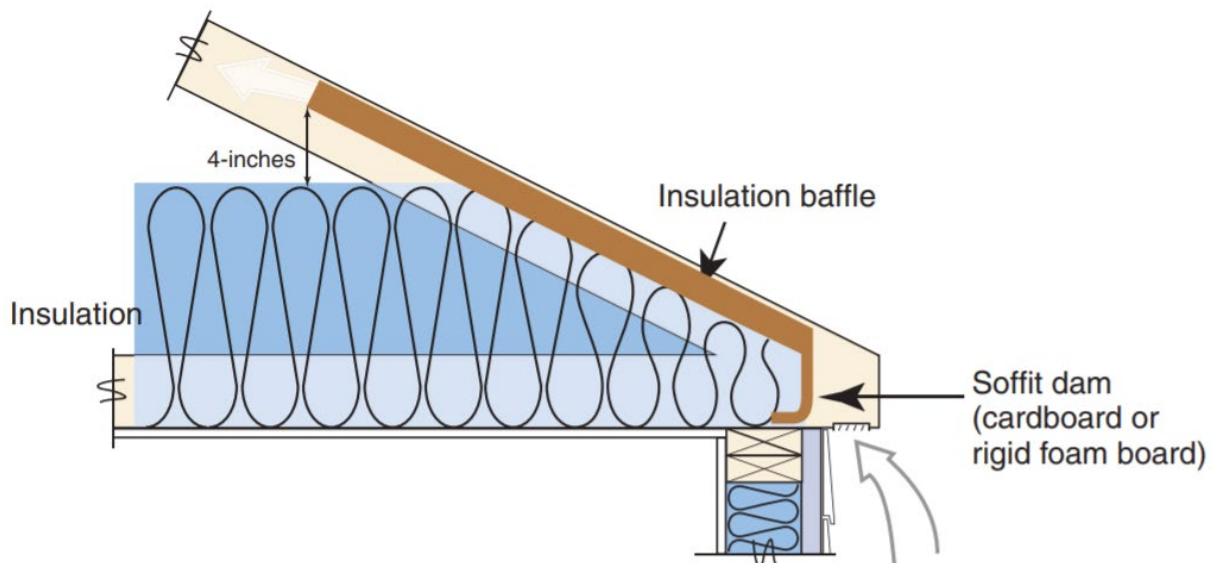

Insulation installed in a standard truss system, with tapering at edges along roof decking. Insulation product (pictured here is an example of a fibrous insulation product, such as fiberglass batts or blow-in fiberglass insulation), shall be installed so that it covers the outermost edge of the perimeter top plate so as to reduce the thermal gap between exterior walls and the attic above. Where necessary, insulation baffles shall be installed to separate insulation from soffit vents per BE 4.3.1.

Image Credit: Southface GA 2020 Residential Field Guide: <https://4553qr1wvuj43kndml31ma60-wpengine.netdna-ssl.com/wp-content/uploads/2019/09/GA-2020-Residential-Field-Guide.pdf>

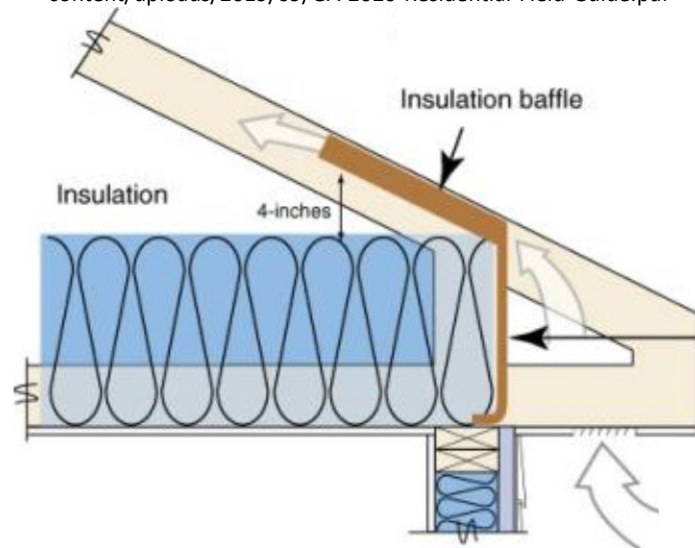

Insulation product (pictured here is an example of a fibrous insulation product, such as fiberglass batts or blow-in fiberglass insulation), shall be installed so that it covers the outermost edge of the perimeter top plate so as to reduce the thermal gap between exterior walls and the attic above. Energy heel truss systems provide additional height in these areas to allow for insulation coverage to meet R-38 goals. Where necessary, insulation baffles shall be installed to separate insulation from soffit vents per BE 4.3.1.

Image Credit: Southface GA 2020 Residential Field Guide: <https://4553qr1wvuj43kndml31ma60-wpengine.netdna-ssl.com/wp-content/uploads/2019/09/GA-2020-Residential-Field-Guide.pdf>

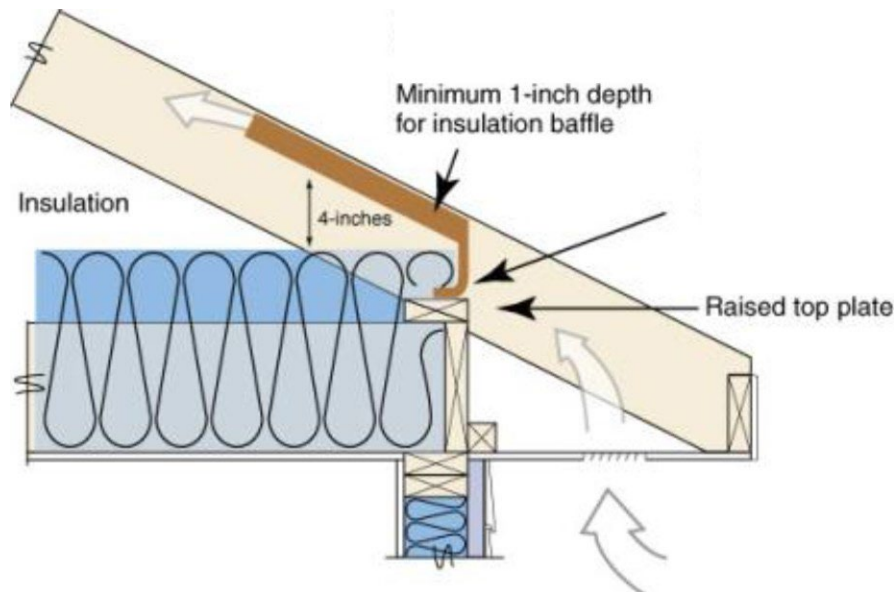

Insulation product (pictured here is an example of a fibrous insulation product, such as fiberglass batts or blow-in fiberglass insulation), shall be installed so that it covers the outermost edge of the perimeter top plate so as to reduce the thermal gap between exterior walls and the attic above. Raised top plates provide additional height in these areas to ensure insulation depth meets R-38 goals. Where necessary, insulation baffles shall be installed to separate insulation from soffit vents per BE 4.3.1.

Image Credit: Southface GA 2020 Residential Field Guide: <https://4553qr1wvuj43kndml31ma60-wpengine.netdna-ssl.com/wp-content/uploads/2019/09/GA-2020-Residential-Field-Guide.pdf>

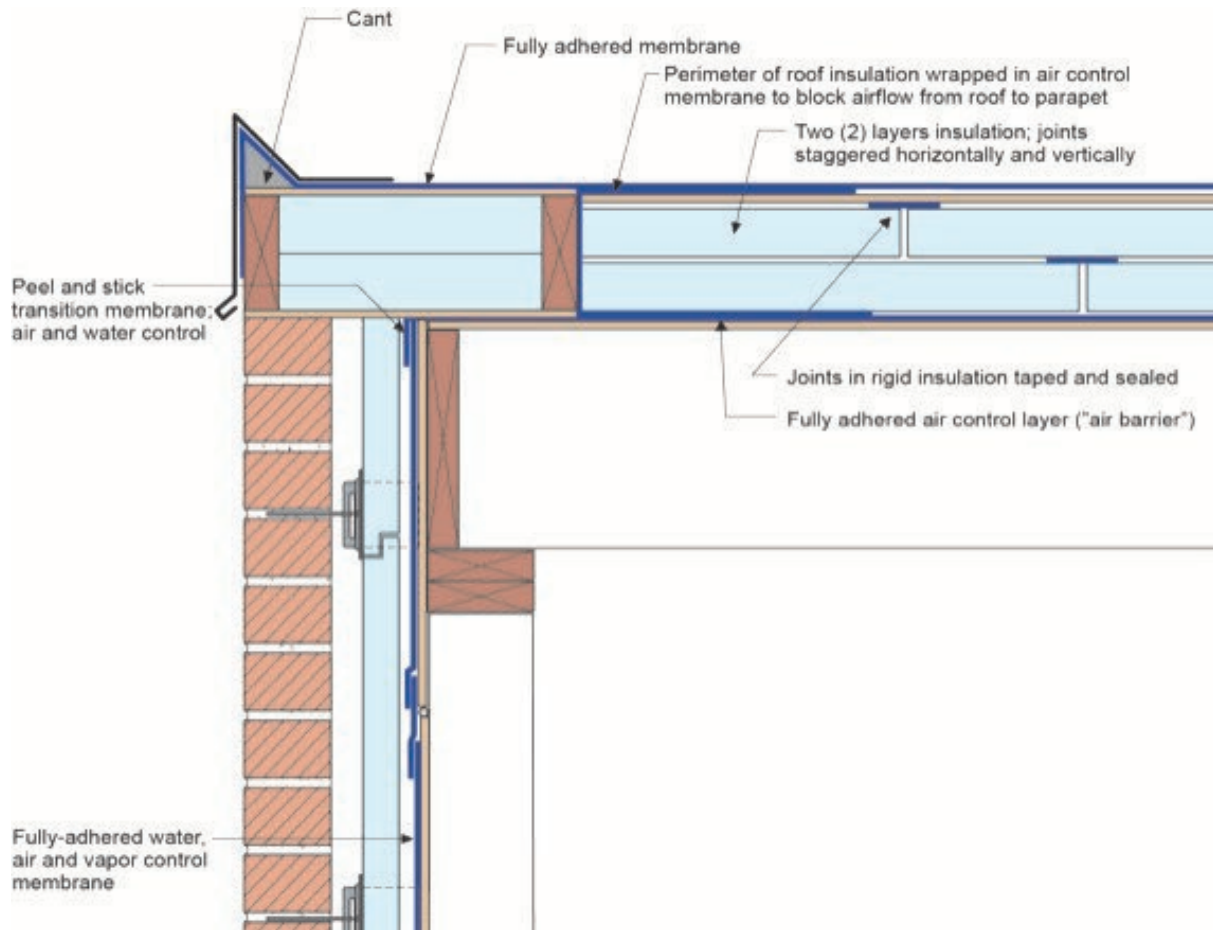

Insulation installed above roof decking on flat roofs shall extend past the outermost edge of the exterior wall to minimize the thermal gap between the wall/roof intersection. Insulation boards, demonstrated above, shall be installed with overlapping joints that are taped at all seams. The roof membrane shall be integrated with drainage plane to prevent water intrusion at edge of building.

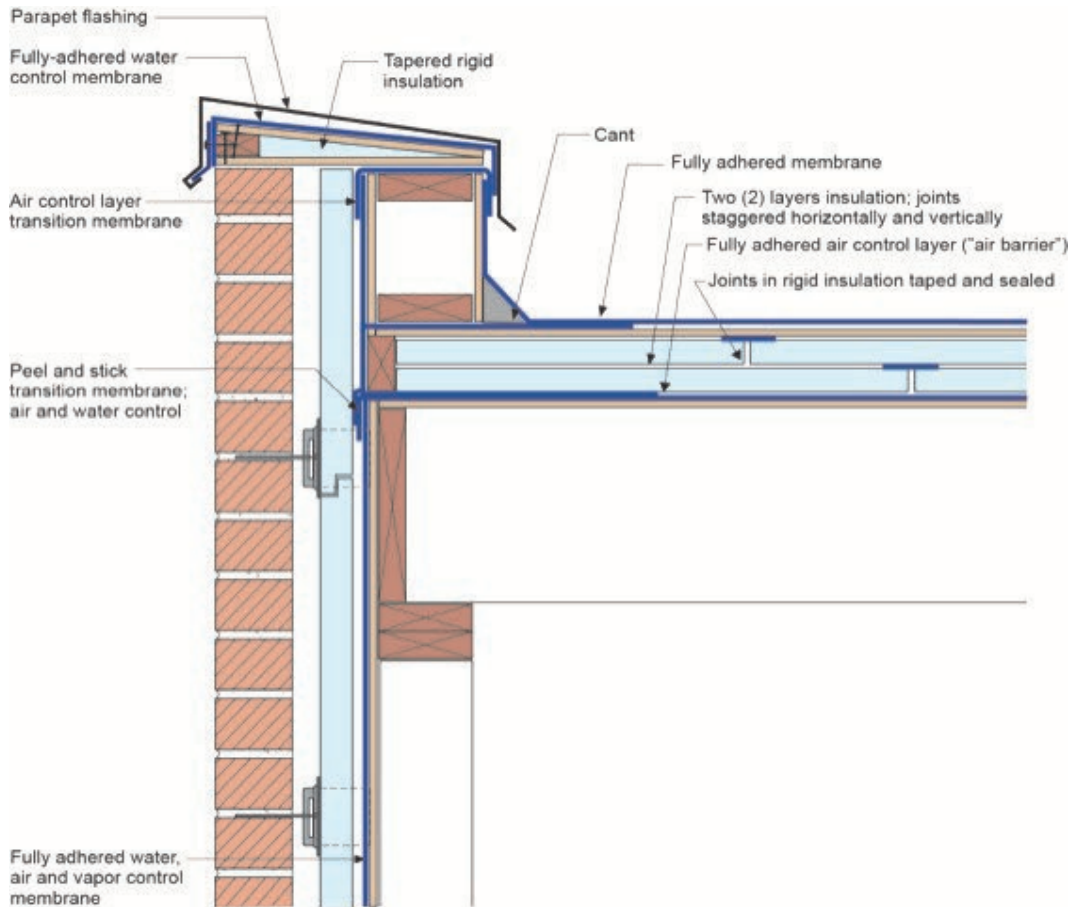

Insulation installed above roof decking on flat roofs shall extend past the outermost edge of the exterior wall to minimize the thermal gap between the wall/roof intersection. Insulation boards, demonstrated above, shall be installed with overlapping joints that are taped at all seams. The roof membrane shall be integrated with drainage plane at parapet wall to prevent water intrusion at edge of building.

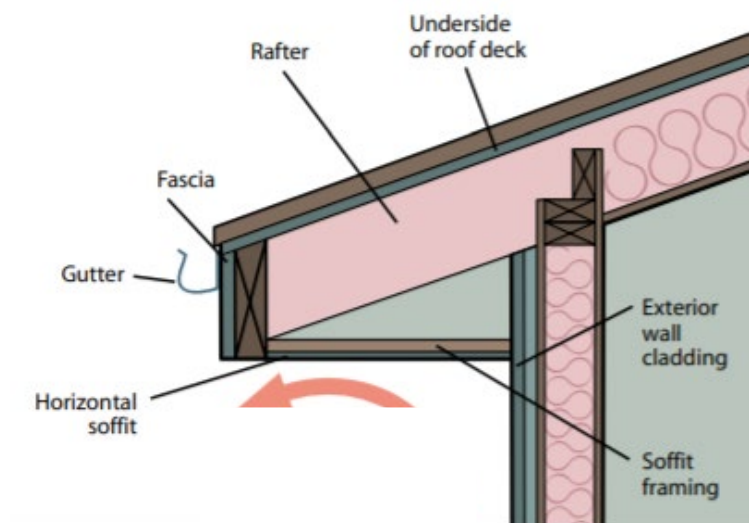

Insulation installed along the underside of a sloped roof (such as spray applied or batt insulation) shall be installed in contact with roof decking and extend to exterior wall.



Photo Image of spray applied foam insulation along roof decking.

Image Credits: Building America Solution Center:

Verification:

- The EarthCraft Technical Advisor will confirm compliance during mid-construction and final site inspections

BE 4.5 Unconditioned attics (requirement)

Criteria: Unconditioned attics shall be constructed to allow for maximum insulation coverage over conditioned areas. This is a requirement for all projects.

BE 4.5.1. Install wind baffles at eaves in every bay, or equivalent air barrier at edge of ceiling

- **Criteria:** Install wind baffles or blocking at eaves to prevent wind washing over insulation. Include a baffle in every bay or a tabbed baffle in each bay with a soffit vent that will also prevent wind washing of insulation in adjacent bays.

BE 4.5.2. Attic platforms allow for full-depth insulation below

- **Criteria:** Raise attic platforms to allow for full depth of insulation below in order to meet minimum flat ceiling R-value requirement. Access to equipment or storage space on attic platform(s) must be maintained without compressing insulation.

BE 4.5.3 When installing loose-fill attic insulation, card and rulers must be installed

- **Criteria:** Install attic rulers facing the attic entrance every 300 sq ft to verify insulation depth. Post written documentation in the attic (an “attic card”) specifying the insulation type, coverage area, and R-value in an area easily accessible from the primary attic door/opening. This is a requirement for all projects.

Additional Information:

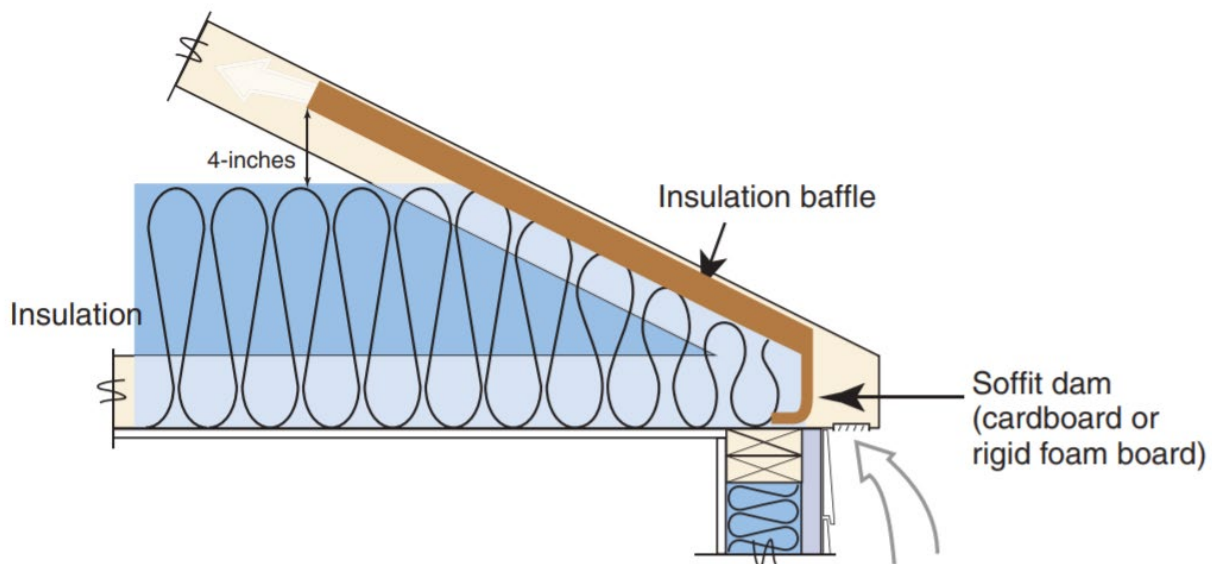

Insulation installed in a standard truss system, with tapering at edges along roof decking. Insulation product (pictured here is an example of a fibrous insulation product, such as fiberglass batts or blow-in fiberglass insulation), shall be installed so that it covers the outermost edge of the perimeter top plate so as to reduce the thermal gap between exterior walls and the attic above. Where necessary, insulation baffles shall be installed to separate insulation from soffit vents.

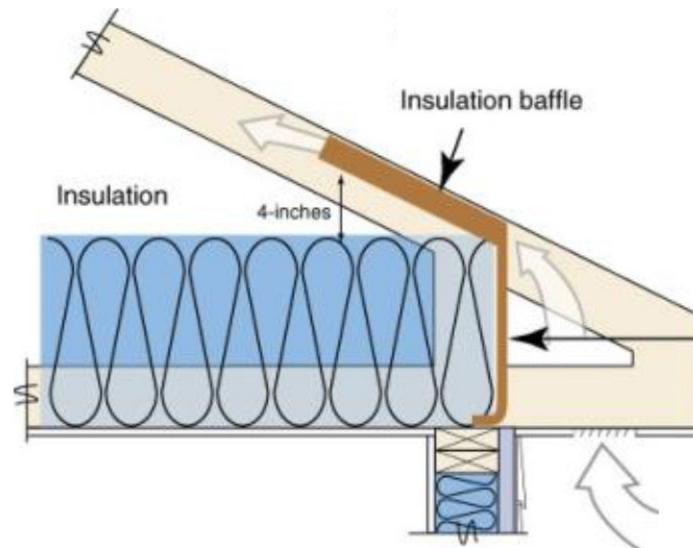

Insulation product (pictured here is an example of a fibrous insulation product, such as fiberglass batts or blow-in fiberglass insulation), shall be installed so that it covers the outermost edge of the perimeter top plate so as to reduce the thermal gap between exterior walls and the attic above. Energy heel truss systems (points in BE 4.14) provide additional height in these areas to allow for insulation coverage to meet R-38 goals. Where necessary, insulation baffles shall be installed to separate insulation from soffit vents per BE 4.3.1.

Image Credit: Southface GA 2020 Residential Field Guide: <https://4553qr1wvuj43kndml31ma60-wpengine.netdna-ssl.com/wp-content/uploads/2019/09/GA-2020-Residential-Field-Guide.pdf>

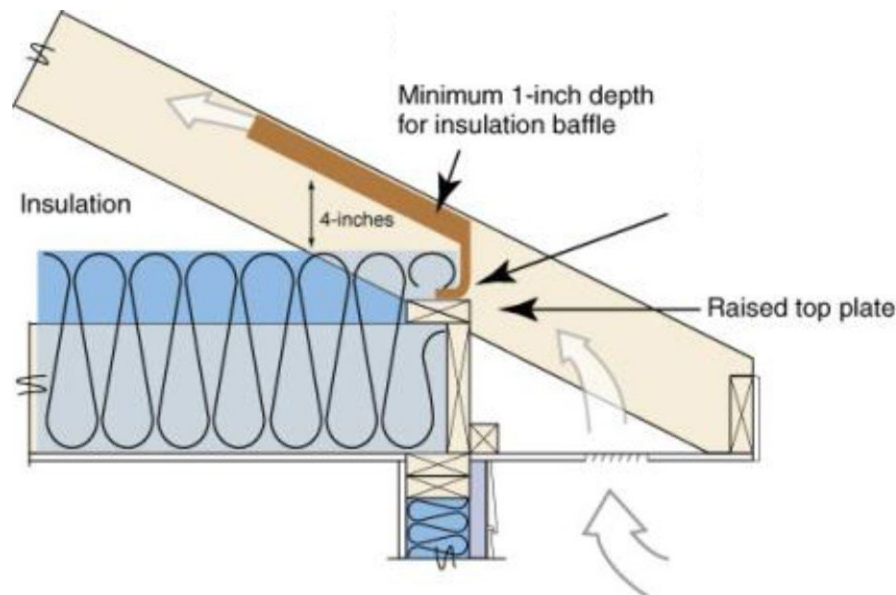

Insulation product (pictured here is an example of a fibrous insulation product, such as fiberglass batts or blow-in fiberglass insulation), shall be installed so that it covers the outermost edge of the perimeter top plate so as to reduce the thermal gap between exterior walls and the attic above. Raised top plates (points in **BE 4.14**) provide additional height in these areas to ensure insulation depth meets R-38 goals. Where necessary, insulation baffles shall be installed to separate insulation from soffit vents per BE 4.3.1.

Image Credit: Southface GA 2020 Residential Field Guide: <https://4553qr1wvuj43kndml31ma60-wpengine.netdna-ssl.com/wp-content/uploads/2019/09/GA-2020-Residential-Field-Guide.pdf>

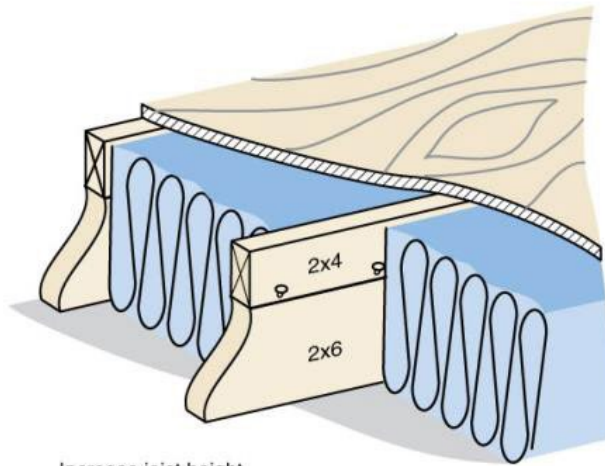

Increase joist height
under decking to raise R-value
for ceiling

Attic areas with storage shall have raised platforms that allow for R-38 insulation coverage beneath them. Insulation in these areas shall be installed prior to securing the storage decking (or prior to the installation of drywall below) in place to ensure proper insulation coverage and quality.

Verification:

- The EarthCraft Technical Advisor will confirm compliance during mid-construction and final site inspections

BE 4.6 Attic knee wall (requirement)

Criteria: Attic knee walls shall be air sealed and insulated to fully separate conditioned spaces from unconditioned attics. This is a requirement for all projects.

BE 4.6.1. Doors: Climate Zone 2/3/4 $\geq R-18$

- **Criteria:** Insulate doors separating conditioned space from unconditioned attic spaces to R-18 or greater in Climate Zones 2, 3, and 4.
 - Attic knee wall doors must allow for full depth of minimum R-value insulation when opened, thus preventing damage of insulation over time.

BE 4.6.2. Insulation and attic side air barrier: Climate Zone 2/3/4 $\geq R-18$

- **Criteria:** Insulate knee walls separating conditioned space from unconditioned attic space to R-18 or greater in Climate Zones 2, 3 and 4. Insulation must be in contact with attic side air barrier.
 - Install rigid attic side air barrier (e.g., foam board, plywood, OSB) along all knee walls separating conditioned space from unconditioned attic space.
 - Air barrier(s) must align with entire height of attic knee wall to provide full insulation encapsulation on all six (6) sides.
 - Block band and air seal joist cavities beneath knee walls to eliminate air leakage pathways and ensure proper attic floor insulation coverage.

Additional Information:

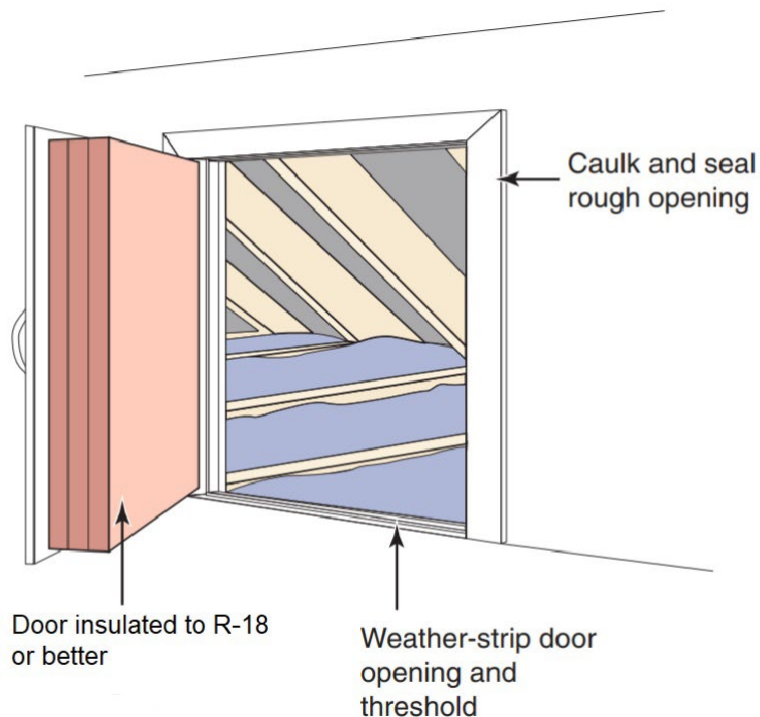

Insulate knee wall doors to $\geq R-18$ with an insulation product that may be permanently attached to the door.

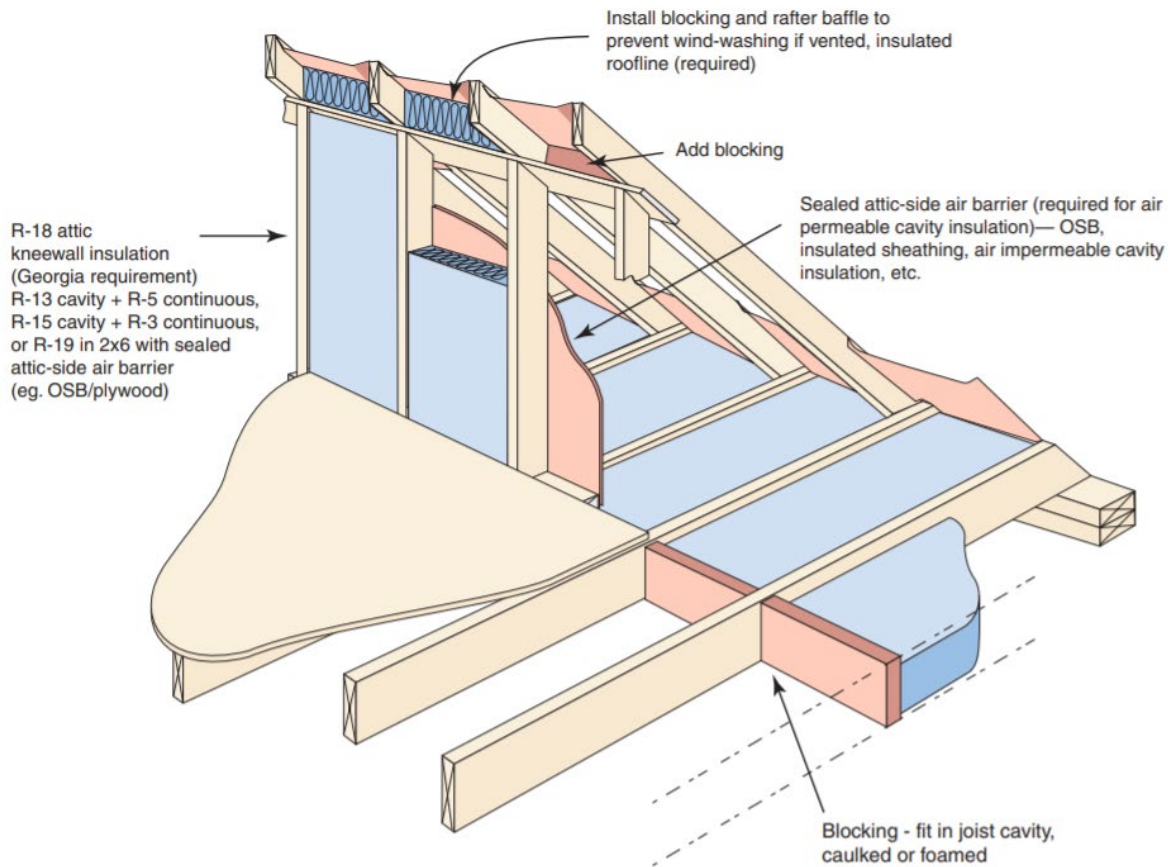

Attic knee walls shall be air sealed, insulated and sheathed to eliminate air leakage pathways and maximize insulation coverage in these areas.

Image Credit: Georgia 2020 Residential Field Guide, p.g. 33, <https://4553qr1wvuj43kndml31ma60-wpengine.netdna-ssl.com/wp-content/uploads/2019/09/GA-2020-Residential-Field-Guide.pdf>

Verification:

- The EarthCraft Technical Advisor will confirm compliance during mid-construction and final site inspections

BE 4.7 Attic pull-down/scuttle hole located in conditioned space: Climate Zone 1/2/3 $\geq R-38$; Climate Zone 4/5 $\geq R-49$ (requirement)

Criteria: Install insulation, an insulated box or other cover equal to or greater than R-38 or R-49 based on climate zone for pull-down attic stairs separating conditioned space from unconditioned attic space. This is a requirement for all projects.

Additional Information:

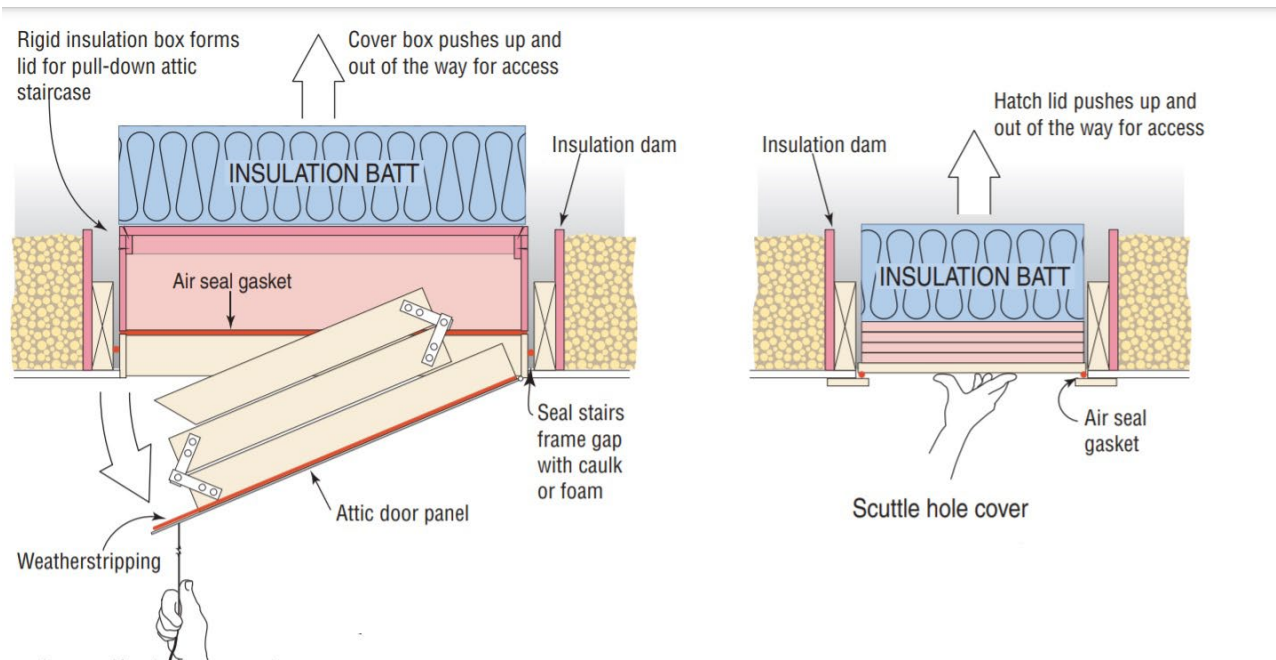

Unconditioned attic access doors that are in conditioned space shall be insulated to the same R-value as the surrounding attic, a minimum of R-38.

Image Credit: Georgia 2020 Residential Field Guide, p.g. 30, <https://4553qr1wvuj43kndml31ma60-wpengine.netdna-ssl.com/wp-content/uploads/2019/09/GA-2020-Residential-Field-Guide.pdf>

Clarifications:

- Insulation must completely cover the rough opening of pull-down stairs. Compressed batts are not acceptable.

Verification:

- The EarthCraft Technical Advisor will confirm compliance during mid-construction and final site inspections

BE 4.8 Floor Insulation (requirement)

Criteria: Insulation in flooring separating conditioned spaces from unconditioned areas shall meet minimum R-values based on construction type(s) and geographical location. This is a requirement for all projects.

Unless specifically noted, all insulation shall be installed to meet a RESNET Grade I quality per BE 4.0

BE 4.2.1. Framed \geq R-19

- Insulate framed floor separating conditioned enclosed unconditioned spaces to R-19 or greater.
- If using a fibrous batt insulation, permanent support must be installed to keep the product in contact with the subfloor of the conditioned space above.
- If insulating a steel joist floor, R-7.5 continuous insulation must be installed in addition to floor insulation listed above (refer to BE 4.9 for more information)

BE 4.2.2. Cantilevered/other exterior spaces \geq R-30

- Block between joists and insulate all floors with conditioned space over ambient areas to R-30 or greater.
- If using a fibrous batt insulation, the product shall fill cavity to ensure contact with subfloor of the conditioned space above after exterior finish has been installed.
- Blocking between joists is required when joists cross from unconditioned spaces to conditioned spaces.
- If insulating a steel joist floor, R-7.5 continuous insulation must be installed in addition to floor insulation listed above (refer to BE 4.9 for more information)

BE 4.2.3. Podium/elevated slabs \geq R-19

- Insulate podiums or elevated slabs over enclosed unconditioned spaces to R-19 or greater.
- Insulate podiums or elevated slabs over ambient areas to R-30 or greater
- If using a fibrous batt insulation, support must be installed to keep product in contact with the subfloor of the conditioned space above.

Additional Information:

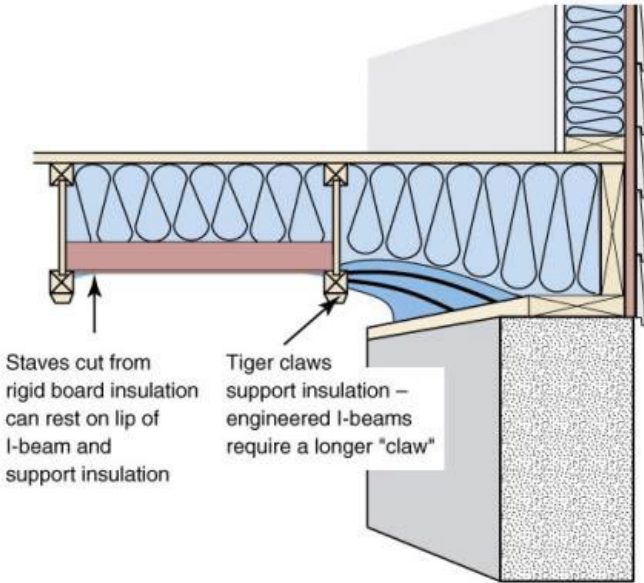

Framed floor insulation shall be installed to fit between each framing member and be installed in contact with subfloor of conditioned space above. Supports may include strapping, wire "tiger claws" or a solid barrier to support the insulation product from the underside.

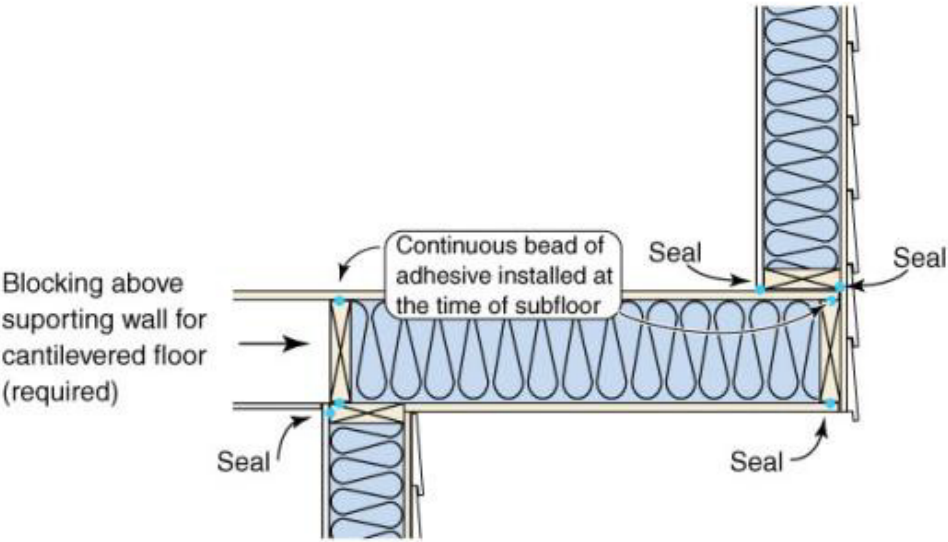

Floor insulation in cantilevers shall be installed so that the insulation product remains in contact with the subfloor of the conditioned space above. Blocking shall be installed to meet BE 2.1.2.

Clarifications:

- Insulation must be in permanent contact with subfloor, or a fully aligned air barrier on the exterior side of the conditioned space provided that the perimeter rim and band joists of the floor cavity are also sealed and insulated to comply with the insulation and air sealing requirements for walls.
- Framed floors over basement/crawlspace require insulation only if basement/crawlspace is unconditioned and outside of building envelope.
- Trade-off to R-19 or greater is allowed in cantilevered floors/floors over ambient exterior spaces if an air resistant insulation product is used (Ex. Spray foam insulation products).
- Enclosed unconditioned spaces typically include vented crawlspace, unconditioned basement, garage, etc.
- Conditioned spaces over ambient areas typically include floors over carports, cantilevered floors, etc.

Verification:

- The EarthCraft Technical Advisor will confirm compliance during mid-construction and final site inspections

BE 4.9 Steel-framed buildings require thermal break \geq R-7.5 (requirement)

Criteria: All steel-framed buildings must be insulated with continuous exterior insulation greater than or equal to R-7.5. This is a requirement for all projects.

Clarifications:

- Exterior insulation is required on all walls separating conditioned spaces from unconditioned areas, including ambient environment, garages, and attics.

Verification:

- The EarthCraft Technical Advisor will confirm compliance during mid-construction and final site inspections

BE 4.10 Slab edge insulation: Climate Zone 2/3 \geq R-5, Climate Zone 4 \geq R-10 (3 points)

Criteria: Install exterior slab insulation (Climate Zone 2/3 \geq R-4 [heated slabs \geq R-5], Climate Zone 4 \geq R-10 [heated slabs \geq R-15]) so that it extends to the top of the slab. Slab edge insulation must extend to the bottom of the footing or 2', whichever is less.

Additional Information:

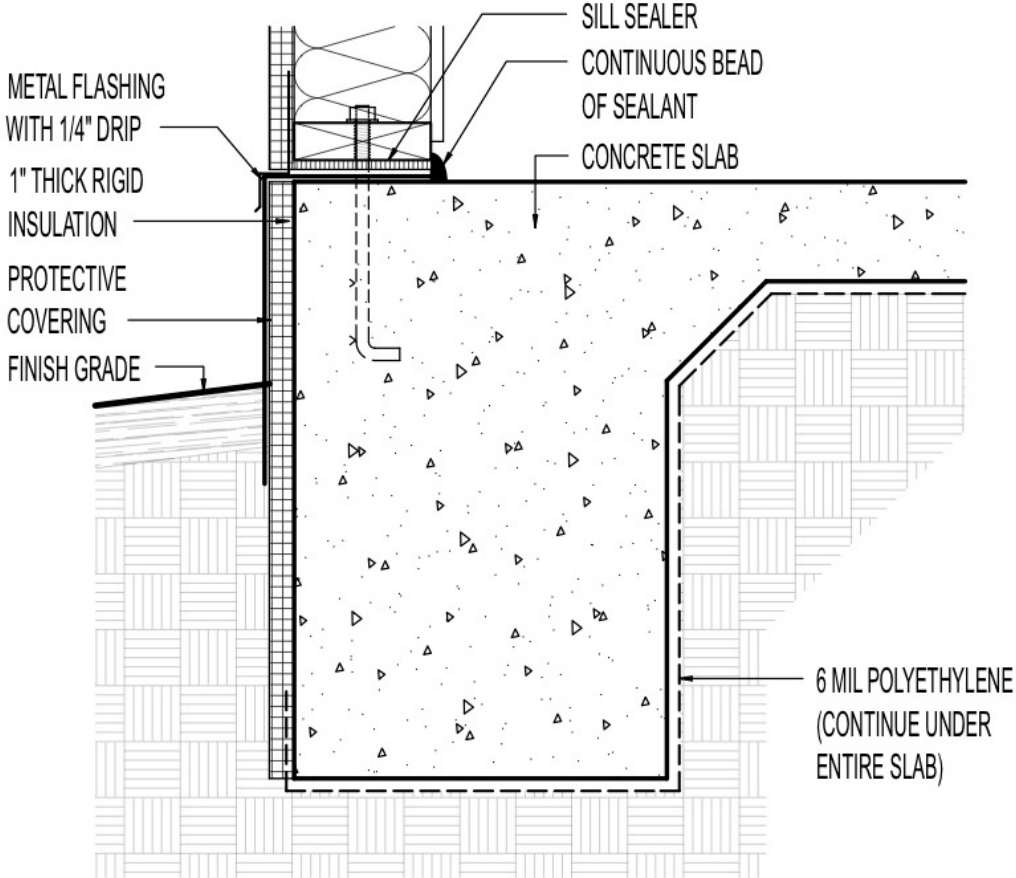

Slab edge insulation installed at the exterior of a monolithic slab with grade beam. Insulation shall be installed in contact with the exterior of the slab and extending to the top of the concrete.

Image Credit: Building America Solution Center, Slab Edge Insulation, <https://basc.pnnl.gov/resource-guides/slab-edge-insulation#edit-group-description>

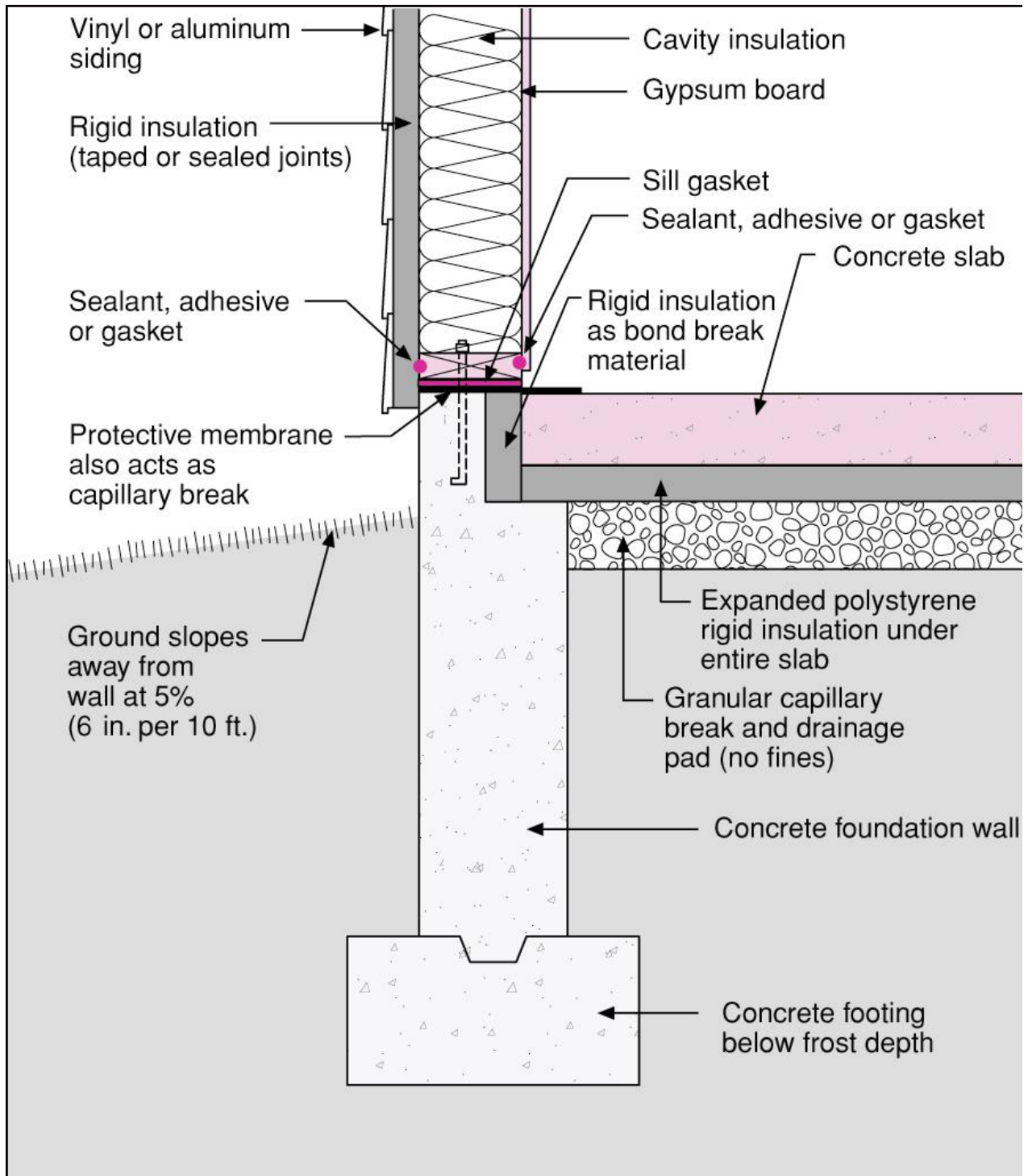

Slab insulation installed beneath slabs that are placed independently from the foundation wall.

Image Credit: Building America Solution Center, Slab Edge Insulation, <https://basc.pnnl.gov/resource-guides/slab-edge-insulation#edit-group-description>

Clarifications:

- Where an insulated wall separates a garage, patio, porch or other unconditioned space from the conditioned space of the building, slab insulation shall also be installed at this interface to provide a thermal break between the conditioned and unconditioned slab, unless the slab is post-tensioned with integrated garage or porch foundations.
- For exterior slab edge insulation, such as for monolithic slabs, install insulation with approved membranes, such as EPDM-type membranes, to protect against termites.
- Non-monolithic slabs may use rigid insulation between the stem wall and the poured (floating) slab, using the protective membrane as a termite flashing and as a capillary break.
- If the top edge of the insulation is installed between the exterior wall and the edge of the interior slab, it may be cut at a 45-degree angle away from the exterior wall.

Exemptions:

- Slab edge insulation is not required in jurisdictions designated by the local code official as having a very heavy termite infestation.
- Slabs greater than 12" below grade as measured from the top of the slab are not required to have insulation.

Verification:

- The EarthCraft Technical Advisor will confirm compliance during mid-construction and final site inspections
- The EarthCraft Technical Advisor will review photo documentation provided by the project team at mid-construction

BE 4.11 Corners $\geq R-6$ (3 points)

Criteria: Insulate the intersecting corner of two walls separating conditioned and unconditioned space to greater than or equal to R-6 so that insulation is continuous in the external wall.

Additional Information:

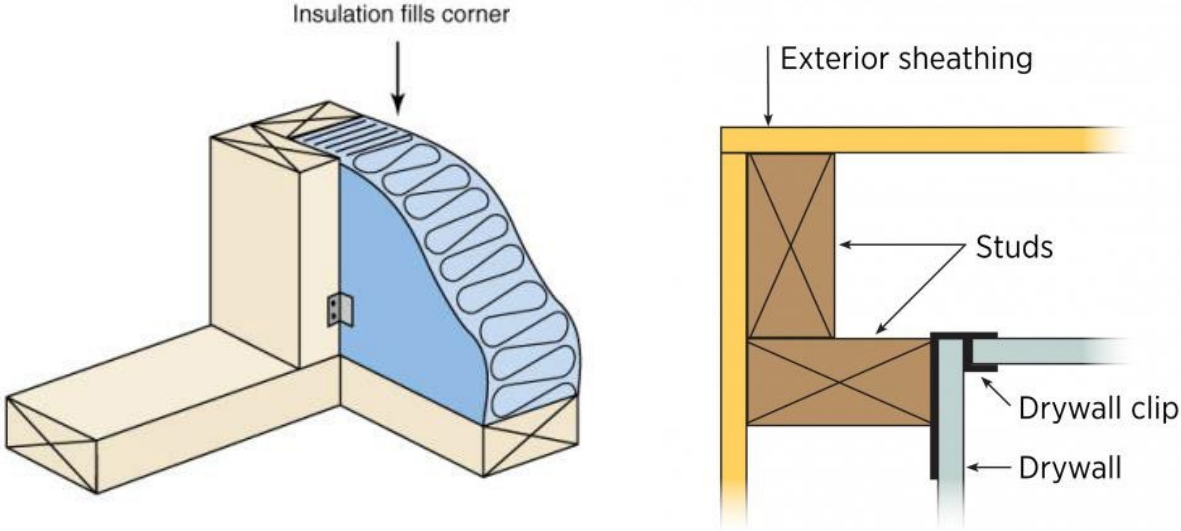

Wall framing that allows for maximum insulation coverage is preferred.

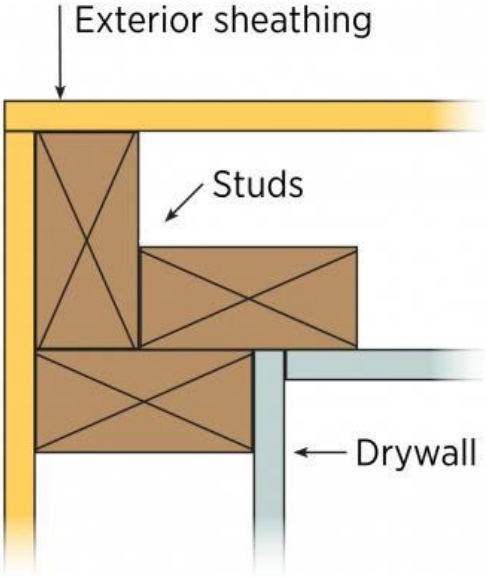

Improved three-stud corners that allow insulation to be installed in at least 1/2 of the cavity are allowed to achieve points under this credit.

Image Credits: Building America Solution Center, Advance Framing: Insulated Corners, <https://basc.pnnl.gov/resource-guides/advanced-framing-insulated-corners#edit-group-description>

Clarifications:

- The corner must be fully insulated to achieve the intent; therefore, corners with more than three studs are not permitted.
- Corners that are load bearing, such as for porch roofs or in areas deemed necessary for additional framing by the project structural engineer, are not required to meet this requirement for projects seeking Gold or Platinum certification.
- Project must have $\geq 75\%$ of exterior corners insulated to achieve points, including all corners that are not restricted due to load considerations.

Verification:

- The EarthCraft Technical Advisor will confirm project understands credit requirements during Design Review meeting.
- The EarthCraft Technical Advisor will confirm compliance during mid-construction and final site inspections

BE 4.12 Headers ≥R-5 (3 points)

Criteria: Insulate all headers on walls separating conditioned and unconditioned space to greater than or equal to R-5.

Insulated headers

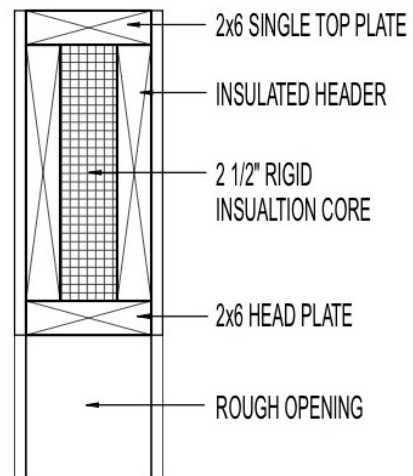
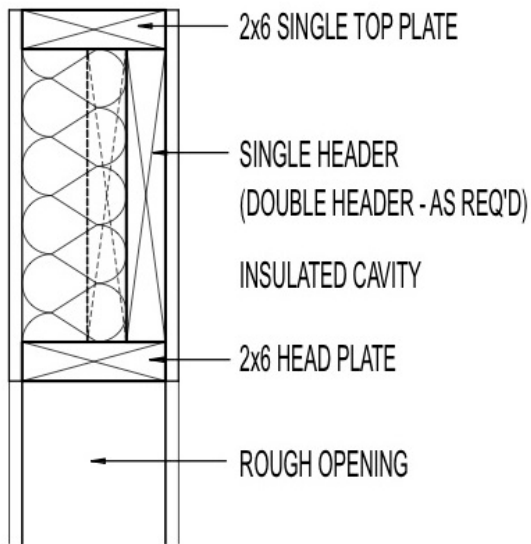
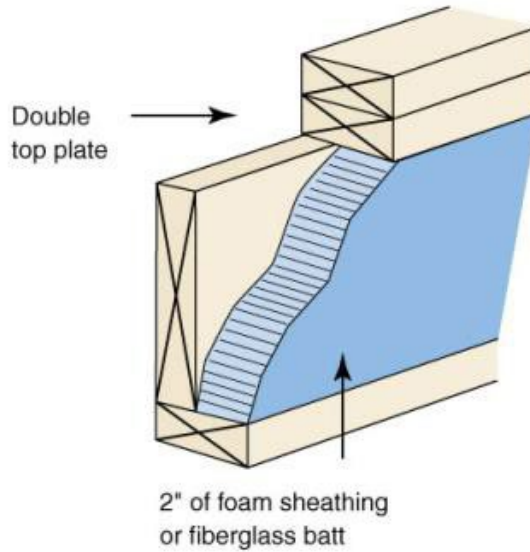
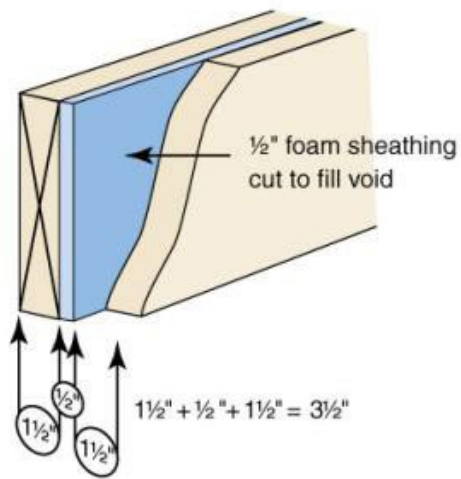

Header insulation shall be a minimum R-3 and may be accomplished through a variety of methods.

Image Credits: Building America Solution Center, Advanced Framing: Insulated Headers, <https://basc.pnnl.gov/resource-guides/advanced-framing-insulated-headers#edit-group-scope>

Clarifications:

- The R-value requirement refers to the insulation manufacturer's nominal insulation value.

Exemptions:

- Headers on exterior walls where the structural engineered framing layout indicates that full-depth solid headers are the only acceptable option are exempt from being insulated.

Verification:

- The EarthCraft Technical Advisor will confirm project understands credit requirements during Design Review meeting.
- The EarthCraft Technical Advisor will confirm compliance during mid-construction and final site inspections

BE 4.14 Improved exterior wall insulation R-value

Criteria: Improve exterior wall insulation coverage above minimum EarthCraft requirements. There are three options in this credit. Projects may only take points for one option.

BE 4.14.A. Wall cavity R-15 and R-3 continuous (10 points)

- Install wall stud cavity insulation to R-15 in all exterior framed walls and band joists adjacent to unconditioned spaces. Insulate all band joist areas between conditioned floors using R-15 insulation. Insulation must be installed using manufacturer recommendation for permanent alignment with band joist.
- Install R-3 continuous exterior insulation on all exterior walls.

BE 4.14.B. Wall cavity R-13 and R-5 continuous (10 points)

- Install wall stud cavity insulation to R-13 in all exterior framed walls and band joists adjacent to unconditioned spaces. Insulate all band joist areas between conditioned floors using R-13 insulation. Insulation must be installed using manufacturer recommendation for permanent alignment with band joist.
- Install R-5 continuous exterior insulation on all exterior walls.

BE 4.14.C. Insulate exterior walls and band joist \geq R-19 (10 points)

- Install wall stud cavity insulation to \geq R-19 or greater in all exterior framed walls and band joists adjacent to unconditioned spaces.
- Insulate all band joist areas between conditioned floors using \geq R-19 insulation. Insulation must be installed using manufacturer recommendation for permanent alignment with band joist.

Verification:

- The EarthCraft Technical Advisor will confirm compliance during design review and mid-construction inspections.

BE 4.15 Improved ceiling/roof insulation

Criteria: Insulate ceiling of unconditioned attic or roofline of building with higher R-values than minimum EarthCraft requirements. There are three options in this credit. Projects may only take points for one option.

BE 4.15.A. Ceilings (flat and sloped) Climate Zone 1/2/3 \geq R-49; Climate Zone 4/5 \geq R-60 (4 points)

- Insulate ceilings with unconditioned attics with \geq R-49 or \geq R-60 based on climate zone. Refer to BE 4.4 and BE 4.5 for additional information on proper installation of insulation.

BE 4.15.B Continuous exterior insulation above roof decking Climate Zone 1/2/3/4/5 \geq R-30 (4 points)

- Install continuous exterior insulation above roof decking to \geq R-30. Continuous insulation material must be approved for the use in roof insulation applications.

Clarifications:

- Insulated rooflines and vaulted cathedral ceilings are not considered sloped ceilings; sloped ceilings are defined as having unconditioned attic space above.

Verification:

- The EarthCraft Technical Advisor will confirm compliance during design review and mid-construction inspections.

BE 4.16 Insulate with spray foam insulation

Criteria: Insulate exterior walls, floor and/or ceiling with spray foam insulation. There are multiple options available for certification credits. Projects may achieve points for one or all the options.

BE 4.16.1. Exterior band area (2 points)

- Insulate all exterior band areas, with spray foam insulation to fill the entire wall cavity. R-value of insulation must be a minimum R-13.

BE 4.16.2 Exterior walls including band area (3 points)

- Insulate all exterior walls and band areas, with spray foam insulation to fill the entire wall cavity. R-value of insulation must be a minimum R-13.
- Projects achieving this point may not also take points in BE 4.16.1 above.

BE 4.16.3. Floor system over crawlspace or basement (2 points)

- Insulate underside of conditioned floor with spray foam insulation to a minimum of R-19 over enclosed unconditioned spaces (Ex. Basement, crawlspace, garage)
- Floors over ambient areas, such as cantilevers, must be insulated to a minimum R-30.

BE 4.16.4. Roofline/underside of roof decking \geq R-25 (3 points)

- Insulate underside of roof decking with spray foam insulation to a minimum of R-25.
- Insulation coverage must cover 100% of roofline and extend over the top of all exterior walls
- Attic areas may not include any vents to the exterior (Ex. Soffit or gable vents)
- Attic area shall be considered semi-conditioned space and be provided with supplemental conditioning/dehumidification
- If attic is used only for the service of utilities, foam will be separated from the attic space using a suitable ignition barrier covering or coating according to manufacturer's specifications
- If attic is used for storage or occupancy, spray foam will be separated from the attic space using a thermal barrier material (e.g., 1/2" gypsum wallboard) as specified by applicable building code and manufacturer specifications

BE 4.16.5. Roofline/underside of roof decking \geq R-30 (4 points)

- Insulate underside of roof decking with spray foam insulation to a minimum of R-25.
- Insulation coverage must cover 100% of roofline and extend over the top of all exterior walls
- Attic areas may not include any vents to the exterior (Ex. Soffit or gable vents)
- Attic area shall be considered semi-conditioned space and be provided with supplemental conditioning/dehumidification
- If attic is used only for the service of utilities, foam will be separated from the attic space using a suitable ignition barrier covering or coating according to manufacturer's specifications
- If attic is used for storage or occupancy, spray foam will be separated from the attic space using a thermal barrier material (e.g., 1/2" gypsum wallboard) as specified by applicable building code and manufacturer specifications

Clarifications

- Spray foam insulation must qualify as a full air barrier product in order to achieve credit(s).

Verification:

- The EarthCraft Technical Advisor will confirm compliance during mid-construction and final site inspections

BE 4.17 Exterior wall cavity insulation \geq R-15 (2 points)

Criteria: Install exterior wall insulation that is \geq R-15

Clarifications:

- Projects achieving points in BE 4.14 may not also achieve points with this credit.

Verification:

- The EarthCraft Technical Advisor will confirm compliance during design review and mid-construction inspections.

BE 4.18 Continuous exterior insulation

There are multiple options available for certification credits. Projects may achieve points for only one option.

BE 4.18. A. R-10 (4 points)

- Install R-10 continuous insulation on all exterior walls. Install sheathing to have no gaps greater than 1/4" and provide complete coverage. Where structural sheathing is required by code, install a structurally rated insulated sheathing or over-sheath using insulated sheathing.

BE 4.17.B. R-15 (5 points)

- Install R-15 continuous insulation on all exterior walls. Install sheathing to have no gaps greater than 1/4" and provide complete coverage. Where structural sheathing is required by code, install a structurally rated insulated sheathing or over-sheath using insulated sheathing.

Additional Information:

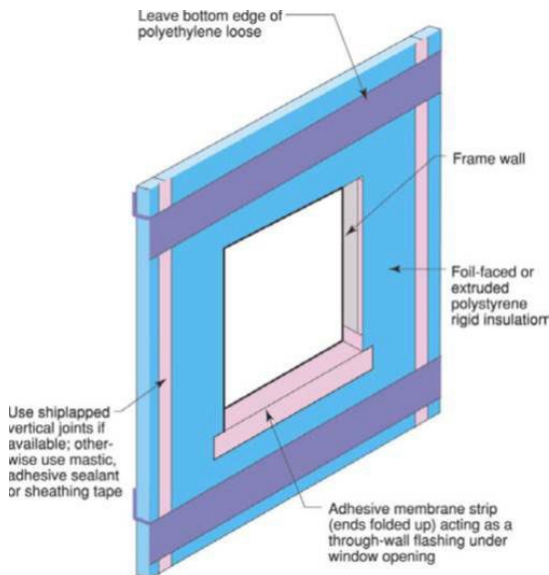

Insulated sheathing methods include rigid foam board that functions as the sheathing and drainage plane (left image) or foam/rigid insulation installed at the exterior of OSB (right image).

Left Image Credit: DOE Building America Solution Center, Continuous Rigid Insulation Sheathing/Siding, <https://bascc.pnnl.gov/resource-guides/continuous-rigid-insulation-sheathingsiding#edit-group-description>

Clarifications

- Insulated siding may not be substituted for insulated wall sheathing without preapproval by EarthCraft.

Verification:

- The EarthCraft Technical Advisor will confirm compliance during design review and mid-construction inspections.

BE 4.19 Insulate basement walls

There are multiple options available for certification credits. Projects may achieve points for only one option.

BE 4.19.A. Frame and insulate basement walls $\geq R-13$ (1 point)

- **Criteria:** Frame and install a minimum R-13 cavity insulation in unfinished basement walls.

BE 4.19.B. Insulate basement walls with continuous insulation $\geq R-5$ (2 points)

- **Criteria:** Insulate below-grade basement walls with R-5 or greater continuous insulation in unfinished basement walls.

Additional Information:

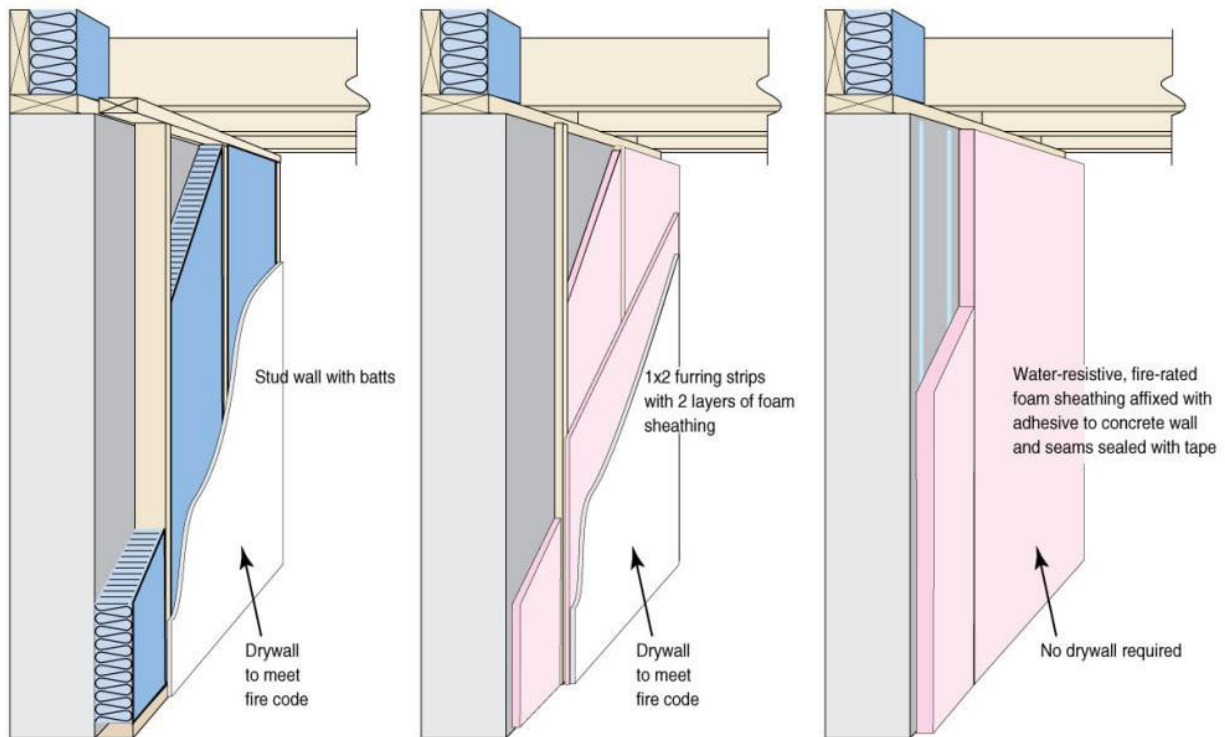

Unfinished basements may be insulated by either framing out the walls and installing $\geq R-13$ cavity insulation or by applying continuous insulation boards (R-5 or R-10 or greater) to the interior of the wall.

Clarifications:

- This credit may only be awarded to projects that choose to insulate unfinished basement areas.
- Projects are not required to install finish materials (drywall, trim).

Verification:

- The EarthCraft Technical Advisor will confirm compliance during design review and mid-construction inspections.

BE 4.20 Attic knee wall insulated \geq R-22 with continuous insulated air barrier on attic side (2 points)

Criteria: Insulate attic knee wall locations with \geq R-22 insulation continuous insulated sheathing at the attic side of the wall.

Additional Information: Refer to BE 4.6 Attic Knee Wall(s) for details on proper insulation installation.

Clarifications:

- Projects that insulate the roofline may not also pursue points in this section.

Verification:

- The EarthCraft Technical Advisor will confirm compliance during final inspections.

BE 5: Windows

Window requirements include minimum efficiency ratings for exterior doors, windows, and skylights installed in residential units and common areas.

BE 5.0 Exterior Door U-factor (requirement)

Criteria: Install energy efficient exterior doors at all residence entrances and at balconies/porches. This is a requirement for all projects.

BE 5.0.1. Opaque door: U-factor ≤ 0.17

BE 5.0.2. Door with $\leq 50\%$ glass: U-factor ≤ 0.25 ; SHGC ≤ 0.25

BE 5.0.3. Door with $\geq 50\%$ glass: U-factor ≤ 0.30 ; SHGC ≤ 0.25

Clarifications:

- The U-factor for doors applies to the whole door assembly, not just the glass portion.

Verification:

- The EarthCraft Technical Advisor will confirm compliance during mid-construction inspections.
- The EarthCraft Technical Advisor will review documentation provided by the project team for compliance with criteria.

BE 5.1 Window U-factor and SHGC (requirement)

Criteria: Install windows that meet minimum EarthCraft efficiency requirements for U-factor and Solar Heat Gain Coefficient (SHGC). This is a requirement for all projects.

BE 5.1.1. U-factor: Climate Zone 1/2 ≤ 0.35 ; Climate Zone 3/4/5 ≤ 0.30

BE 5.1.2. SHGC ≤ 0.25

Verification:

- The EarthCraft Technical Advisor will confirm compliance during mid-construction inspections.
- The EarthCraft Technical Advisor will review documentation provided by the project team for compliance with criteria.

BE 5.2 Skylight U-factors and SHGC (requirement)

Criteria: Install skylights that meet minimum EarthCraft efficiency requirements for U-factor and Solar Heat Gain Coefficient (SHGC). This is a requirement for all projects.

1. U-factor: Climate Zone 2 ≤ 0.65 , Climate Zone 3/4 ≤ 0.55

- **Criteria:** All skylights in Climate Zone 2 must have a U-factor less than or equal to 0.65. All skylights in Climate Zone 3 must have a U-factor less than or equal to 0.55. All skylights in Climate Zone 4 must have a U-factor less than or equal to 0.55.

2. SHGC ≤ 0.25

- **Criteria:** All skylights in Climate Zones 2, 3 and 4 must have a Solar Heat Gain Coefficient (SHGC) less than or equal to 0.25.

Verification:

- The EarthCraft Technical Advisor will confirm compliance during mid-construction inspections.
- The EarthCraft Technical Advisor will review documentation provided by the project team for compliance with criteria.

BE 5.3 NFRC-certified doors, windows, and skylights with label (requirement)

Criteria: Install exterior doors, windows and skylights labeled by the National Fenestration Rating Council (NFRC). This is a requirement for all projects.

Verification:

- The EarthCraft Technical Advisor will confirm compliance during mid-construction inspections.
- The EarthCraft Technical Advisor will review documentation provided by the project team for compliance with criteria.

BE 5.4 Door U-factor

Required for Platinum and Gold certification

Criteria: Install energy efficient exterior doors at all residence entrances and at balconies/porches. There are multiple options available for certification credits. Projects may achieve points for one or all options.

BE 5.4.1. Opaque door: U-factor ≤ 0.12 (1 point)

BE 5.4.2. Door with $\leq 50\%$ glass: U-factor ≤ 0.20 ; SHGC ≤ 0.20 (2 points)

BE 5.4.3. Door with $\geq 50\%$ glass: U-factor ≤ 0.25 ; SHGC ≤ 0.20 (2 points)

Clarifications:

- The U-factor for doors applies to the whole door assembly, not just the glass portion.

Verification:

- The EarthCraft Technical Advisor will confirm compliance during mid-construction inspections.
- The EarthCraft Technical Advisor will review documentation provided by the project team for compliance with criteria.

BE 5.5 Window U-factor and SHGC

Required for Platinum and Gold Certification

Criteria: Install windows that exceed minimum EarthCraft efficiency requirements for U-factor and Solar Heat Gain Coefficient (SHGC). There are multiple options available for certification credits. Projects may achieve points for one or all options.

BE 5.5.1. U-factor: Climate Zone 1/2 ≤ 0.30 ; Climate Zone 3/4/5 ≤ 0.28 (2 points)

BE 5.5.2. SHGC ≤ 0.23 (3 points)

Verification:

- The EarthCraft Technical Advisor will confirm compliance during mid-construction inspections.
- The EarthCraft Technical Advisor will review documentation provided by the project team for compliance with criteria.

BE 5.6 Skylight U-factor and SHGC

Required for Platinum and Gold certification

Criteria: Install skylights that exceed minimum EarthCraft efficiency requirements for U-factor and Solar Heat Gain Coefficient (SHGC). There are multiple options available for certification credits. Projects may achieve points for one or all options.

BE 5.6.1. U-factor: Climate Zone 1/2 ≤ 0.55 , Climate Zone 3/4/5 ≤ 0.53 (2 points)

BE 5.6.2. SHGC ≤ 0.23 (3 points)

Verification:

- The EarthCraft Technical Advisor will confirm compliance during mid-construction inspections.
- The EarthCraft Technical Advisor will review documentation provided by the project team for compliance with criteria.

BE 5.7 ENERGY STAR Door U-factors and SHGC

Criteria: Install ENERGY STAR certified doors that meet the following performance standards for U-factor and SHGC. There are multiple options available for certification credits. Projects may achieve points for one or all options.

BE 5.7.1. Opaque door: U-factor ≤ 0.12 (2 points)

BE 5.7.2. Door with $\leq 50\%$ glass: U-factor ≤ 0.20 ; SHGC ≤ 0.20 (3 points)

BE 5.7.3. Door with $\geq 50\%$ glass: U-factor ≤ 0.25 ; SHGC ≤ 0.20 (3 points)

Verification:

- The EarthCraft Technical Advisor will confirm compliance during mid-construction inspections.
- The EarthCraft Technical Advisor will review documentation provided by the project team for compliance with criteria.

BE 5.8 Window U-factor and SHGC

Criteria: Install windows that exceed minimum EarthCraft efficiency requirements for U-factor and Solar Heat Gain Coefficient (SHGC). There are multiple options available for certification credits. Projects may achieve points for one or all options.

BE 5.8.1. U-factor: ≤ 0.25 (3 points)

BE 5.5.2. SHGC ≤ 0.20 (4 points)

Verification:

- The EarthCraft Technical Advisor will confirm compliance during mid-construction inspections.
- The EarthCraft Technical Advisor will review documentation provided by the project team for compliance with criteria.

BE 5.9 Skylight U-factor and SHGC

Criteria: Install skylights that exceed minimum EarthCraft efficiency requirements for U-factor and Solar Heat Gain Coefficient (SHGC). There are multiple options available for certification credits. Projects may achieve points for one or all options.

BE 5.6.1. U-factor: ≤ 0.50 (3 points)

BE 5.6.2. SHGC ≤ 0.20 (4 points)

Verification:

- The EarthCraft Technical Advisor will confirm compliance during mid-construction inspections.
- The EarthCraft Technical Advisor will review documentation provided by the project team for compliance with criteria.

BE 5.10 Minimum 1.5' overhangs over 80% of south-facing window area (1 point)

Criteria: Design roof and/or window shelves that provide a minimum of 1.5-foot overhangs on 80% of all south-facing window area to minimize summer solar gain.

Additional Information:

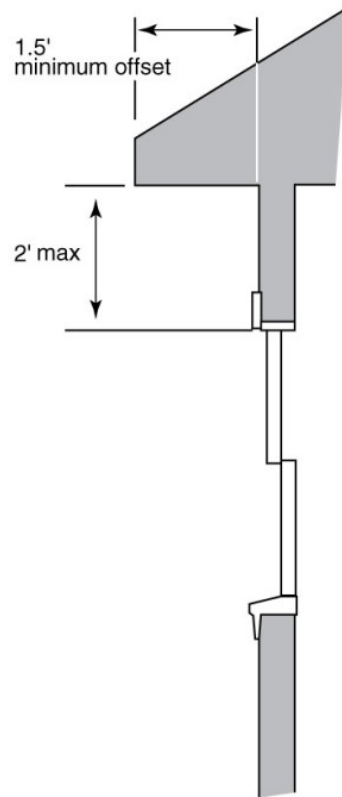

Roof overhang or solar shelves for solar shading should be a minimum of 1.5-feet that is designed and constructed/installed a minimum of 2 feet above the top of the window.

Clarifications

- Installed gutters may not be included in the 1.5' distance.
- Maximum overhang height above window is 2'.

Verification:

- The EarthCraft Technical Advisor will review documentation provided by the project team for compliance with criteria during the design review meeting.
- The EarthCraft Technical Advisor will confirm compliance during mid-construction inspections.

BE 5.11 Solar shade screens

Criteria: Install solar shade screens on the exterior of residential windows. There are two options available for certification credits. Projects may achieve points for one option.

BE 5.12.A. East and West Oriented windows (2 points)

- Install solar shade screens on all eastern and western facing windows with a shading coefficient of ≥ 0.7 . Shade screen must be installed on the exterior of the window.

BE 5.12.B. All windows (3 points)

- Install solar shade screens on all windows with a shading coefficient of ≥ 0.7 . Shade screen must be installed on the exterior of the window.

Additional Information:

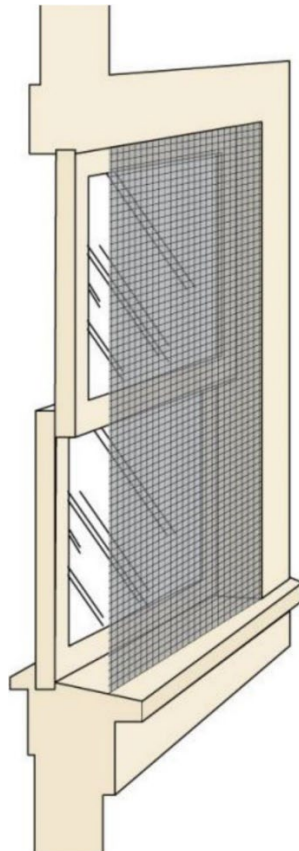

Solar shade screens shall cover the entire glazed area of eastern and western windows.

Verification:

- The EarthCraft Technical Advisor will confirm compliance during final inspections.
- The EarthCraft Technical Advisor will review documentation provided by the project team for compliance with criteria.

BE 6: Roof

Roof systems, not including insulation materials and locations, contribute to energy efficient building designs. Roofing materials that restrict heat transfer into the building or assemblies with thermal mass are strategies that are approved by EarthCraft in the Higher Performance Building Envelope section.

BE 6.0 HVAC ducts in unconditioned attic

Criteria: If HVAC system ductwork is to be installed in an unconditioned attic, select roofing materials to minimize attic heat gain. This is a requirement for projects seeking Gold certification. This credit is not applicable to projects seeking Platinum certification. There are multiple options available for certification credits. Projects may achieve points for only one option.

BE 6.0.A. Attic radiant barrier (2 points)

- **Criteria:** If more than 10 linear feet of ductwork are located in an unconditioned attic, install a radiant barrier with a minimum initial reflectance of 0.90 and maximum initial emittance of 0.10 on all sloped roofs above vented attics.
- Install radiant barrier so that foil is facing down and not in direct contact with any building materials other than roof rafters.
- Any uninsulated attic surfaces must have a radiant barrier installed. This includes sloped roof decks as well as gable end walls.

BE 6.0.B. Cool Roof Rating Council qualified roof ($\geq 75\%$ of total roof area) (2 points)

- **Criteria:** If more than 10 linear feet of ductwork are located in an unconditioned attic, install Cool Roof Rating Council qualified roof product on 75% of total roof area (including attached garages).

Clarifications

- This is not applicable at the Platinum level because at that level all ductwork must be located in conditioned space.

Additional Resources:

- Cool Roof Council Qualified products can be found at: <https://coolroofs.org/directory/roof>

Verification:

- The EarthCraft Technical Advisor will confirm compliance during mid-construction and final inspections.
- The EarthCraft Technical Advisor will review documentation provided by the project team for compliance with criteria during design review meeting.

Energy Efficient Systems

Constructing an energy-efficient building provides a variety of benefits to both the occupants and to the environment. Once the building envelope has been designed, using the unit-as-a-system approach to evaluate heating and cooling systems, ventilation, domestic water heating, lighting and appliances is critical to achieving a high performance building.

An energy efficient project not only saves a resident money on their utility bills but also improves their comfort and health. Comfort is a function of air temperature, relative humidity and radiant heating and cooling, all of which are impacted by the energy systems used in a building. In addition, using less energy reduces the need to extract natural resources, reduces air pollution and eases the strain on our water resources. Buildings account for about 40% of all energy use in the United States. EarthCraft encourages the use of energy efficient systems to reduce this impact.

ES 1: Heating and Cooling Equipment

Heating, Ventilation, Air Conditioning (HVAC) equipment must be designed for the units, residential and commercial, they are intended to serve. This section covers the sizing and selection of HVAC equipment to meet minimum EarthCraft requirements and pointed items.

ES 1.0 Size and select all HVAC equipment with ACCA Manuals J and S (requirement)

Criteria: Size and select all HVAC equipment in accordance with ACCA Manuals J and S. Load calculation must coordinate with accurate construction specifications and plans for the project as well as as-built conditions. This is a requirement for all projects.

ES 1.0.1. Complete load calculation with accredited ACCA Manual J 8th Edition Software or stamp by a Professional Engineer

- **Criteria:** Load calculations must be based on ACCA Manual J 8th Edition Software. The following software programs are compliant with ACCA Manual J 8th Edition:
 - Wrightsoft Right-J8
 - Elite RHVAC
 - Adtek AccuLoads
 - Florida Solar Energy Center's EnergyGauge
 - Carmelsoft HVAC ResLoad-J
 - Avenir MJ8 Editions of HeatCAD and LoopCAD
 - Cool Calc Manual J
 - Alternatively, load calculations may be completed and signed off by a Professional Engineer

ES 1.0.2. Based on worst case unit orientation

- **Criteria:** Load calculation must be based on worst case unit analysis

ES 1.0.3. Use 2021 ASHRAE Handbook of Fundamentals Climate Design Information for outdoor design temperatures

- **Criteria:** Design heating and cooling systems using the annual outdoor design conditions as defined in the 2021 ASHRAE Handbook of Fundamentals, Chapter 14.
 - The 99% design conditions must be used to size heating equipment
 - The 1% design conditions must be used to size cooling equipment.

ES 1.0.4. Indoor temperatures 70°F for heating and 75°F at 50% RH for cooling

- **Criteria:** Design heating and cooling systems using indoor design temperatures of 70°F - 72°F for heating and 75°F and 50% relative humidity (RH) for cooling.
 - Projects may size heating up to 72°F for heating

ES 1.0.5. Base infiltration on "Tight" or "Semi-tight"

- **Criteria:** When using the simplified input method, select "Tight" or "Semi-tight" for software equivalent for whole unit infiltration.
 - Projects may elect to base infiltration on target air leakage thresholds as stated in section BE 3: Blower Door Test

ES 1.0.6. Use actual area, U-factor and SHGC for windows and doors, actual area and R-values of floors, walls, and ceilings

- **Criteria:** Load calculations for each unit type must be based on actual window, insulation and door specifications as installed. Window, door, wall, floor and ceiling areas must be $\pm 10\%$ of actual areas as constructed.

ES 1.0.7. Base on ASHRAE 62.2-2010 Whole-Building ventilation loads

- **Criteria:** Load calculation must be based on ventilation system designed and installed to meet ASHRAE 62.2-2010 whole building ventilation loads. This includes the ventilation system type, location, design rate, and frequency and duration of each ventilation cycle.
 - Exhaust-only whole building ventilation is allowed under the ASHRAE 62.2 standard; however, it is not allowed in the EarthCraft program. Projects in hot, humid areas are advised against installing this ventilation strategy due to the high risk of humidity in residences post-occupancy. Because of this risk, EarthCraft will not accept ventilation plans that include exhaust systems as the sole provider of whole building ventilation.

ES 1.0.8. Select cooling and heating equipment using ANSI/ACCA Manual S, 3rd Edition

- **Criteria:** Use Manual S to select cooling and heating equipment based on the loads calculated based on ACCA Manual J and sized according to system type.

ES 1.0.9 Provide OEM data for each unique system type

- **Criteria:** Original Equipment Manufacturer data must be included in addition to AHRI system verification.

Clarifications

- The abridged edition of ACCA Manual J is not an acceptable methodology within the EarthCraft program.
- Multispeed or multistage equipment may have OEM nominal size increments of one ton. The use of multispeed or multistage equipment can provide extra flexibility to meet the equipment sizing requirements. The equipment oversizing limit should be based on the largest capacity of the unit.
- The floor area must equal the confirmed conditioned floor area as calculated by the EarthCraft Technical Advisor.
- For Air Conditioning Contractors of America, see www.acca.org.

Verification:

- The project team must submit the HVAC load calculations for review prior to the Design Review meeting and/or prior to the purchase of HVAC equipment.
- The EarthCraft Technical Advisor will confirm compliance during mid-construction and final inspections.
- The EarthCraft Technical Advisor will review documentation provided by the project team for compliance with criteria during the design review meeting.
- Load calculation must be stamped by a Professional Engineer along with a signed "Professional Engineer Load Calculation Affidavit."

ES 1.1 If programmable thermostat installed for heat pump, include adaptive recovery technology (requirement)

Criteria: Provide each HVAC system with a programmable thermostat.

Clarifications:

- If a heat pump is installed and a programmable thermostat is used the thermostat must be equipped with adaptive recovery technology. Adaptive recovery prevents the system from relying on strip heat to quickly raise temperatures, also resulting in increased energy use.
- In reference to the 2015 International Energy Conservation Code, "The thermostat controlling the primary heating or cooling system of the dwelling unit shall be capable of controlling the heating and cooling system on a daily schedule to maintain different temperature set points at different times of the day. This thermostat shall include the capability to set back or temporarily operate the system to maintain zone temperatures down to 55°F (13°C) or up to 85°F (29°C). The thermostat shall initially be programmed by the manufacturer with a heating temperature set point no higher than 70°F (21°C) and a cooling temperature set point no lower than 78°F (26°C)."

Verification:

- The EarthCraft Technical Advisor will confirm compliance during final inspections.
- The EarthCraft Technical Advisor will review documentation provided by the project team for compliance with criteria during the design review meeting.

- Instructions on how to schedule the thermostat must be provided to all residents on lease-up and included in the EarthCraft Operations Manual.
- Manual J and S reports must be uploaded for EarthCraft review prior to the approval of mid-construction submission.

ES 1.2 AHRI performance match all indoor/outdoor coils (requirement)

Criteria: Indoor and outdoor coils must be matched in accordance with Air-Conditioning, Heating and Refrigeration Institute (AHRI) standards.

Additional Resources

- The AHRI registry may be found at: www.ahridirectory.org

Verification:

- The EarthCraft Technical Advisor will confirm compliance during final inspections.
- AHRI report(s) must be uploaded for EarthCraft review prior to the approval of mid-construction submission.

ES 1.3 Non-CFC and non-HCFC refrigerant (requirement)

Criteria: Install cooling equipment that contains non-chlorofluorocarbon (CFC) or non-hydrochlorofluorocarbon (HCFC) refrigerant (e.g., R410a).

Exemptions

- Projects not using any refrigerants automatically meet intent provided they demonstrate alternative cooling strategies appropriate for a mixed-humid climate.

Verification:

- The EarthCraft Technical Advisor will confirm compliance during final inspections.
- The EarthCraft Technical Advisor will review documentation provided by the project team for compliance with criteria.

ES 1.4 No electric resistance heat as primary heat source or reheat (requirement)

Criteria: Electric resistance heaters, such as an electric furnace, electric radiant or a baseboard heater, may not be used as the primary heat source for any portion of the conditioned space or used in a reheat design.

Verification:

- The EarthCraft Technical Advisor will confirm compliance during final inspections.

ES 1.5 Heat pump efficiency ≥ 8.8 HSPF/ ≥ 7.5 HSPF2 or equivalent COP (requirement)

Criteria: Heat pumps must have an efficiency of ≥ 8.8 Heating Seasonal Performance Factor (HSPF) or ≥ 7.5 HSPF2, or equivalent Coefficient of Performance (COP).

Verification:

- The EarthCraft Technical Advisor will confirm compliance during final inspections.

ES 1.6 Furnace efficiency $\geq 90\%$ AFUE (requirement)

Criteria: Furnaces must be rated at $\geq 90\%$ Annual Fuel Utilization Efficiency (AFUE). All gas HVAC systems must be sealed combustion, with their combustion air provided from the outdoors.

Verification:

- The EarthCraft Technical Advisor will confirm compliance during final inspections.

ES 1.7 Cooling equipment ≥ 15 SEER/ ≥ 14.3 SEER2 or 12 EER (requirement)

Criteria: Cooling equipment must surpass 14 SEER or 11 EER ratings.

Verification:

- The EarthCraft Technical Advisor will confirm compliance during final inspections.

ES 1.8 Filters are \geq MERV 8

Criteria: Install an HVAC filter with a MERV 8 or higher filtration (according to ASHRAE 52.2) on all HVAC systems. HVAC design and installation must account for airflow based on filter selection.

Verification:

- The EarthCraft Technical Advisor will visually confirm compliance with criteria during final inspections.

ES 1.9 Complete ENERGY STAR Multifamily National HVAC Design Report (1 point)

Required for Platinum and Gold certification

Criteria: Coordinate with HVAC contractor to complete one ENERGY STAR Multifamily National HVAC Design Report for the residential units.

Additional Resources:

The ENERGY STAR Multifamily National HVAC Design Report may be downloaded from ENERGY STAR's Multifamily program website in the National Program Requirements section (document title is MNFC HVAC Design Report):

- https://www.energystar.gov/partner_resources/residential_new/homes_prog_reqs/multifamily_national_page
- A direct link to the fillable PDF document may be found here: [ENERGY STAR Multifamily HVAC Design Report](#)

Clarifications:

- The HVAC contractor must adequately complete the ENERGY STAR Multifamily National HVAC Design Report. The report requires information regarding ventilation design, heating and cooling system design, heating and cooling system equipment, refrigerant tests, refrigerant calculations, electrical measurements, air-flow tests, air-balancing, system controls and drain pan.
- One report is required for each building in the project and must include information applicable to each unique unit type and the systems installed in common areas.

Verification:

- The EarthCraft Technical Advisor will confirm compliance during final inspections.
- The EarthCraft Technical Advisor will review documentation provided by the project team for compliance with criteria.

ES 1.10 Heating equipment efficiency

Required for Platinum and Gold Certification

Criteria: Purchase and install high efficiency heating equipment. There are multiple credits available. Projects may only select one option.

ES 1.10.A Furnace(s) $\geq 95\%$ AFUE (2 points)

- **Criteria:** All heating equipment shall be $\geq 95\%$ Annual Fuel Utilization Efficiency (AFUE) for gas combustion furnaces. All furnaces must be sized within 40% of the heating load as determined by the load calculation.

ES 1.10.B Heat pump(s) Climate Zone 2/3/4 ≥ 9 HSPF/ ≥ 7.65 HSPF2 (2 points)

- **Criteria:** All heating equipment shall be ≥ 9 Heating Seasonal Performance Factor (HSPF) or ≥ 7.65 HSPF2 for heat pumps in Climate Zones 2, 3, and 4.

Verification:

- The EarthCraft Technical Advisor will confirm compliance during final inspections.
- The EarthCraft Technical Advisor will review documentation provided by the project team for compliance with criteria.

ES 1.11 Verification of proper refrigerant charge (1 point)

Required for Platinum and Gold certification

Criteria: Perform refrigerant charge test to ensure appropriate charge for HVAC equipment, with an acceptable subcooling deviation $\pm 3^\circ\text{F}$ or superheat deviation $\pm 5^\circ\text{F}$.

Additional Information:

- Document test results on EarthCraft Refrigerant Charge Test Sheet or ENERGY STAR HVAC Quality Contractor Installation Checklist.
- ANSI/ACCA Standard 5 QI-2010 may be found here:
https://www.energystar.gov/ia/home_improvement/home_contractors/qispec.pdf

Clarifications:

- This credit may be met by following the test methods acceptable to ACCA 5 QI-2010
 - Superheat measurement within $\pm 5^\circ\text{F}$ of the manufacturer's recommended charge
 - Subcooling measurement within $\pm 3^\circ\text{F}$ of the manufacturer's recommended charge
- Geothermal heat pumps, mini-split heat pumps and hermetically sealed factory-charged stems may not be appropriate for standard subcooling or superheat refrigerant charge testing. To accommodate these system types, an OEM (original equipment manufacturer) test procedure may be used and documented.

ES 1.12 Cooling equipment ≥ 16 SEER/ ≥ 15.2 SEER2 (2 points)

Required for Platinum and Gold Certification

Criteria: Install high efficiency cooling equipment with an efficiency of ≥ 16 Season Energy Efficiency Ratio (SEER) or ≥ 15.2 SEER2.

Verification:

- The EarthCraft Technical Advisor will confirm compliance during final inspections.
- The EarthCraft Technical Advisor will review documentation provided by the project team for compliance with criteria.

ES 1.13 Condenser units are spaced 2 feet apart (2 points)

Criteria: Condenser units must be spaced at least two (2) feet apart to reduce restriction of airflow across the condensing coil.

Verification:

- The EarthCraft Technical Advisor will confirm compliance during mid-construction and final inspections.

ES 1.14 Variable speed blower (2 points)

Criteria: Select HVAC equipment with a variable speed air handler blower.

Additional Information:

- Further information on the benefits of variable speed motors may be found at:
 - <https://www.energy.gov/eere/iedo/variable-speed-low-cost-motor-residential-hvac-systems>
 - <https://www.pvhvac.com/blog/variable-speed-compressor-vs-variable-speed-blower/>

Clarifications:

- Projects may achieve points in this section in with the points for higher efficiency ratings.

Verification:

- The EarthCraft Technical Advisor will confirm compliance during design review phase and through verification of HVAC equipment specification documentation and AHRI.

ES 1.15 Dual stage compressor (2 points)

Criteria: Select HVAC equipment with dual stage (2 stage) compressors.

Additional Information:

- Further information on the benefits of dual stage compressors may be found at:
 - <https://www.carrier.com/residential/en/us/homeowner-resources/hvac-basics/2-stage-hvac-system/>
 - <https://www.pvhvac.com/blog/heres-the-lowdown-on-single-stage-two-stage-and-variable-speed-air-conditioning/>

Clarifications:

- Projects may achieve points in this section in with the points for higher efficiency ratings.

Verification:

- The EarthCraft Technical Advisor will confirm compliance during design review phase and through verification of HVAC equipment specification documentation and AHRI.

ES 1.16 Zone control

Criteria: In residential units that would otherwise require more than one heating and cooling system, install one zoned system capable of meeting the heating and cool loads for the entire space. There are multiple options available for certification credits. Projects may achieve points for only one option.

ES 1.16.A. Zoned system with mechanical supply dampers (1 point)

- Install wired damper controls on zoned supply ductwork and thermostats that allow one HVAC system to serve multiple zones.

ES 1.16.B. Zoned system with zoned returns or transfer grills between zones (2 points)

- Install wired damper controls on zoned supply ductwork and thermostats that allow one HVAC system to serve multiple zones and install wired damper controls on each zoned return or install transfer grills between zones to prevent pressure imbalances between separate conditioned areas.

Verification:

- The EarthCraft Technical Advisor will confirm compliance during mid-construction and final inspections.

ES 1.17 Heat pump efficiency >9.0 HSPF/>7.65 HSPF2 (2 points)

Criteria: Purchase and install heat pump efficiency that is greater than 9 HSPF or equivalent HSPF2 for all residential units.

Verification:

- The EarthCraft Technical Advisor will confirm compliance during final inspections.
- The EarthCraft Technical Advisor will review documentation provided by the project team for compliance with criteria.

ES 1.18 ENERGY STAR cooling equipment ≥17 SEER2 (3 points)

Criteria: Install ENERGY STAR qualified cooling equipment that is rated at a ≥17 SEER2 for central air conditioners or air source heat pumps.

Additional Information:

- The ENERGY STAR requirements for cooling equipment may be found at:
https://www.energystar.gov/products/heating_cooling/heat_pumps_air_source/key_product_criteria

Clarifications

- As products and qualifications are periodically updated, the product must be on the list of qualified products at the time it was purchased.

Verification:

- The EarthCraft Technical Advisor will confirm compliance during mid-construction and final inspections.

ES 1.19 ENERGY STAR Qualified Heating Equipment

Criteria: Install ENERGY STAR qualified high efficiency heating equipment. There are multiple credits available. Projects may only achieve points for one option.

ES 1.19.A. ENERGY STAR qualified furnace(s) \geq 95% AFUE (3 points)

- **Criteria:** Install gas furnaces rated at \geq 95% AFUE.

ES 1.19.B. ENERGY STAR qualified heat pump \geq 9 HSPF/ \geq 7.65 HSPF2 (3 points)

- **Criteria:** Install heat pump equipment rated at \geq 9 HSPF/ \geq 7.65 HSPF2

Additional Resources:

- The ENERGY STAR requirements for furnaces, including the ENERGY STAR classifications of US South and US North, may be found at:
https://www.energystar.gov/products/heating_cooling/furnaces/key_product_criteria
- The ENERGY STAR requirements for heat pump equipment may be found at:
https://www.energystar.gov/products/heating_cooling/heat_pumps_air_source/key_product_criteria

Clarifications:

- As products and qualifications are periodically updated, the product must be on the list of qualified products at the time it was purchased.

Verification:

- The EarthCraft Technical Advisor will confirm compliance during mid-construction and final inspections.

ES 1.20 Complete ENERGY STAR Multifamily National HVAC Design Supplement – Common Spaces and Central Systems (1 point)

Criteria: Coordinate with HVAC contractor to complete one ENERGY STAR Multifamily National HVAC Design Report for the common spaces and/or central systems.

Additional Resources:

The ENERGY STAR Multifamily National HVAC Design Supplement may be downloaded from ENERGY STAR's Multifamily program website in the National Program Requirements section (document title is MNFC HVAC Design Report):

- https://www.energystar.gov/partner_resources/residential_new/homes_prog_reqs/multifamily_national_page
- A direct link to the fillable PDF document may be found here: [ENERGY STAR Multifamily HVAC Design Supplement](#)

Clarifications:

- The HVAC contractor must adequately complete the ENERGY STAR Multifamily National HVAC Design Supplement. The report requires information regarding ventilation design, heating and cooling system design, heating and cooling system equipment, refrigerant tests, refrigerant calculations, electrical measurements, air-flow tests, air- balancing, system controls and drain pan.
- One report is required for each building in the project and must include information applicable to each unique unit type and the systems installed in common areas.

Verification:

- The EarthCraft Technical Advisor will confirm compliance during final inspections.
- The EarthCraft Technical Advisor will review documentation provided by the project team for compliance with criteria.

ES 1.21 Cooling equipment and/or cooling mode of heat pump equipment sizing

Criteria: Select cooling equipment sized within specified capacity ranges based on the Manual J loads calculated for each residential unit. There are multiple options available for certification credits. Projects may achieve points for only one option.

ES 1.21.A. Single-Speed Equipment: 90%-115% (1 point)

ES 1.21.B Two-Speed Equipment: 90%-120% (1 point)

ES 1.21.C. Variable-Speed Equipment: 90%-125% (1 point)

Additional Information:

- Refer to ACCA Manual S for additional information on equipment selection best practices
 - <https://www.acca.org/standards/technical-manuals/manual-s>

Verification:

- The EarthCraft Technical Advisor will confirm compliance during HVAC selection as part of the design review phase.
- The EarthCraft Technical Advisor will confirm equipment specified has been installed during final inspections.

ES 2: Ductwork/Air Handler

This section covers proper installation and air sealing of HVAC ductwork and the treatment of HVAC equipment during construction activities. Effective air sealing and design of ductwork ensures that HVAC systems meet their intended design, both in the delivery of conditioned air to the residences and the efficiency the equipment was manufactured to perform at.

ES 2.0 Seal air handlers and duct systems with mastic products (requirement)

Criteria: Seal all seams, joints and connections in forced-air delivery systems using mastic paste or Butyl rubber-backed foil tape (mastic tape). This is a requirement for all projects using ducted HVAC systems. Items to seal include but are not limited to:

- Supply and return ducts
- Supply and return plenums
- Duct-to-plenum connection
- Y-splits, butt joints and boot connections
- Outdoor air intakes
- Air handler condensate and refrigerant line, wire penetrations and unused holes in the air handler cabinet

Additional Information:

Proper air sealing techniques include:

- Using a duct tie and mastic paste or Butyl rubber backed foil tape (mastic tape), connect flex duct liner to sleeve.
- Wrap mastic tape at least two times around duct seam touching at least 1.5" of duct inner liner and metal collar or sleeve.
- Coat duct seams and connections with layer of mastic paste covering seams by 1.5" on both sides and as thick as a nickel.

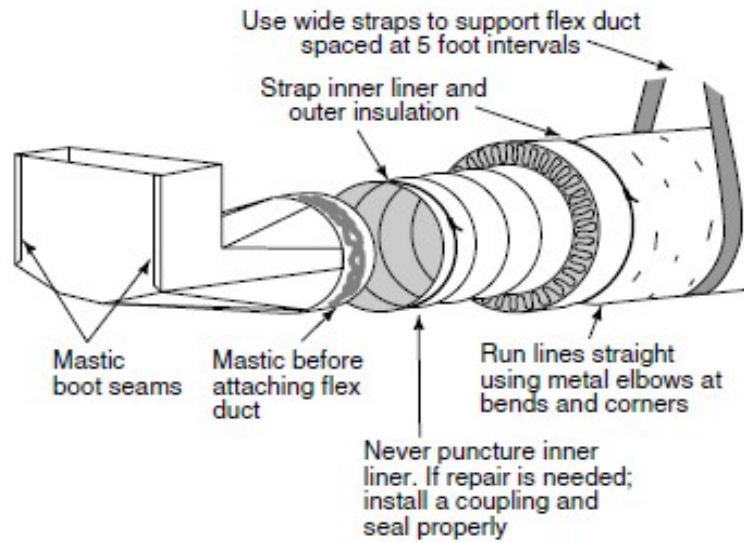

Flexible ductwork (supply and return) should be sealed at the liner to all boots, wyes, and connections using mastic paste or mastic-backed tape. Flexible ductwork should also be installed as straight and short as possible and be supported properly to prevent sagging.

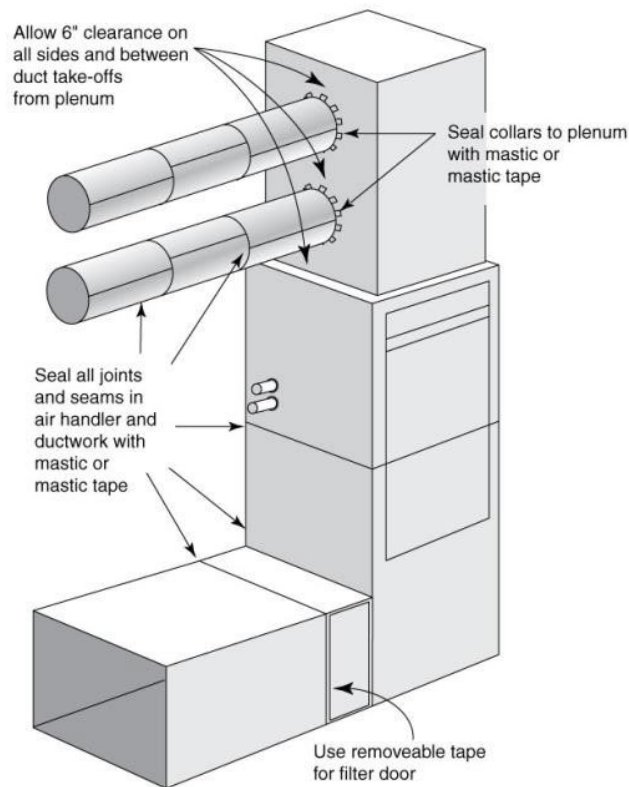

Air seal all joints and penetrations in the air handler and plenums using mastic paste and/or mastic-backed tape.

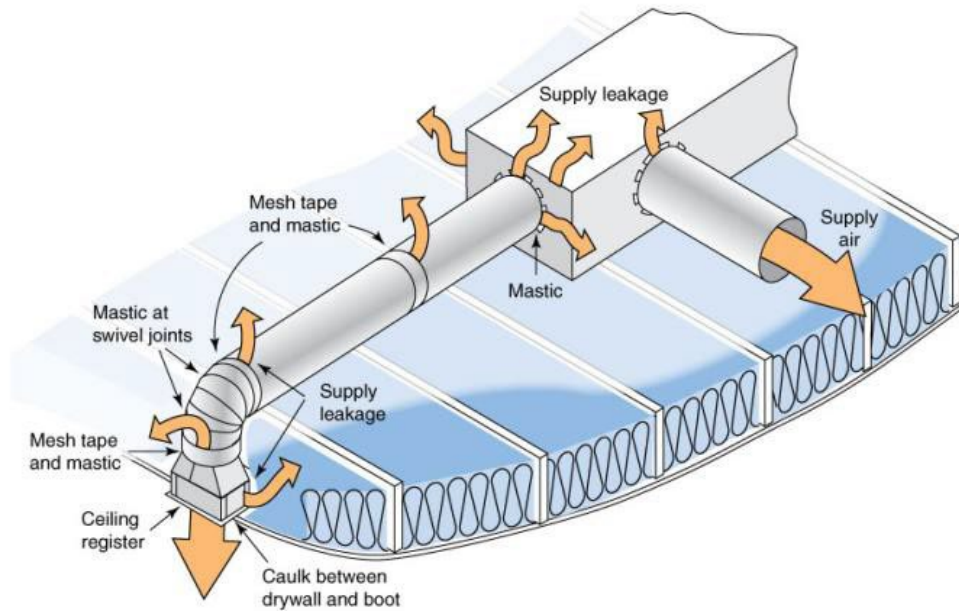

Supply (and return) ductwork should be sealed at the plenum connections, all wyes, and at the boot/register connections.

Clarifications

- Duct tape is not a suitable sealant for ducts. Foil tape may be used only for sealing leaks at the air handler's removable access panels and at filter access panels.
- Caulk, foam, mastic tape or mastic paste may be used to seal duct boots to floor, wall, or ceiling.

Verification:

- The EarthCraft Technical Advisor will confirm compliance during mid-construction and final inspections.

ES 2.1 Code-approved solid connector for all flex-to-flex connections (requirement)

Criteria: Connect all flex-to-flex duct connections together using code-approved rigid connectors or sleeves. This is a requirement for all projects using ducted HVAC systems.

Additional Information:

- Using a duct tie and mastic paste or Butyl rubber backed foil tape (mastic tape), connect flex duct liner to sleeve.
- Wrap mastic tape at least two times around duct seam touching at least 1.5" of duct inner liner and metal collar or sleeve.
- Coat duct seams and connections with layer of mastic paste covering seams by 1.5" on both sides and as thick as a nickel.

Verification:

- The EarthCraft Technical Advisor will confirm compliance during mid-construction and final inspections.

ES 2.2 Fully duct all supply, return, and transfer ductwork (requirement)

Criteria: Install code-approved ductwork for all supply, return and transfer grill systems. This is a requirement for all projects, as applicable to HVAC system design.

Clarifications

Do not use building cavities as a supply return or transfer ducts (e.g., panned joists and stud cavities are not allowed as supply or return ducts). Supplies located in toe-kicks must be fully ducted and sealed to the exterior face of the toe-kick.

Verification:

- The EarthCraft Technical Advisor will confirm compliance during mid-construction and final inspections.

ES 2.3 Duct insulation (requirement)

Criteria: Insulate HVAC system ductwork for all ducted systems. This is a requirement for all projects using ducted HVAC systems.

ES 2.3.1. R-8: Unconditioned attics and exterior

- **Criteria:** Insulate all ducts and all duct connections in unconditioned attics and exterior locations using R-8 insulation or greater.

ES 2.3.2. R-6: All other unconditioned spaces and all conditioned spaces

- **Criteria:** All other ducts in unconditioned and conditioned places must be insulated to R-6.

Clarifications

Ducts left completely exposed inside conditioned space (e.g., modern loft-style duct systems) are not required to be insulated but must be 90% visible at final inspection.

Verification:

- The EarthCraft Technical Advisor will confirm compliance during mid-construction and final inspections.

ES 2.4 No ducts in exterior walls or vaulted ceilings and no plenum within 2' of roofline (requirement)

Criteria: Design and install duct layout such that no ducts are located in exterior walls or insulated vaulted ceilings. This includes insulated walls between conditioned and unconditioned space. This is a requirement for all projects using ducted HVAC systems.

Clarifications

Ducts in exterior walls may be installed if a minimum of R-6 continuous insulation (in addition to the required duct and wall insulation) is provided on the exterior side of the cavity with an interior and exterior air barrier, and the wall cavity is large enough to accommodate the full duct diameter with no crimps.

Verification:

- The EarthCraft Technical Advisor will confirm compliance during mid-construction and final inspections.

ES 2.5 Locate air handler within conditioned space (requirement)

Criteria: Locate all air handlers within conditioned space. This is a requirement for all projects.

Clarifications:

- Projects that install insulation along the underside of roof decking or install continuous exterior insulation above the roof decking and complete all necessary air sealing measures may consider the framed attic areas between the roof and ceiling of residences conditioned space.

Verification:

- The EarthCraft Technical Advisor will confirm compliance during mid-construction and final inspections.

ES 2.6 Minimize pressure imbalance ≤ 6 pa (requirement)

Criteria: Reduce pressure imbalance between bedrooms and area of central return (living room) through various methods, including appropriate duct sizing, door undercuts, dedicated return ducts, jumper ducts, and/or transfer grilles. This is required for projects using a ducted HVAC system with one central return.

Additional Information:

- Measured Pressure imbalance must achieve ≤ 6 pa between bedrooms and central return.

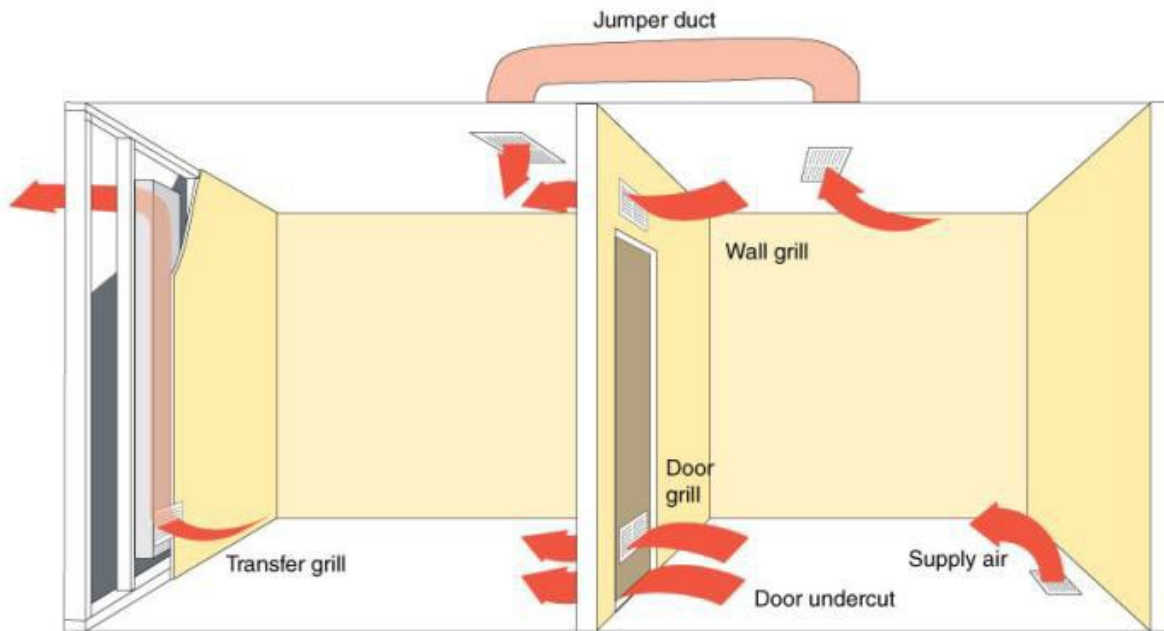

Examples of methods to provide passive air balancing include transfer grilles (in interior walls), jumper ducts (in ceilings) and/or at interior doors.

Verification:

- The EarthCraft Technical Advisor will confirm compliance during mid-construction and final inspections.

ES 2.7 Indoor coil protected until interior finishes complete (requirement)

Criteria: Protect and cover indoor coil until finished floor is installed to reduce particulate matter and pollutants from entering the HVAC system. This is a requirement for all projects.

Additional Information:

- Coverings may be any solid material that is able to maintain a complete covering over the HVAC registers during construction activities. This may include materials such as OSB or Hardee board for floor registers and HVAC tape for registers in ceilings.
- HVAC air handler returns may be protected with temporary MERV 6 filters. These filters must be monitored during construction and periodically replaced. All temporary filters must be replaced with final filters during final inspections so that the Technical Advisor may be able to verify the final MERV rating of the filters.

Verification:

- The EarthCraft Technical Advisor will confirm compliance during mid-construction and final inspections.

ES 2.8 No new duct take-offs within 6" of supply plenum/supply trunk cap (requirement)

Criteria: To improve airflow efficiency to all rooms no duct take-offs may be installed within 6" of supply plenum cap or supply trunk line and no ducts may be installed at the end cap of the supply plenum or supply trunk line. This is a requirement for all ducted HVAC systems.

Verification:

- The EarthCraft Technical Advisor will confirm compliance during mid-construction and final inspections.

ES 2.9 Two-piece HVAC boot sealed at mechanical connection (requirement)

Criteria: Where two-piece/two-part HVAC boots are installed, add mastic at the connection to ensure the boot does not pull away from the mechanical connection mounted in the ceiling.

Verification:

- The EarthCraft Technical Advisor will confirm compliance during mid-construction and final inspections.

ES 2.10 Minimize pressure imbalance within units ≤ 3 pa (3 points)

Required for Platinum and Gold certification

Criteria: Reduce pressure imbalance between bedrooms and area of central return (living room) through various methods, including appropriate duct sizing, door undercuts, dedicated return ducts, jumper ducts, or transfer grills.

Additional Information:

- Measured Pressure imbalance must achieve ≤ 3 pa between bedrooms and central return.
- Refer to ES 2.6 for additional information about pressure balancing measures.

Verification:

- The EarthCraft Technical Advisor will confirm compliance during mid-construction and final inspections.

ES 2.11 Fully duct all return(s) (5 points)

Required for Platinum certification

Criteria: Design HVAC systems for all residential units with fully ducted returns. Return ductwork must be approved HVAC duct material, including metal, flexible duct, and/or duct board. Systems may be designed with a single, central return or with multiple ducted returns to each bedroom.

Additional Information:

- Measured Pressure imbalance must achieve ≤ 3 pa between bedrooms and central return.
- Refer to ES 2.6 for additional information about pressure balancing measures.

Verification:

- The EarthCraft Technical Advisor will confirm compliance during design review phase, mid-construction and final inspections.

ES 2.12 Install rigid duct work or pull all flex ducts with no pinches and properly support at intervals $\leq 4'$ (2 points)

Criteria: Construct all duct work using rigid duct materials (sheet metal or duct board) or ensure all flex ducts are pulled tight and, to allow for optimal airflow, that inner liner is not constricted.

- Bends in flex ducts must have a radius of at least the diameter of the duct or more.
- Use balancing dampers instead of loops to limit flow to diffusers and use baffles for acoustical control.
- Support flexible ducts at intervals recommended by the manufacturers but at least every 4 feet.
- Use bands that are at least 1 1/2" wide, with no more than 2" sag between supports and located above ceiling insulation to prevent condensation.

Additional Information:

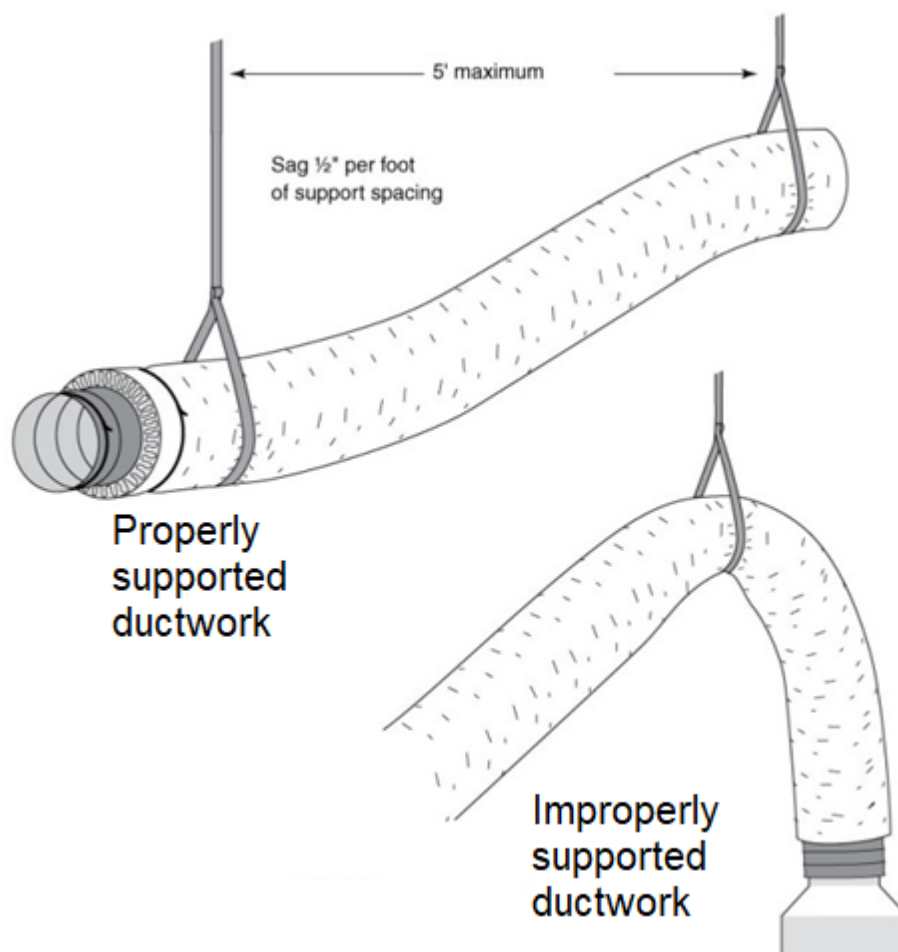

Properly support ductwork, particularly flexible ductwork, with $\geq 1"$ strapping a minimum of every 5'. Install ductwork to minimize bends and to reduce bends that are 90° or tighter. When installing flexible ductwork, pull liner tightly to reduce pinches and sagging between strappings.

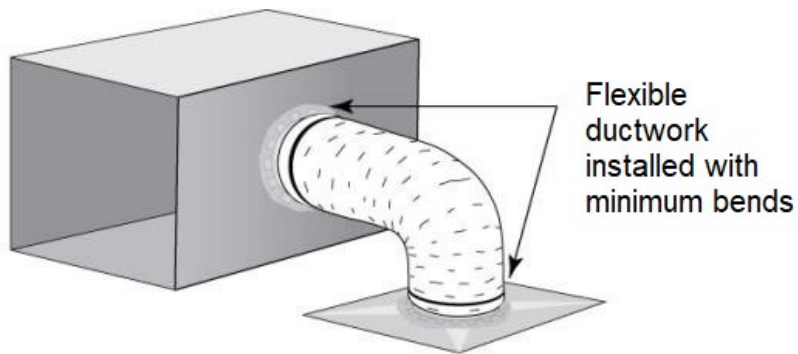

Correct: flex duct installed with enough material, to create smooth turns with proper angles

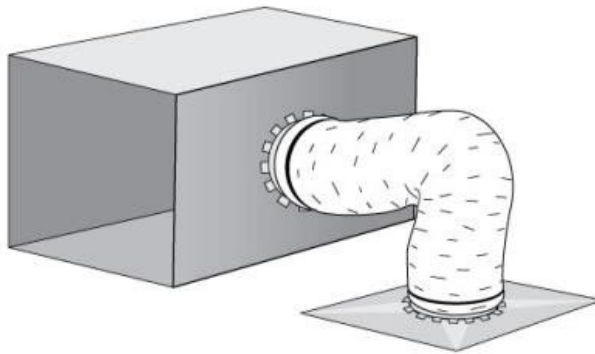

Incorrect: flex duct installed with extra material, creating bunched turns with pinched angles

Install ductwork with minimal bends and elbows. Whenever possible, install ductwork with bends that are 45° or use mechanical elbows to minimize friction of air movement.

Clarifications

- Do not install ducts in contact with roof decking.
- Do not install flex ducts located in unconditioned spaces in cavities smaller than the outer duct diameter or flex ducts located in conditioned spaces in cavities smaller than the inner duct diameter.

Verification:

- The EarthCraft Technical Advisor will confirm compliance during mid-construction and final inspections.

ES 2.13 Verify supply and return duct static pressure (2 points)

Required for Platinum and Gold certification

Criteria: Verify that supply and return duct static pressure is within manufacturer and design specifications for capacity needed to meet the calculated loads.

Clarifications:

- Pressure must be measured in the ducts and not in the air handler itself.
- HVAC contractor test-hole locations must be well marked and easily accessible for verification. Supply and return duct static pressure measurements in inches of water column (IWC) must be submitted to builder by HVAC contractor.
- Verification of static pressure using the same test holes must confirm results are <110% of contractor values.

Verification:

- The project team shall submit documentation demonstrating compliance with criteria to the EarthCraft Technical Advisor at the beginning of final inspections.
- The EarthCraft Technical Advisor may diagnostically test for compliance with criteria during final inspections.

ES 2.14 Measure and balance airflow for each duct run $\pm 20\%$ of design (3 points)

Criteria: With all interior doors closed, measure and balance airflow for each room using a flow hood, anemometer or RESNET-approved equivalent. Adjust airflow to within the greater of $\pm 20\%$ or 25 cfm of the load calculation room-by-room specifications.

Clarifications

- Ducts shall not include coiled or looped ductwork except to the extent needed for acoustical control.
- Balancing dampers or proper duct sizing shall be used instead of loops to limit flow to diffusers.
- When balancing dampers are used, they shall be located at the trunk to limit noise unless the trunk will not be accessible when the balancing process is conducted. In such cases, opposable blade dampers or dampers located in the duct boot are permitted.

Verification:

- The project team shall submit documentation demonstrating compliance with criteria to the EarthCraft Technical Advisor at the beginning of final inspections.
- The EarthCraft Technical Advisor may diagnostically test for compliance with criteria during final inspections.

ES 2.15 Install ducts per ACCA Manual D duct design (3 points)

Criteria: Design and install ductwork in accordance with ACCA Manual D guidelines latest edition. Integrate duct layout with construction documentation to ensure proper installation and provide clash detection. At a minimum, duct layout design must document duct diameter and length, and register location.

Verification:

- The builder must submit documentation demonstrating compliance with criteria to the EarthCraft Technical Advisor prior to the beginning of HVAC rough-in.
- The EarthCraft Technical Advisor will review documentation provided by the builder for compliance with criteria and will visually confirm compliance with criteria during mid-construction inspections.

ES 2.16 Locate all HVAC ductwork within conditioned space (5 points)

Criteria: Locate 100% of all supply and return ductwork within conditioned space.

Additional Information:

- The band areas between floors of multi-level apartment buildings are considered conditioned space when they have been properly air-sealed and insulated meeting the same specifications as exterior walls.
- Top level units may bring HVAC ductwork within conditioned space by either designing fur-down framing in the residential units or by installing insulation along the roofline of the building.

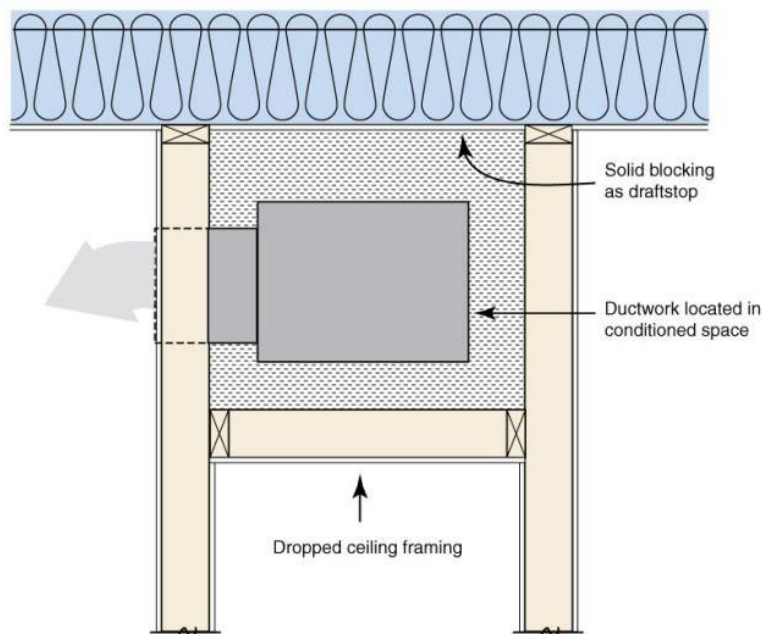

Fur down ceiling framing allows for supply and jumper ductwork to be installed within conditioned space of a building that has a vented, unconditioned attic.

Clarifications:

- Projects using ductless HVAC systems are not eligible for this credit.

Verification:

- The EarthCraft Technical Advisor will confirm compliance during mid-construction and final inspections.

ES 2.17 HVAC system and ductwork is dry and clean (1 point)

Criteria: Inspect ductwork before installing registers, grilles, and diffusers to verify it is dry and substantially free of construction dust (wood, drywall) or debris.

- Inspect air-handling equipment and verify that heat exchangers/coils are free of dust caused by construction activities.
- Replace filter prior to the beginning of final inspections. If necessary, replace filter again prior to unit occupancy.
- After installation of registers, grilles, and diffusers, verify detectable airflow from each supply outlet.

Clarifications

- If duct openings in floors were uncovered during construction, thoroughly vacuum out each opening prior to installing registers, grilles, and diffusers. All ductwork shall be cleared of dust and debris at each supply and/or return register.
- If duct openings in ceilings were uncovered during construction, thoroughly vacuum out each opening and clean off any dust and/or paint residue. All ductwork shall be cleared of dust and debris at each supply and/or return register.

Verification:

- The EarthCraft Technical Advisor will confirm compliance during the final inspections.

ES 2.18 Duct design and installation

Criteria: Install ductwork systems with materials that are designed to improve airflow, system pressure and overall distribution. There are multiple credits available; projects may achieve points for one or all options.

ES 2.18.1. Rigid metal supply trunk line (2 points)

- **Criteria:** Use the “trunk and branch” configuration to design and install all duct systems. The trunk and branch configuration requires that each HVAC system has at least one rigid supply trunk with multiple, short branch take-offs to each supply register.

ES 2.18.2. Space all supply duct take-offs ≥ 6 ” apart (1 point)

- **Criteria:** Space all supply duct take-offs at least 6” apart from each other with no duct take-offs originating from the cap of the supply plenum. Junction boxes with 4 take-offs or less and no take-off(s) directly opposite the main supply to the junction box are excluded.

ES 2.18.3. Install rigid circular duct as supply plenum from air handler (2 points)

- **Criteria:** Install rigid, circular ductwork as the supply plenum to improve ductwork efficiency by reducing the duct leakage commonly found at the plenum board connection to the air handler.

Verification:

- The EarthCraft Technical Advisor will confirm compliance during mid-construction and final inspections.

ES 2.19 Duct insulation in unconditioned spaces $\geq R-10$ (1 point)

Criteria: Insulate all ductwork located outside of conditioned spaces (e.g., in unconditioned attics, vented crawlspaces and exterior locations) to R-10 insulation or greater.

Verification:

- The EarthCraft Technical Advisor will confirm compliance during mid-construction and final inspections.

ES 2.20 Return plenum duct take-off free area is 120% of supply plenum duct take-off free area (2 points)

Criteria: Design return plenum so that the total return plenum area is at least 20% larger than the space available for air to flow through the supply plenum. By providing a larger return plenum the system is at least equal to or larger than the amount of air on the supply side of the system, helping to provide proper system operation.

Verification:

- The EarthCraft Technical Advisor will confirm compliance during design review phase.
- The EarthCraft Technical Advisor will collect design documentation from HVAC contractor or mechanical engineer and verify installation during mid-construction and final inspections.

ES 2.21 Ductless HVAC equipment

Criteria: Install ductless HVAC equipment in residential units. There are two options available for certification credits. Projects may achieve points for one or both options.

ES 2.21.1 All studio style residential units (2 points)

ES 2.21.2 All residential units with 1 or more bedrooms (3 points)

Verification:

- The EarthCraft Technical Advisor will confirm compliance during design review phase.
- The EarthCraft Technical Advisor will installation during mid-construction and final inspections.

ES 3: Duct Leakage Test Results

HVAC duct leakage testing is required for ducted HVAC equipment in residential units. EarthCraft sets minimum leakage requirements for all projects and awards credits for projects that achieve additional levels of air tightness for total leakage and/or leakage to outside tests. Duct leakage results are recorded as a percentage of leakage based on floor area served by the system:

$$\text{Percent duct leakage} = \frac{\text{System HVAC leakage (CFM}_{25}\text{)}}{\text{Square footage served by HVAC system}}$$

ES 3.0 Test duct leakage based on floor area served (requirement)

Criteria: Quantify HVAC ductwork air leakage on ducted systems. HVAC duct leakage testing procedures shall comply with current RESNET standards and leakage testing equipment manufacturer criteria. This is a requirement for projects of all building heights that use ducted HVAC systems.

ES 3.0.1. Leakage to outside ≤6%

- **Criteria:** Duct leakage test result for leakage to outside is ≤3% of floor area served for all tested systems.

ES 3.0.2. Total leakage ≤6% at final

- **Criteria:** Duct leakage test result for total leakage at final is ≤6% of floor area served for all tested systems.

Additional Information:

- Duct leakage is calculated using the standard protocol set forth by ASTM for duct pressurization testing at 25 Pascals.
- Duct leakage to outside is defined as the amount of air that leaves HVAC system ductwork outside of the building envelope and is tested separately from total duct leakage.
- Total duct leakage is defined as the amount of total leakage that leaves the HVAC system, including air handler equipment and all ductwork.

Clarifications:

- Both the leakage to the outside and the total leakage duct tests apply to all HVAC systems, even those fully inside the building envelope.
- When energy modeling is used, floor area must equal conditioned floor area used for the confirmed HERS energy model.

Verification:

- The EarthCraft Technical Advisor will confirm compliance during mid-construction and final inspections.

ES 3.1 Test duct leakage based on floor area served

Criteria: Quantify HVAC duct leakage that is less than the minimum leakage rates required in ES 3.0. HVAC duct leakage testing procedures shall comply with current RESNET standards and leakage testing equipment manufacturer criteria. There are multiple point options available in this credit, projects may choose one or both.

ES 3.1.1. Leakage to outside $\leq 4\%$ (8 points)

- **Criteria:** Duct leakage test result for leakage to outside is $\leq 2\%$ of floor area served for all tested systems.

ES 3.1.2. Total leakage $\leq 4\%$ (8 points)

- **Criteria:** Duct leakage test result for total leakage is $\leq 5\%$ of floor area served for all tested systems.

Clarifications:

- Both the leakage to the outside and the total leakage duct tests apply to all HVAC systems, even those fully inside the building envelope.
- When energy modeling is used, floor area must equal conditioned floor area used for the confirmed HERS energy model.
- Rough-in test results may not be used to achieve either credit.

Verification:

- The EarthCraft Technical Advisor will confirm compliance during final inspections.

ES 3.2 Test duct leakage based on floor area served: Leakage to Outside $\leq 3\%$ (10 points)

Criteria: Quantify HVAC duct leakage to outside that is $\leq 3\%$. HVAC duct leakage testing procedures shall comply with current RESNET standards and leakage testing equipment manufacturer criteria. There are multiple point options available in this credit.

Clarifications:

- Both the leakage to the outside and the total leakage duct tests apply to all HVAC systems, even those fully inside the building envelope.
- When energy modeling is used, floor area must equal conditioned floor area used for the confirmed HERS energy model.
- Rough-in test results may not be used to achieve either credit.

Verification:

- The EarthCraft Technical Advisor will confirm compliance during final inspections.

ES 4: Ventilation

The ventilation section covers all ventilation system components for the HVAC system, including whole-building ventilation and spot ventilation installed for each residential unit. Ventilation meeting ASHRAE standards is required under the EarthCraft program.

ES 4.0 Design and install a whole-unit ventilation system that is based on ASHRAE 62.2-2010 ventilation airflow requirements (requirement)

Criteria: Install outside air-intake with ventilation cfm, damper and controls meeting ASHRAE 62.2-2010 or ASHRAE 62.1-2010 Whole-Building mechanical ventilation requirements for multifamily buildings. This is a requirement for all projects.

ES 4.0.1. Equipment selected may only be a supply/positive pressure or balanced pressure system

- **Criteria:** Provide a dedicated whole building ventilation system designed to meet the continuous air flow requirements as calculated by ASHRAE 62.2-2010. Whole-building ventilation system selected must be a balanced or supply pressure system. Exhaust-only (negative pressure) strategy for whole-building ventilation is not allowed in residential units.

ES 4.0.2. Include total design ventilation airflow in HVAC load calculations

- **Criteria:** Include whole-building ventilation airflow (CFM) in HVAC load calculations for cooling and heating loads.

ES 4.0.3. System must filter outdoor air with \geq MERV 6 filter

- **Criteria:** ventilation supply airflow must be filtered with \geq MERV 6 filter prior to crossing over HVAC coil when ventilation equipment is integrated with central heating and cooling system.

Additional Information:

- Projects using the ASHRAE 62.2-2010 standard may refer to the Residential Energy Dynamics online calculator: <https://www.redcalc.com/ashrae-62-2-2010/>
- Whole building ventilation system additional information:
 - A supply pressure ventilation system that utilizes the HVAC air handler must have an Electronically Commutated Motor/ Integrally Controlled Motor (ECM/ICM) with a variable speed fan that runs at a reduced speed during ventilation.
 - Design and installed to operate at least once per day and at least 10% of the time (one hour and twenty minutes out of every twelve hours).
 - Intermittent ventilation systems that utilize the HVAC air handler must include a controller to reduce the ventilation run time by accounting for hours when HVAC system is heating or cooling the home.

Clarifications

- Ventilation system must be mechanical.
- Powder rooms (rooms without a bathtub and/or shower) are exempt from this requirement.

Verification:

- Prior to the Design Review Meeting, the design team must submit the heating and cooling system design along with the air handler/ductwork design to the Technical Advisor for review. The ECTA will review the strategy for compliance with EarthCraft Program standards and the approved designs must be included by the design team in the mechanical drawings of the construction set.
- The EarthCraft Technical Advisor will review documentation provided by the builder for compliance with criteria and will visually confirm compliance with criteria at final inspection.
- Provide information on type of system, maintenance, and monitoring requirements in project-specific owner's manual.

ES 4.1 When installed, fresh air intakes must achieve the following standards (requirement)

Criteria: Install fresh air supply ductwork in locations that are separated from known contaminants and/or areas with high risk of contaminant exposure. This is a requirement for all projects.

ES 4.1.1. $\geq 10'$ away from exhaust outlets, vehicle idling zones, parking garages

- **Criteria:** Locate air intakes for all building systems at least 10 feet away from any exhaust outlets, driveways/parking lot, garage entrance, and other areas where vehicle exhaust may be present.
 - Air intake must pull air directly from outdoors and not from adjacent dwelling units, garages, unconditioned crawlspaces, or attics.

ES 4.1.2. When run to the soffit, the duct must be extended and affixed through soffit vent.

- **Criteria:** If running fresh air through the soffit, it must extend and be affixed all the way through the soffit vent and may not terminate and rest on top of the soffit.

ES 4.1.3. Fresh air duct may not be run to the roof

- **Criteria:** Fresh air supply duct must be $\geq 18''$ above roof.

ES 4.1.4. Fresh air shutoff may not be controlled by a humidistat

- **Criteria:** Fresh air controls should be based on a timer to ensure that minimum outdoor air ventilation rates are met within each 24-hour time period.

ES 4.1.5. Install round metal duct material with insulation

- **Criteria:** When ducting the fresh air into a unit, use rigid duct work with insulation that meets at least code minimum based on location of ductwork.

ES. 4.1.6. All intakes must be ducted to the exterior of the building

- **Criteria:** Locate air intakes for all building systems outside of the building shell.

Clarifications

- Air intakes include intakes for sealed combustion equipment, outdoor ventilation air supply, etc., and exhaust outlets include bathroom exhaust fans, range hood exhaust fan outlet, dryer exhaust, combustion exhaust, radon vent, etc.
- Design air-intake locations to minimize obstruction by snow, plantings, condensing units, or other material.
- Ventilation system may use outdoor air monitoring for humidity, temperature, or other indoor air quality contaminants to control quality of outdoor air ventilation within a 24-hour period, but system must still be able to meet daily ventilation requirements.

Verification:

- The EarthCraft Technical Advisor will confirm compliance during mid-construction and final inspections.

ES 4.2 Seal seams of all intake and exhaust ducts with mastic (requirement)

Criteria: Mastic paste must be used on the sealing of all ducts. Coat duct seams and connections with layer of mastic paste covering seams by 1.5" on both sides and as thick as a nickel. This is a requirement for all projects.

Verification:

- The EarthCraft Technical Advisor will confirm compliance during mid-construction and final inspections.

ES 4.3 Install ASHRAE compliant exhaust fans rated at ≥ 50 CFM in all bathrooms and duct to outside (requirement)

- **Criteria:** Vent all bathroom exhaust fans to the outdoors using an ENERGY STAR qualified bath fan rated at ≥ 50 CFM. Bath fans must be vented to the exterior of the building and be fitted with vent terminations that have a damper.
 - Verify bath fan airflow using a testing method allowed by Chapter 8: RESNET Standard for Performance Testing and Work Scope: Enclosure and Air Distribution Leakage Testing. Measured fan CFM must be within 10% of rated air flow.

ES 4.4. Gas kitchen range/or cooktop vented to exterior with ASHRAE compliant ≥ 100 CFM fan (requirement)

- **Criteria:** Where gas range or cooktops are installed, install a kitchen exhaust fan (e.g., kitchen range or downdraft hood) that is rated at ≥ 100 CFM and is vented directly to the outdoors. This is a requirement for all gas ranges, cooktops and/or ovens in residences and common areas.
- Kitchen range/cooktop additional information:
 - To ensure the installed fan exhausts the correct amount of cfm, kitchen exhaust fans must either be rated at a higher airflow than 100 cfm (minimum of 130 cfm on high setting) or have an installed measured airflow verified by a third-party ≥ 100 cfm and within 15% of the design rate.
 - Intentional make-up air must be provided for any kitchen vent fan rated at greater than 150 cfm so that total exhaust flow (makeup airflow minus fan rated exhaust) is no greater than 150 cfm.
 - Kitchen exhaust fans must meet ASHRAE 62.2-2010 section 5 requirements. If exhausting continuously, fan must exhaust greater than 5 ACH, based on kitchen volume; if controlled by occupant to exhaust intermittently, fan must exhaust ≥ 100 cfm.

ES 4.5 Back-draft dampers for kitchen, bathroom, and dryer exhausts (requirement)

Criteria: Install back-draft dampers for all exhaust fans sharing a common exhaust. This is a requirement for all projects.

Clarifications

- Common exhausts may not be shared by fans in separate dwelling units (e.g., townhomes, condominiums, apartment units).

Verification:

- The EarthCraft Technical Advisor will confirm compliance during mid-construction and final inspections

ES 4.6 ENERGY STAR certified bathroom exhaust fans (requirement)

- **Criteria:** Vent all bathroom exhaust fans to the outdoors using an ENERGY STAR qualified bath fan rated at ≥ 50 CFM. Bath fans must be vented to the exterior of the building and be fitted with vent terminations that have a damper.
 - Verify bath fan airflow using a testing method allowed by Chapter 8: RESNET Standard for Performance Testing and Work Scope: Enclosure and Air Distribution Leakage Testing. Measured fan CFM must be within 10% of rated air flow.

ES 4.7 Duct clothes dryers to outside (requirement)

Criteria: All clothes dryers must be ducted to the outside. This is a requirement for all projects.

Clarifications

- For electric condensing dryers, plumb condensate to a drain according to manufacturer instructions.

Verification:

- The EarthCraft Technical Advisor will confirm compliance during mid-construction and final inspections.

ES 4.8 No power roof vents (requirement)

Criteria: No power roof vents installed in the attics

Verification:

- The EarthCraft Technical Advisor will confirm compliance during mid-construction and final inspections.

ES 4.9 ENERGY STAR qualified ceiling fans (1 point)

Required for Platinum and Gold Certification

Criteria: If installed, all ceiling fans must be ENERGY STAR qualified.

Clarifications:

- As products and ENERGY STAR qualifications are periodically updated, the product must be on the list of ENERGY STAR qualified products at the time it was purchased.

Verification:

- The EarthCraft Technical Advisor will confirm compliance during mid-construction and final inspections.
- The builder must submit documentation demonstrating compliance with criteria to the EarthCraft Technical Advisor at the final inspection.

ES 4.10 ENERGY STAR bath fans with field verified, measured airflow ≥ 50 cfm (2 points)

Required for Platinum and Gold certification

Criteria: Field verify bath fans to confirm airflow is ≥ 50 cfm. Bath fans must all be ENERGY STAR certified.

Clarifications:

- As products and ENERGY STAR qualifications are periodically updated, the product must be on the list of ENERGY STAR qualified products at the time it was purchased.
- Projects may only achieve these points if field verification method is to test the airflow of the system. Using the ASHRAE prescriptive ducting table for verification is not eligible for points.

Verification:

- The EarthCraft Technical Advisor will confirm compliance during final inspections.

ES 4.11 Electric kitchen range/or cooktop vented to exterior \geq 100 CFM fan (3 points)

Required for Platinum and Gold certification

Criteria: Where electric range or cooktops are installed, install a kitchen exhaust fan (e.g., kitchen range or downdraft hood) that is rated at \geq 100 CFM and is vented directly to the outdoors.

Additional Information:

- To ensure the installed fan exhausts the correct amount of cfm, kitchen exhaust fans must either be rated at a higher airflow than 100 cfm (minimum of 130 cfm on high setting) or have an installed measured airflow verified by a third-party \geq 100 cfm and within 15% of the design rate.
- Intentional make-up air must be provided for any kitchen vent fan rated at greater than 150 cfm so that total exhaust flow (makeup airflow minus fan rated exhaust) is no greater than 150 cfm.
- Kitchen exhaust fans must meet ASHRAE 62.2-2010 section 5 requirements. If exhausting continuously, fan must exhaust greater than 5 ACH, based on kitchen volume; if controlled by occupant to exhaust intermittently, fan must exhaust \geq 100 cfm.

Verification:

- The EarthCraft Technical Advisor will confirm compliance during mid-construction and final inspections.

ES 4.12 Verify whole building air ventilation airflow within 20% of design values (2 points)

Required for Platinum and Gold certification

Criteria: Measure ventilation rates to be within 100-120% of design rate.

Additional Information:

- Verify fan airflow using a testing method allowed by Chapter 8: RESNET Standard for Performance Testing and Work Scope: Enclosure and Air Distribution Leakage Testing. Confirmation

Verification:

- The EarthCraft Technical Advisor will confirm compliance during final inspections.

ES 4.13 Install and label accessible ventilation controls, with override controls for continuously operating ventilation fans (1 point)

Required for Platinum and Gold certification

Criteria: Provide occupant with accessible, labeled controls for whole building ventilation equipment.

Clarifications

- Labels are not required for ventilation controls that are obvious, such as bathroom exhaust fan(s).
- Include readily accessible override controls for continuously operating ventilation and exhaust fans (e.g., ERVs and other outdoor air supply ventilation systems).
- Controls must be labeled and accessible for residence occupants, not located in locked utility closets.

Verification:

- The EarthCraft Technical Advisor will confirm compliance during final inspections.

ES 4.14 Bathroom exhaust fans rated ≤ 2 sones (1 point)

Required for Platinum and Gold certification

Criteria: Select and install bath fans for residential units that are rated to operate a noise levels no louder than 2 sones

Verification:

- The EarthCraft Technical Advisor will confirm compliance during final inspections.
- The builder must submit documentation demonstrating compliance with criteria to the EarthCraft Technical Advisor at the final inspection.

ES 4.15 Exhaust fan wired with light in bathroom (1 point)

Required for Platinum certification

Criteria: Wire bath fan to the lighting system in the bathroom to encourage proper ventilation. Bath fans that include internal lights are eligible for this point.

Verification:

- The EarthCraft Technical Advisor will confirm compliance during final inspections.

ES 4.16 Replace existing bath fan ductwork with round metal duct material that is insulated $\geq R-6$ (2 points)

Required for Platinum certification

Criteria: Duct all exhaust fans with rigid duct material and seal connections with mastic or mastic tape.

Additional Information:

- Coat duct seams and connections with layer of mastic paste covering seams by 1.5" on both sides and as thick as a nickel.
- Wrap mastic tape at least two times around duct seam touching at least 1.5" of duct inner liner and metal collar or sleeve.

Verification:

- The EarthCraft Technical Advisor will confirm compliance during mid-construction inspections.

ES 4.17 Radon construction

Criteria: Install a passive radon vent system in compliance with the Environmental Protection Agency radon-resistant construction techniques and/or test for radon levels post occupancy. There are two options available for certification credits. Projects may achieve points for one or both options.

ES 4.17.1. Passive, radon/soil gas vent system labeled on each floor (2 points)

ES 4.17.2 Radon test of building prior to occupancy (1 point)

Additional Information:

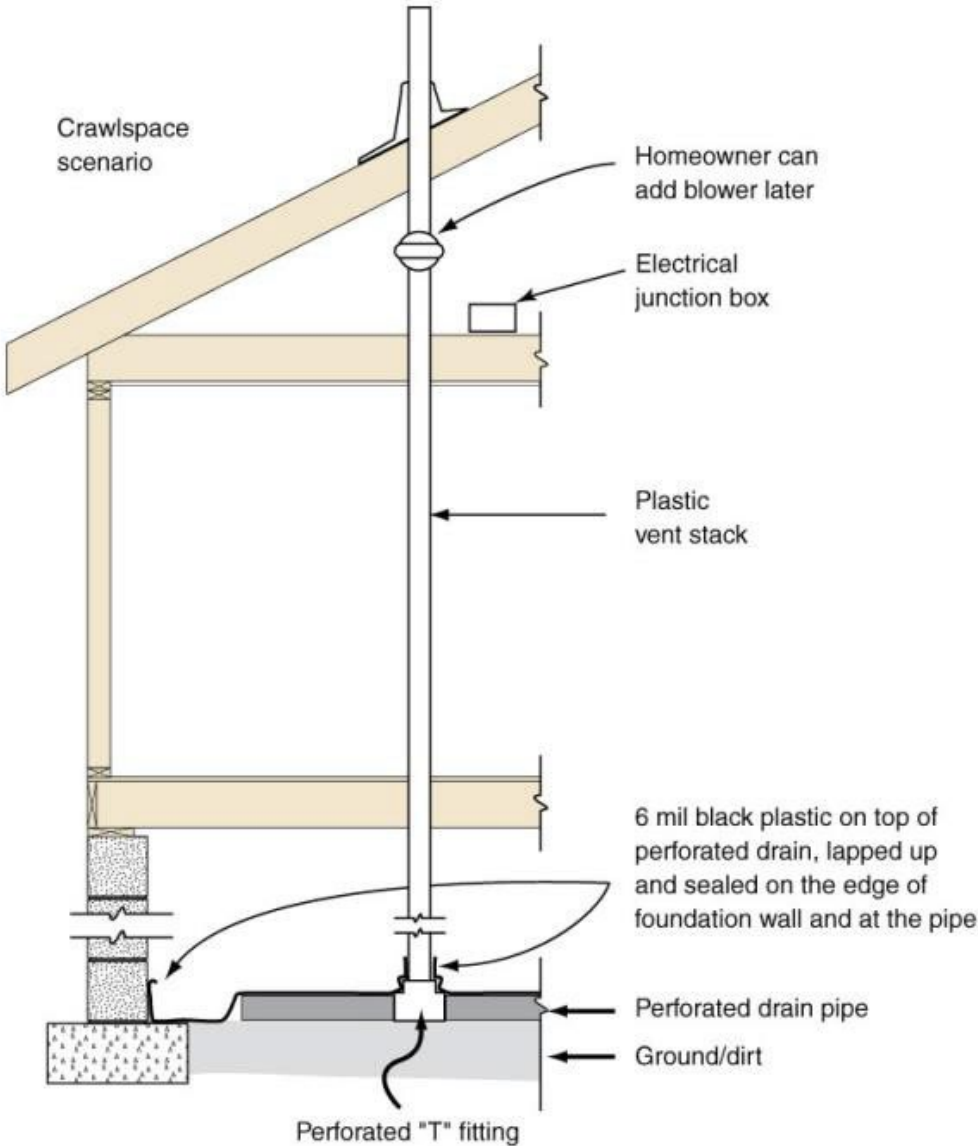

Passive radon resistant construction includes a PVC pipe with a perforated “T” fitting at its base that is installed to terminate through the roof. EarthCraft requires, at a minimum, the radon vent be passive with an electrical junction box installed in the attic for future radon vent fan installation if necessary.

- EPA radon zone maps may be found for every state at: [U.S EPA Radon Zones by County](#)
- Basic radon resistant construction techniques are:
 - A 4" layer of gravel beneath slabs to serve as a gas permeable layer to collect soil gases. In areas where gravel is inappropriate a perforated pipe or collection pipe may be used as an alternative
 - A 3-4" solid PVC Schedule 40 pipe, T'd off at the gravel and installed to connect to piping that will terminate through the building roof. Pipe shall be labeled "Radon System" at every floor.
 - Plastic sheeting that is ≥ 6 mil installed on top of the gravel/base of pipe and beneath the foundation slab.
 - Electrical junction box installed in the attic for future radon vent fan installation if necessary.
- The EPA Radon Resources for Builders and Contractors includes additional guidance: <https://www.epa.gov/radon/radon-resources-builders-and-contractors>

Verification:

- The EarthCraft Technical Advisor will confirm compliance during mid-construction and final inspections.

ES 4.18 Bathroom exhaust fan ductwork size

Criteria: Install bathroom exhaust fan ductwork that is sized for proper airflow. There are two options available for certification credits. Projects may achieve points for only one option.

ES 4.18.A 4-inch ductwork (100%) (1 point)

ES 4.18.B. ≥6-inch ductwork (100%) (2 points)

Additional Information:

- When upsizing ductwork that is larger than the connection point on the bath fan install code approved connection material that allows the ductwork to be connected to the fan without being crimped or impeding the air sealing of the system.

Verification:

- The EarthCraft Technical Advisor will confirm compliance during mid-construction inspections.

ES 4.19 Bathroom exhaust fans rated ≤ 1 sones (2 points)

Criteria: Select and install bath fans for residential units that are rated to operate a noise levels no louder than 1 sone.

Verification:

- The EarthCraft Technical Advisor will confirm compliance during final inspections.
- The builder must submit documentation demonstrating compliance with criteria to the EarthCraft Technical Advisor at the final inspection.

ES 4.20 Automatic bathroom exhaust fan controls with humidistat or timer (2 points)

Criteria: Install either a timer, occupancy sensor or humidity control for all bath fans installed in rooms with tubs, showers or similar sources of moisture.

Additional Information:

- Include instructions for using controls in homeowner manual.
- Provide information on type of system, maintenance, and monitoring requirements in project-specific owner's manual.

Verification:

- The EarthCraft Technical Advisor will confirm compliance during final inspections.

ES 4.21 Energy recovery ventilator for whole-unit ventilation strategy (3 points)

Criteria: Install an energy recovery ventilator (ERV) according to the manufacturer's specifications and meeting ASHRAE 62.2-2010 Whole Building ventilation standards in each residential unit.

Verification:

- The EarthCraft Technical Advisor will confirm compliance during mid-construction and final inspections.

ES 4.22 Dehumidifying ventilation system for whole-unit ventilation strategy (5 points)

Criteria: Install a whole unit dehumidifying ventilator installed to meet ASHRAE 62.2-2010 ventilation airflow requirements in every residential unit. The system must be connected to a drain that terminates at the building exterior.

Verification:

- The EarthCraft Technical Advisor will confirm compliance during mid-construction and final inspections.

ES 4.23 Vent storage room(s) to outside (1 point)

Criteria: Install an exhaust vent in rooms used for storage of cleaning supplies or other hazardous materials. Vent should terminate to the exterior.

Additional Information:

- Vent fan shall be ENERGY STAR qualified.
- The fan(s) shall be installed to provide 20 CFM continuous exhaust.

Clarifications

- No combustion equipment or HVAC equipment may be installed in the storage room.

Verification:

- The EarthCraft Technical Advisor will confirm compliance during mid-construction and final inspections.

ES 5: Water Heater

This section covers water heaters and hot water plumbing within residential units. Hot water systems impact energy and water consumption, both of which are important utilities paid for by residents. Installing efficient hot water systems helps to manage these utility costs.

ES 5.0 No atmospherically vented gas water heaters (requirement)

Criteria: If installing gas storage water heaters within and/or adjacent to residential units none may be atmospherically vented.

Verification:

- The EarthCraft Technical Advisor will confirm compliance during mid-construction and final inspections.

ES 5.1 Heat trap on storage water heater (requirement)

Criteria: If installing storage water heater, either purchase storage water heater with heat trap integrated into the tank or install heat trap on storage water heater. This is a requirement for all projects.

Verification:

- The EarthCraft Technical Advisor will confirm compliance during final inspections.

ES 5.2 Water Heater Efficiencies (requirement)

Criteria: Install storage water heater that meets the energy factor (EF) or Uniform Energy Factor (UEF) requirements in the following table for gas or electric operation. This is a requirement for all projects.

Tank Size	Gas EF	Electric EF	Gas UEF	Electric UEF
20- 55 gal	0.65	0.95	0.61	0.92
55- 100 gal	0.75	1.97	0.76	2.03
< 2 gal	0.82	0.93	0.81	0.91

Clarifications:

- Gas water heaters installed within or adjacent to residential units cannot be atmospherically vented systems.

Verification:

- The EarthCraft Technical Advisor will confirm compliance during final inspections.
- The EarthCraft Technical Advisor will review documentation provided by the builder for compliance with requirements.

ES 5.3 High Efficiency Storage Water Heater (2 points)

Criteria: Install storage water heater that meets the energy factor (EF) or Uniform Energy Factor (UEF) requirements in the following table for gas or electric operation.

Tank Size	Gas EF	Electric EF	Gas UEF	Electric UEF
≤55 gallon	≥0.67	≥2.00	≥0.64	≥2.00
>55 gallon	≥0.77	≥2.20	≥0.78	≥2.20

Verification:

- The EarthCraft Technical Advisor will confirm compliance during final inspections.
- The EarthCraft Technical Advisor will review documentation provided by the builder for compliance with requirements.

ES 5.4 Tankless gas water heater ≥ 0.95 UEF (3 points)

Required for Energy Performance Prescriptive Path

Criteria: Install tankless gas water heater rated at ≥ 0.95 UEF.

Verification:

- The EarthCraft Technical Advisor will confirm compliance during final inspections.
- The EarthCraft Technical Advisor will review documentation provided by the builder for compliance with requirements.

ES 5.5 High Efficiency water heater

Criteria: Install high efficient water heaters in residential units. There are multiple credit options available. Projects may choose one.

ES 5.5.A Solar domestic ($\geq 40\%$ annual load based on unit demand) (4 points)

- **Criteria:** Install solar domestic water heaters to provide hot water for residential units.

ES 5.5.B. ENERGY STAR qualified heat pump water heater ≥ 3.0 UEF (4 points)

- **Criteria:** Install ENERGY STAR certified heat pump water heaters to provide hot water for residential units.

Additional Information:

- ENERGY STAR standards are updated regularly. Confirm selected system meets current ENERGY STAR requirements by verifying system at:
<https://www.energystar.gov/productfinder/product/certified-water-heaters/results>

Verification:

- The EarthCraft Technical Advisor will confirm compliance during final inspections.
- The EarthCraft Technical Advisor will review documentation provided by the builder for compliance with requirements.

ES 5.6 Hot water piping insulation \geq R-4 (100%) (2 points)

Criteria: Using polyethylene, neoprene, fiberglass or other insulation types, insulate all hot water pipes to R-4 or greater.

Additional Information:

- Fit insulation tightly around hot water pipe, face seam down and secure insulation every 2 feet with wire, tape, or clamp.
- Install insulation on all piping elbows to adequately insulate 90-degree bend.

Clarifications:

Hydronic heating systems are not required to insulate pipes in slabs or pipes located in other preapproved materials intended for radiating heat into home.

Verification:

- The EarthCraft Technical Advisor will confirm compliance during mid-construction and final inspections.

ES 6: Lighting/Appliances

This section covers the efficiency of permanently installed lighting fixtures and appliances provided to residences by the developer. Lighting and appliances are important influences on baseload energy consumption, which are reflected within each monthly utility bill for residents. By providing efficient appliances, developments assist their residents with managing their utility costs.

ES 6.0 High-efficacy LED lighting in >90% of all permanent fixtures (requirement)

Criteria: Install high-efficacy LED light bulbs in permanently installed lighting fixtures in residential units and common spaces. This is a requirement for all projects.

Clarifications:

- Lighting included with appliances, such as refrigerators, microwaves, and clothes dryers, does not need to be changed out.
- This requirement applies to all permanently installed interior (including residence and common areas) and exterior (Ex. Patios, breezeway) building light fixtures

Verification:

- The EarthCraft Technical Advisor will confirm compliance during final inspections.

ES 6.1 If installed, ENERGY STAR dishwasher (in residential and common areas) (requirement)

Criteria: Dishwashers provided by the developer in each residential unit and in common areas must be ENERGY STAR qualified. This is a requirement for all projects.

Additional Information:

- ENERGY STAR standards are updated regularly. Confirm selected system meets current ENERGY STAR requirements by verifying system at:
<https://www.energystar.gov/productfinder/product/certified-residential-dishwashers/results>

Clarifications:

- Appliance requirements are only applicable to appliances that are to be installed and maintained by the developer and property maintenance.

Verification:

- The EarthCraft Technical Advisor will confirm compliance during final inspections.

ES 6.2 If installed, ENERGY STAR refrigerator (in residential and common areas) (requirement)

Criteria: Refrigerators provided by the developer in each residential unit and in common areas must be ENERGY STAR qualified. This is a requirement for all projects.

Additional Information:

- ENERGY STAR standards are updated regularly. Confirm selected system meets current ENERGY STAR requirements by verifying system at:
<https://www.energystar.gov/productfinder/product/certified-residential-refrigerators/results>

Clarifications:

- Appliance requirements are only applicable to appliances that are to be installed and maintained by the developer and property maintenance.

Verification:

- The EarthCraft Technical Advisor will confirm compliance during final inspections.

ES 6.3 If installed, ENERGY STAR clothes washer and dryer kits (in residential and/or communal laundry facility) (requirement)

Criteria: Clothes washers and dryers provided by the developer in each residential unit and in common areas must be ENERGY STAR qualified. This is a requirement for all projects.

Additional Information:

- ENERGY STAR standards are updated regularly. Confirm selected system meets current ENERGY STAR requirements by verifying system at:
 - Clothes washers: <https://www.energystar.gov/productfinder/product/certified-clothes-washers/results>
 - Dryers: https://www.energystar.gov/products/clothes_dryers

Clarifications:

- Appliance requirements are only applicable to appliances that are to be installed and maintained by the developer and property maintenance.

Verification:

- The EarthCraft Technical Advisor will confirm compliance during final inspections.

ES 6.4 Residential unit automatic lighting control systems

Criteria: Provide residential units with automatic lighting controls to help reduce use of overhead lighting when rooms are not in use. There are multiple credits available, projects may choose one or all options.

ES 6.4.1. Light fixture(s) in closets operated by motion sensor or timer (1 point)

- Residence closets, including utility rooms, have an automatic lighting control system such as a vacancy sensor or timer with manual-on control.

ES 6.4.2. Light fixture(s) on patio(s) operated by motion sensor, sunlight sensor, or timer (1 point)

- Control exterior lighting at patios and/or patio exterior doors with automatic motion, sunlight sensor, or timer controls that incorporate a photocell to prevent daytime use.

ES 6.4.3. Light fixture(s) at front/primary exterior door operated by sunlight sensor or timer (1 point)

- Control exterior lighting at front/primary doors with sunlight/daylight sensor or timer controls that incorporate a photocell to prevent daytime use.

Verification:

- The EarthCraft Technical Advisor will confirm compliance during final inspections.

ES 6.5 Fixtures and bulbs

Required for Energy Performance Prescriptive Path

Criteria: Install efficient lighting fixtures or bulbs in permanently installed lighting in residential units. There are multiple credits available, projects may choose one option.

ES 6.5.1. ENERGY STAR qualified LED bulbs in all permanently (100%) installed fixtures (2 points)

ES 6.5.2. Ballasted compact fluorescent or LED bulbs in all recessed light fixtures (1 point)

ES 6.5.3. LED bulbs in all permanently (100%) installed fixtures (1 point)

Additional Information:

- ENERGY STAR standards are updated regularly. Confirm selected system meets current ENERGY STAR requirements by verifying system at: https://www.energystar.gov/products/light_fixtures

Verification:

- The EarthCraft Technical Advisor will confirm compliance during final inspections.

ES 7: Common Area Lighting/Appliances

Installing efficient lighting and appliances throughout a multifamily development benefits the entire project beyond the systems that are installed within each residence. EarthCraft Multifamily projects are encouraged to provide efficient systems in these common areas.

ES 7.0 Common Area Lighting Control Systems (multiple credits available):

Criteria: Provide common areas with automatic lighting controls to help reduce use of overhead lighting when rooms are not in use. There are multiple credits available, projects may choose one or all options.

ES 6.7.1. Light fixture(s) in stairwells operated by motion sensor or timer (1 point)

- Lighting in common area stairwells provided with automatic lighting control system such as a motion sensor or timer with manual-on control.

ES 6.7.2. Light fixture(s) in common areas operated by motion sensor or timer (1 point)

- Lighting in common areas have automatic lighting control system such as a motion sensor or timer with manual-on control.

ES 6.7.3. Light fixture(s) in mechanical rooms and maintenance closets operated by motion sensor or timer (1 point)

- Lighting in mechanical closets and maintenance closets have automatic lighting control systems such as a motion sensor or timer with manual-on control.

ES 6.7.4. Outdoor lighting operated by sunlight sensor or timer (1 point)

- Outdoor lighting in parking areas and walkways have automatic controls such as a sunlight sensor or timer with manual-on control.

Verification:

- The EarthCraft Technical Advisor will confirm compliance during final inspections.

ES 7.1 Fixtures and bulbs

Criteria: Install efficient lighting fixtures or bulbs in permanently installed lighting in common areas. There are multiple credits available, projects may choose one option.

ES 6.7.1. ENERGY STAR qualified LED bulbs in all permanently (100%) installed fixtures (2 points)

ES 6.7.2. Ballasted compact fluorescent or LED bulbs in all recessed light fixtures (1 point)

ES 6.7.3. LED bulbs in all permanently (100%) installed fixtures (1 point)

Additional Information:

- ENERGY STAR standards are updated regularly. Confirm selected system meets current ENERGY STAR requirements by verifying system at: https://www.energystar.gov/products/light_fixtures

Verification:

- The EarthCraft Technical Advisor will confirm compliance during final inspections.

ES 7.2 High-efficiency exterior lighting

Criteria: Reduce high energy use in exterior lighting environments through improved design practices.

There are multiple options available for certification credits. Projects may achieve points for one or all options. The lighting design must account for the following elements:

- Exterior lighting for sidewalks and parking area lighting
- Design must include exterior lighting mounted to the building (wall packs), tenant porch lighting, and lighting at the building entrance/site entrance
- To achieve this credit, down lighting controls must be included on all exterior light fixtures (Dark Sky Compliant)
- Lighting shutoff controls must be included at all possible locations (porches, site, and building)

ES 7.2.1. Design to reach IES guidelines: Lighting for Exterior Environments (2 points)

- Outdoor Lighting must meet IES guidelines (IESNA publication, RP-33-1999).

ES 7.2.2. Achieve 50% reduction based on Advanced Energy Design Guide (ASHRAE/IES) (2 points)

- Outdoor lighting must meet the 50% reduction based on the Advanced Energy Design Guide. (ASHRAE/IES publication, Advanced Energy Design Guide for Small to Medium Office Buildings)

ES 7.2.3. High efficacy exterior lighting: 100% fluorescent and/or LED bulbs (2 points)

Additional Information:

- Design guidelines can be located at: www.ies.org and www.ashrae.org.

Verification:

- The EarthCraft Technical Advisor will review documentation provided by the project team for compliance with criteria and will visually confirm compliance with criteria at final inspection.

ES 7.3 High-efficiency Elevators (2 points)

Criteria: Elevators installed meet efficiency criteria of Traction (ThyssenKrupp), MRL (Machine Room- Less), or equivalent elevator systems.

Verification:

- The EarthCraft Technical Advisor will review documentation provided by the project team for compliance with criteria and will visually confirm compliance with criteria at final inspection.

Water Efficiency

Conserving finite freshwater resources has become vitally important in both protecting our environment and helping sustain economic growth in our region. The use of certain strategies like water-efficient fixtures, water-efficient irrigation systems, and reusing the use of potable water on-site through rainwater or gray water systems can significantly reduce a resident's water consumption as well as their utility bills.

The Water Conservation category emphasizes the efficient use of potable water indoors and outdoors. An EarthCraft project aims to reduce water waste and storm water run-off. Strategies include drought-adapted landscaping, improved plumbing distribution systems and efficient plumbing fixtures.

WE 1: Indoor Water Use

Installing water efficient systems in residences provides a benefit for two utility costs: water and energy. Where water efficient hot water systems save energy and water for residences, low-flow fixtures installed for all water equipment help to maintain affordable water bills as well.

WE 1.0 Unit water pressure ≤ 60 psi (requirement)

Criteria: The static service pressure in a unit must be equal to or less than 60 pounds per square inch (psi). This is a requirement for all projects.

Clarifications

- Units supplied by a municipal water supply must either use pressure regulating valve (PRV) upstream of all fixture connections or provide documentation from the public water supplier stating that water pressure will not exceed 60 psi.
- Units supplied by groundwater wells must meet this requirement by installing a pressure tank.
- Piping for unit fire sprinkler systems is excluded from this requirement and should comply with state and local codes and regulations.

Verification:

Pressure regulating valve:

- The EarthCraft Technical Advisor will visually confirm compliance with criteria during final inspections.

Public water supplier:

- The project team must submit documentation demonstrating compliance with criteria to the EarthCraft Technical Advisor prior to final inspections.
- The EarthCraft Technical Advisor will review documentation provided by the project team for compliance with criteria.

WE 1.1 Meet National Energy Policy Act low flow standards for all fixtures (requirement)

Criteria: All fixtures, unless otherwise specified within these guidelines, should meet the minimum requirements of the National Energy Policy Act for low flow fixtures for indoor and outdoor water use.

Additional Information:

- More information may be found at: <https://www.epa.gov/laws-regulations/summary-energy-policy-act>

Verification:

- The EarthCraft Technical Advisor will visually confirm compliance with criteria during final inspections.

WE 1.2 Detect no leaks at any water-using fixture, appliance, or equipment (requirement)

Criteria: There must be no leaks from any water-using fixture, appliance or equipment as determined by pressure-loss testing and visual inspections. This is a requirement for all projects.

Verification:

- The EarthCraft Technical Advisor will visually confirm compliance with criteria during final inspections.

WE 1.3 EPA WaterSense rated low-flow fixtures (units and common facilities)

Criteria: Install EPA WaterSense rated fixtures that meet the following flow ratings in all residential units and common areas. This is a requirement for all projects.

WE 1.3.1. Toilet (≤ 1.28 avg. gal/flush)

- **Criteria:** All installed toilets must have an average maximum gallon per flush of 1.28 or less.

WE 1.3.2. Lavatory faucet and accessories (≤ 1.5 gpm)

- **Criteria:** All installed bathroom sink faucets and accessories must have a maximum flow rate of 1.5 gallons per minute.

WE 1.3.3. Showerheads (≤ 1.5 gpm)

- **Criteria:** All installed showerheads must have a maximum flow rate of 1.5 gallons per minute or less.

WE 1.3.4. Water-based urinal (≤ 0.5 avg. gal/flush)

- **Criteria:** All installed water-based urinals must have an average maximum gallon per flush of 0.5 or less.

Additional Resources

- A list of WaterSense labeled fixtures can be found at: <http://www.epa.gov/watersense>

Verification:

- The EarthCraft Technical Advisor will visually confirm compliance with criteria during final inspections.

WE 1.4 Insulate hot water piping to \geq R-3 for all hot water piping located in unconditioned space (requirement)

Criteria: Insulate all hot water piping located in unconditioned spaces to \geq R-3. This is a requirement for all projects.

Verification:

- The EarthCraft Technical Advisor will visually confirm compliance with criteria during mid-construction inspections.

WE 1.5 If installed, water treatment system NSF certified, \geq 85% efficient (2 points) Required for Platinum certification

Criteria: Any installed drinking water treatment systems must be certified to meet applicable NSF/ANSI standards with a minimum of 85% efficiency rating.

- NSF/ANSI 42 Drinking Water Treatment Units – Aesthetic Effects
- NSF/ANSI 53 Drinking Water Treatment Units – Health Effects
- NSF/ANSI 55 Ultraviolet Microbiological Water Treatment Systems
- NSF/ANSI 58 Reverse Osmosis Drinking Water Treatment Systems
- NSF/ANSI 62 Drinking Water Distillation Systems.

Each system must yield 85 gallons or greater of treated water for each 100 gallons of water processed.

Verification:

- The project team must present documentation demonstrating compliance with criteria to the EarthCraft Technical Advisor prior submitting the project for certification.
- The EarthCraft Technical Advisor will visually confirm compliance with criteria during mid-construction and final inspections.

WE 1.6 If installed, water softeners certified to NSF/ANSI Standard 44 (2 points)

Required for Platinum certification

Criteria: Any installed self-regenerating water softeners must be certified to meet NSF/ANSI 44.

Additional Information:

Residential Caution Exchange Water Softeners, including the voluntary efficiency rating standards in Section 7 – Mandatory testing for elective claims for efficiency rated systems. These standards state that water softeners must:

- Be a demand-initiated regeneration system (i.e., it must use a flow meter or water hardness sensor to initiate regeneration; devices that use time clock- initiated regeneration [fixed time schedule] do not qualify for the efficiency rating).
- Have a rated salt efficiency of not less than 3,350 grains of total hardness exchange per pound of salt, based on sodium chloride (NaCl) equivalency (477 grams of total hardness exchange per kilogram of salt).
- Not generate more than 5 gallons of water per 1,000 grains of hardness removed during the service cycle (18.9 liters per 64.8 grams of total hardness removed).

Verification:

- The project team must present documentation demonstrating compliance with criteria to the EarthCraft Technical Advisor prior submitting the project for certification.
- The EarthCraft Technical Advisor will visually confirm compliance with criteria during mid-construction and final inspections.

WE 1.7 Store ≤0.5 gal of water between water heater and fixture (2 points)

Required for Platinum certification

Criteria: The hot water distribution system must store no more than 0.5 gallons of water in any piping/manifold between the hot water source and any hot water fixture.

Additional Information:

- To account for the additional water that must be removed from the system before hot water can be delivered, no more than 0.6 gallons of water must be collected from the hot water fixture before hot (105°F) water is delivered.
- If a circulation system is used, it must be on-demand circulation. Continuous circulation systems and circulation systems with timers are not approved methods.
- Project teams are encouraged to design systems to store less than 0.35 gallons of water in any piping/manifold between the hot water source and any hot water fixture to ensure no more than 0.6 gallons of water are collected from the hot water fixture before hot water is delivered.

Nominal Pipe Size (inches)	Liquid Ounces per Foot of Length	Maximum Length of Pipe System	
		System without a Circulation Loop or Heat Trace Line (feet)	System with a Circulation Loop or Heat Trace Line (feet)
1/4*	0.33	50	16
5/16*	0.5	50	16
3/8*	0.75	50	16
1/2	1.5	43	16
5/8	2	32	12
3/4	3	21	8
7/8	4	16	6
1	5	13	5
1 1/4	8	8	3
1 1/2	11	6	2
≥2	18	4	1

** The flow rate for 1/4-inch size is limited to 0.5 gpm; for 5/16 inch size is limited to 1 gpm; for 3/8 inch size is limited to 1.5 gpm.*

Table provided by Gary Klein

Verification:

- The project team must present documentation demonstrating compliance with criteria to the EarthCraft Technical Advisor at the pre-drywall inspection.
- The EarthCraft Technical Advisor will review documentation provided by the project team for compliance with criteria and will visually confirm compliance with criteria at pre-drywall inspection and test compliance at final inspection.

WE 1.8 Ultra-low flow WaterSense labeled fixtures (units and common facilities)

Required for Platinum certification

Criteria: Install ultra-low flow WaterSense labeled fixtures in residences and common spaces. Multiple credits are available, projects may choose one or all options. *This is a requirement for projects seeking Platinum certification.*

WE 1.8.1. Toilets (≤ 1.1 avg. gal/flush) (1 point)

- **Criteria:** All installed toilets must be WaterSense labeled with an average maximum gallon per flush of 1.1 or less.

WE 1.8.2. Lavatory faucet/accessories/aerator (≤ 1.0 gpm) (1 point)

- **Criteria:** All installed bathroom sink faucets, accessories, and/or aerators must be WaterSense labeled with a flow rate of 1.0 gallon per minute or less at 60 psi.

WE 1.8.3. Showerhead (≤ 1.5 gpm) (1 point)

- **Criteria:** All installed showerheads must be WaterSense labeled with a flow rate of 1.5 gallons per minute or less.

WE 1.8.4. Kitchen Faucets (≤ 1.5 gpm at 60 psi) (1 point)

- **Criteria:** Kitchen faucets installed are low-flow, ≤ 1.5 gpm.

Clarifications

- If projects are unable to procure low-flow kitchen faucets that are WaterSense certified, projects may use fixtures that are ASME A112.18.1/CSA B125.1 Plumbing Supply Fittings.

Additional Resources

- A list of WaterSense labeled fixtures can be found at: www.epa.gov/watersense

Verification:

- The EarthCraft Technical Advisor will visually confirm compliance with criteria during final inspections.

WE 1.9 Waterless urinals in common areas, all fixtures (2 points)

Criteria: Install waterless urinals in bathroom facilities.

Additional Information:

- WaterSense certified waterless urinals are rated at a flow of ≤ 0.05 gpf
- Additional information, including a product finder, may be found at:
<https://www.epa.gov/watersense/urinals>

Verification:

- The EarthCraft Technical Advisor will visually confirm compliance with criteria during final inspections.

WE 1.10 Greywater system for toilet flushing (4 points)

Criteria: Install greywater system designed to capture, at a minimum, the greywater from one shower in each unit

Clarifications:

- Any installed greywater system must comply with any and all applicable state and local laws.

Verification:

- The EarthCraft Technical Advisor will visually confirm compliance with criteria during mid-construction and final inspections.

WE 1.11 Rainwater harvest system for toilet flushing (4 points)

Criteria: Install rainwater harvest system with minimum capacity to flush, at a minimum, toilets in common areas.

Clarifications

- Any installed rainwater system must comply with any and all applicable state and local laws.

Verification:

- The project team will submit design documentation and code compliance confirmation during the design review process.
- The EarthCraft Technical Advisor will visually confirm compliance with criteria during mid-construction and final inspections.

WE 1.12 Hot water demand ≤ 0.13 gal of water between loop and fixture and ≤ 2 gal of water in loop between water heater and furthest fixture (2 points)

Criteria: Install a demand-controlled hot water priming loop such that the volume from the loop to the hot water outlets is 0.13 gallons or less.

Additional Information:

- Zone the hot water distribution system so that volume in one or more demand- controlled priming loops is kept to less than 2 gallons from the water heater to the furthest fixture on the loop.
- Install buttons or motion sensors, either wired or wireless, in each hot water location to activate pump(s).
- Meet the installation procedures in ES 1.3: Insulate hot water pipe to $\geq R-3$

Clarifications

- For pipe lengths to volume conversion, see Maximum Length of Pipe or Tube table under WE 1.6: Store ≤ 0.5 gal of water between water heater and fixture.

Verification:

- The project team will submit design documentation and code compliance confirmation during the design review process.
- The EarthCraft Technical Advisor will visually confirm compliance with criteria during mid-construction and final inspections.

WE 1.13 Pipe Insulation

Criteria: Insulate water pipes within project. There are two options available for certification credits. Projects may achieve points for one or both options.

WE 1.13.1 All hot water pipes (located in conditioned and unconditioned space) $\geq R-3$ (2 points)

WE 1.13.2 Cold water pipes located in unconditioned space $\geq R-3$ (1 point)

Verification:

- The EarthCraft Technical Advisor will visually confirm compliance with criteria during mid-construction and final inspections.

WE 1.14 Install leak detection sensors at kitchens, bathroom(s), and laundry in all residential units, or leak monitoring system at main water line to each residential unit (4 points)

Criteria: Install leak monitoring or detection systems in residences

Additional Information:

- The leak detection system selected must be able to notify residents and/or maintenance staff of leak.

Verification:

- The EarthCraft Technical Advisor will visually confirm compliance with criteria during mid-construction and/or final inspections.

WE 2: Outdoor Water Use

Installing water efficient water systems for the multifamily development helps to ensure affordable operations and maintenance costs, especially when projects can design landscaping that relies on little to no potable water for maintenance.

WE 2.0 Cover all exposed soil with 2"-3" mulch layer (requirement)

Criteria: Install mulch to cover planting beds with at least 2 inches but no more than 3 inches of mulch during landscaping installation. This is a requirement for all projects.

Clarifications:

- This requirement applies only to projects installing landscaping.

Verification:

- The EarthCraft Technical Advisor will visually confirm compliance with criteria during final inspections.

WE 2.1 Irrigation system (requirement)

Criteria: Projects installing an irrigation system must meet the minimum design and documentation necessary to ensure proper operation and long-term maintenance. This is a requirement for all projects.

WE 2.1.1. Equipped with a rain sensor shutoff switch

- **Criteria:** Irrigation systems must be equipped with technology (either a rain sensor or soil moisture sensor) that inhibits or interrupts operation of the irrigation system during periods of rainfall or sufficient soil moisture.

WE 2.1.2. Provide operating manual to maintenance team

- **Criteria:** The project team must provide a copy of the manufacturer or installer operating manual or create a document specific to the project system. This document must be made available to the team in a digital format, with the ability to print copies as needed. The operating manual shall contain, at a minimum:
 - Operation schedule and process for updating the schedule as necessary throughout a season/year
 - Maintenance requirements
 - Location of controls on the system
 - Contact information for system designer and/or installer

WE 2.1.3. Provide irrigation system layout to maintenance team

- **Criteria:** The project team must provide the irrigation system layout to the maintenance team. This layout shall provide, at a minimum, details on location and depth of piping, location of system joints/elbows/turns, location of sprinkler heads, and identify if a system contains separate zones.

Verification:

- The EarthCraft Technical Advisor will visually confirm compliance with criteria for WE 2.1.1 during final inspections.
- The EarthCraft Technical Advisor will review documentation provided by the project team for compliance with criteria for WE 2.1.2 and WE 2.1.3.

WE 2.2 If installed, ornamental water features must recirculate water (requirement)

Criteria: Install ornamental water features that recirculate water from the feature itself.

Additional Information:

- Provide information on type of system, maintenance, and monitoring requirements in project-specific maintenance manual.

Verification:

- The EarthCraft Technical Advisor will visually confirm compliance with criteria during final inspections.

WE 2.3 Install plants to maintain $\geq 2'$ distance from building(s) at maturity (requirement)

Criteria: Locate all bushes, shrubs, trees, vines, and other vegetation so that, at maturity, the plantings are $\geq 2'$ from the building exterior.

Clarifications

- To meet the 2' spacing requirement at maturity, most plants will need to be greater than 2' from the building at the time they are installed. Planting distances will need to be based on each specific planting.
- Measurement is from the closest edge of the plant foliage to the building exterior wall(s), not the center or stem of the plant.

Verification:

- The EarthCraft Technical Advisor will visually confirm compliance with criteria during final inspections.

WE 2.4 Landscape design

Required for Platinum certification

Criteria: Create a landscape plan that requires reduced water consumption by design. There are two options available for certification credits. Projects may achieve points for only one option.

WE 2.4.A. Use WaterSense water budget tool to design landscape (3 points)

- **Criteria:** Design and install landscape based on the WaterSense budget tool. The water budget of the landscape must be less than 70% of the evapotranspiration rate.

WE 2.4.B. Turf 40% or less of landscaped area (2 points)

- **Criteria:** Install turf grass on 40% or less of the landscaped area.

Additional Resources

- The Water Sense budget tool and approach can be found online at:
<https://www.epa.gov/watersense/water-budget-tool>

Clarifications

- Projects may qualify for this credit with no installed irrigation system; project team must present results from the WaterSense budget tool demonstrating no irrigation is needed.
- The water budget tool calculates the average evapotranspiration rate in a region based on average soil and average height grass. The tool then allows one to input a landscape plan to determine the water budget of the landscape.

Verification:

WE 2.4.A:

- The project team must submit documentation demonstrating compliance with criteria to the EarthCraft Technical Advisor during the mid-construction inspections.
- The EarthCraft Technical Advisor will visually confirm compliance with criteria during final inspections.

WA 2.4.B:

- The EarthCraft Technical Advisor will visually confirm compliance with criteria during final inspections.

WE 2.5 Vegetate slopes exceeding 25% (1 point)

Required for Platinum certification

Criteria: Install erosion-resistant vegetation on all slopes greater than 25% (i.e. 4 feet of horizontal run per 1-foot vertical rise) or provide terracing to minimize soil runoff during and post-construction.

Clarifications:

- Vegetation must be established during the start of construction and maintained throughout the duration of the development activities.
- Necessary silt fencing to protect plantings and allow for root establishment must be provided

Verification:

- The EarthCraft Technical Advisor will visually confirm compliance with criteria during mid-construction and final inspections.

WE 2.6 Advanced irrigation system design and installation

Required for Platinum certification

Criteria: Design and install irrigation systems that minimize or eliminate the use of potable water for landscaping on the project site. There are multiple credits available; projects may select options that add up to a maximum of 4 points.

WE 2.6.1. Design, install and audit irrigation system through a WaterSense Certified Professional (2 points)

- **Criteria:** Irrigation system must be designed, installed and audited by a WaterSense Certified Professional with the WaterSense program. The system must be checked for leaks by the WaterSense irrigation partner during the post-installation audit.

WE 2.6.2. Micro-irrigation system (e.g., drip irrigation) includes pressure regulator, filter, and flush end assemblies (2 points)

- **Criteria:** If installed, micro-irrigation system (a low-pressure irrigation system that sprays, mists, sprinkles, or drips) includes a pressure regulator, filter, and flush-end assemblies.

WE 2.6.3. Distribution uniformity $\geq 65\%$ lower quarter (2 points)

- Irrigation systems must achieve lower quarter distribution uniformity (DU_{LQ}) of 65 percent or greater. Measure the distribution uniformity on the largest spray-irrigated area during the post-installation audit.

WE 2.6.4. Install sprinklers only on turfgrass, pop-up height $\geq 4"$ (1 point)

- **Criteria:** Install sprinkler heads so that the heads have a 4" or greater pop-up height, matched precipitation nozzles and check valves. Use sprinkler irrigation on turfgrass only, on strips 4' wide or greater, and slopes less than or equal to 4:1.

WE 2.6.5. Establish grow-in phase and post landscape seasonal water schedules at irrigation controller (2 points)

- **Criteria:** Establish grow-in phase and post landscape seasonal water schedules at irrigation controller.
 - Post two watering schedules at the irrigation controller. The first schedule must address the initial grow-in phase of the landscape, and the second schedule must address the established landscape. Both schedules must vary according to the season.

Additional Information:

- A list of WaterSense Certified Professionals may be found at:
 - <https://lookforwatersense.epa.gov/pros/>
- Distribution uniformity is the measure of uniformity of applied irrigation water over an area. DU_{LQ} is the ratio of the average of the lowest 25 percent of measurements to the overall average measurement.

Verification:

- The EarthCraft Technical Advisor will collect necessary design documentation during the Design Review process
- The project team must submit documentation demonstrating compliance with criteria to the EarthCraft Technical Advisor prior to the start of final inspections. The EarthCraft Technical Advisor will review documentation provided by the project team for compliance with criteria.
- The EarthCraft Technical Advisor will visually verify system installation during final inspections.

WE 2.7 Drought-tolerant/native landscaping turf and plants (≥75%) (1 point)**Required for Platinum certification**

Criteria: Install 75% or more drought-tolerant/native landscaping turf and plants.

Additional Resources

- Projects may refer to the state-specific landscaping resources included in SP 3.3: Do not install invasive plant species onsite to find lists of native and/or drought tolerant landscaping.
- Additional information may be found at:
 - University of Florida Gardening Solutions: <https://gardeningsolutions.ifas.ufl.edu/plants/ornamentals/native-plants.html>
 - Georgia Native Plant Society: <https://gnps.org/>
 - North Carolina Native Plant Society: <https://ncwildflower.org/recommended-native-species/>
 - South Carolina Wildlife Federation: <http://www.scwf.org/native-plant-list>
 - Virginia Native Plant Society: <https://vnps.org/virginia-native-plant-guides/>
 - Other areas: A list of drought-tolerant/native landscaping turf and plants may be obtained through a local cooperative extension office.

Verification:

- The landscape designer shall provide a list of selected plants and identify which plants meet the criteria above. The designer must indicate these plants on the site plan.
- The EarthCraft Technical Advisor will verbally and visually confirm compliance with criteria with the project team at the final inspection.

WE 2.8 Test and amend soil (1 point)

Criteria: Test soil in areas that will be used for landscaping. Till and amend soil as needed to provide the appropriate balance of nutrients, pH, organic material content and percolation based on designed landscape. Till soil 3-6 inches deep.

Verification:

- The project team must submit documentation demonstrating compliance with criteria to the EarthCraft Technical Advisor prior to the start of final inspections.
- The EarthCraft Technical Advisor will review documentation provided by the project team for compliance with criteria.

WE 2.9 Alternative irrigation system

Criteria: Design and install an irrigation system that will minimize or eliminate the use of potable water for landscaped areas. There are multiple credit options available, projects may elect an irrigation system that achieves a maximum of 5 points.

WE 2.9.1. Greywater irrigation system (3 points)

- **Criteria:** Install a greywater system for landscape irrigation. The system must be approved by the local building and/or health department, include a tank or dosing basin and collect water from only clothes washers or shower drainage.

WE 2.9.2. Rainwater irrigation system (3 points)

- **Criteria:** Design and install a rainwater harvesting and storage system for landscape irrigation. Size the storage system to hold water from a 1" rainfall event from 50% or greater of the total roof area of the building.

WE 2.9.3. Zone irrigation system for specific water needs in each planting area (2 points)

- **Criteria:** Design irrigation system with zones based on water needs in each planting area. Attention should be given to the sprinklers at the tops and bottoms of sloped areas to prevent runoff. Micro irrigation should be installed on separate zones from the rest of the irrigation system if sprinkler heads are used in other parts of the landscape.

WE 2.9.4. Provide weather station or soil moisture sensor on irrigation system (2 points)

- **Criteria:** Equip irrigation systems with technology that inhibits or interrupts operation of the irrigation system during periods of rainfall or sufficient moisture (e.g., rain sensors, soil moisture sensors).

Clarifications

- For multifamily projects, water captured from HVAC condensate drain may be used to meet the intent of WE 2.9.1.

Verification:

- The project team must submit documentation demonstrating compliance with criteria to the EarthCraft Technical Advisor prior to the start of final inspections.
- The EarthCraft Technical Advisor will review documentation provided by the project team for compliance with criteria.

WE 2.10 Timer on exterior water spigots (1 point)

Criteria: Provide timer controls on exterior water spigots that turn off water flow after a pre-set time

Verification:

- The project team must submit documentation demonstrating compliance with criteria to the EarthCraft Technical Advisor prior to the start of final inspections.
- The EarthCraft Technical Advisor will review documentation provided by the project team for compliance with criteria.

Education and Operations

Without proper resident and operations education, even the best high-performance designs may still be inefficient. The Education and Operations category provides strategies for informing residents and operators of the benefits of an EarthCraft Multifamily unit as well as how to best use energy-efficient features to maximize efficiency.

EO 1: Education

This section covers requirements and credit items for education materials that should be provided to property owners, management, and subcontractors for an EarthCraft Multifamily project.

EO 1.0 Provide property manager with project-specific owner's manual (requirement)

Criteria: Provide property management with a project-specific owner's manual. This is a requirement for all projects.

Manual must contain, at a minimum, the following information:

- Building envelope information:
 - Insulation product(s) used, including manufacturer information and R-values
 - Window manufacturer, U-factor and SHGC data
 - Roofing material manufacturer, product line and warranty information
 - Units tested for envelope and/or duct leakage, with copies of energy code certificates
- HVAC equipment information, including copies of AHRI reports and manufacturer maintenance requirements
- HVAC filter size(s) and MERV ratings
- Ventilation system maintenance and schedule requirements
- All residential unit appliance information for:
 - Refrigerators
 - Dishwashers
 - Clothes washers and dryers
 - Faucets
 - Showerheads
 - Toilets
 - Lighting
- All interior finish product information, including information about product materials
 - Cabinet manufacturer, product line, color(s)
 - Countertop manufacturer, product line
 - Flooring manufacture, product line, color/style(s)
 - Paint manufacturer and color information
- All exterior finish product information

- Paint manufacturer and color information
- Exterior lighting schedule(s)
- Landscaping:
 - Plant list
 - Landscape plan/layout
 - Irrigation system operation instructions

Clarifications

- Equipment manuals are acceptable but should be supplemented with clear and specific instructions to the property manager on when and how equipment should be used.
- Detailed information on credit-specific items achieved by the project are located under that line item in these guidelines.

Verification

- The project team must create a digital file of the owner's manual that may be updated or edited as necessary. The file must be in a format that is able to be shared and opened across different common operating systems (Ex. Windows, macOS).

EO 1.1 Label all storm drains or storm inlets to discourage dumping of pollutants (requirement)

Criteria: Label each storm drain within the development to discourage residents from dumping pollutants in storm drains.

Additional Information:

- Storm drain labels shall be permanently installed at each storm drain.



Example of a storm drain label. Information may include the streams/watershed the drain runs to.

Verification:

The EarthCraft Technical Advisor will visually presence of labels at each storm drain located within the project site.

EO 1.2 Local recycling contact (1 point)

Criteria: Provide residents with information on a location for local recycling if recycling is not collected on site.

Additional Information:

- Resources should include a pamphlet with offsite recycling center/location contact information and address and materials collected that is provided to residents during lease-up, as well as information that is permanently provided as a community resource.
- Recycling resources shall provide residents on proper sorting and cleaning of eligible recyclable material(s).

Clarification:

- The project team is not eligible for this credit if recycling is collected by the local municipality or if the project team provides a recycling center on site.
- Documentation provided during new resident lease-up should be saved as a digital file that may be edited as necessary and printed easily.

Verification:

- The Technical Advisor will review the documentation that is provided to new residents during lease-up.
- The Technical Advisor will verify permanently provided information during final inspections.

EO 1.3 Household hazardous materials resources (1 point)

Criteria: Provide residents with resources on hazardous materials used in common household supplies.

Additional Information:

- Hazardous materials resources that include information on proper storage of cleaning materials, poisonous materials, and materials known to cause skin, eye and respiratory irritations.
- Resources should also include alternatives that are not hazardous or toxic.
- Resources should include printed materials that are provided to new residents during lease-up and that may be provided as a resource in communal areas.

Verification:

- The Technical Advisor will review the documentation that is provided to new residents during lease-up.
- The Technical Advisor will verify permanently provided information during final inspections.

EO 2: Operations and Management

This section provides requirements and resources for projects to ensure that subcontractors are informed about the EarthCraft program and their responsibilities for ensuring the project can achieve certification and meet desired performance and efficiency goals.

EO 2.0 Provide all subcontractors with EarthCraft Multifamily worksheets (requirement)

Criteria: Incorporating high performance measures and green construction technologies requires the review of all operations, not just construction practices, for evaluation of sustainability. The builders who integrate green business strategies into their entire company operations may have the greatest success in market transformation.

- Provide and review the relevant EarthCraft Multifamily measures with each subcontractor to ensure their compliance with the program guidelines.
- This is a requirement for all projects

Verification:

- Copies of the EarthCraft worksheet may be shared with all subcontractors and members of the project team digitally.
- The EarthCraft Technical Advisor may confirm this requirement has been met during the Construction Kick-off and Design Review meetings by documenting attendance and keeping copies of email correspondence.

EO 2.1 Market EarthCraft Multifamily program (1 point)

Criteria: Market the project involvement with the EarthCraft program through a variety of accepted activities, which may include:

- Post an EarthCraft Multifamily sign during construction that is visible from the primary site entrance or along a publicly visible fence.
- Include EarthCraft information on developer website

Verification:

- The EarthCraft Technical Advisor will verbally and visually confirm compliance with criteria during mid-construction and/or final inspections
- Project team will provide documentation to EarthCraft Technical Advisor confirming project has complete eligible activities.

EO 2.2 EarthCraft HVAC training (2 points)

Criteria: Coordinate HVAC specific training with the contractor(s) hired to design and install the mechanical systems in each residential unit and common area.

Additional Information:

- Training must cover the following topics:
 - Proper HVAC sizing and design requirements
 - Whole building ventilation
 - HVAC system ductwork design best practices
 - Air sealing requirements for ducted HVAC systems and at mechanical air handler equipment
 - Ducted HVAC system leakage testing
 - Information specific to the multifamily project
- Training may be led by an EarthCraft Program staff member, the EarthCraft Technical Advisor, or a third party approved by the EarthCraft program
 - Training material and schedule must be agreed up on the EarthCraft Program administrator, project's EarthCraft Technical Advisor and a member of the project development team.
- Training must be completed prior to the finalization of the mechanical equipment (aka purchase of system components) to ensure that the systems have been properly sized.

Verification:

- A copy of the training material and a sign-in sheet documenting all participants must be sent to or maintained by the EarthCraft Technical Advisor.
- If the training is led by the EarthCraft Technical Advisor, a copy of the training materials and training sign-in sheet must be submitted to the EarthCraft program administrator prior to submitting the project for certification.

EO 2.3 EarthCraft resources provided to leasing office and/or included on property website (2 points)

Criteria: Provide EarthCraft specific information to leasing office, which may include a page dedicated to the EarthCraft certification on the property website, to enable future residents to learn about the EarthCraft program.

Verification:

- The EarthCraft Technical Advisor will verbally and visually confirm compliance with criteria during final inspections
- Project team will provide documentation to EarthCraft Technical Advisor confirming project has complete eligible activities.

EO 2.4 EarthCraft training provided to property management prior to completion of certification (2 points)

Criteria: Coordinate property management-specific training with the contractor(s) or staff hired for building maintenance.

Additional Information:

- Training must cover the following topics:
 - Proper HVAC maintenance, including filter replacement, maintenance of condensate lines, regular maintenance of heating and cooling components
 - Proper ventilation system maintenance, including filter replacement, ensuring system operation, monitoring indoor air quality.
 - Information on building envelope components, including air sealing and insulation
 - Information on building finishes, including using low-VOC and no-formaldehyde replacements when necessary
 - Other information specific to the project that will be maintained by onsite property management.
- Training may be led by an EarthCraft Program staff member, the EarthCraft Technical Advisor, or a third party approved by the EarthCraft program
 - Training material and schedule must be agreed on by the EarthCraft Program admin, project's EarthCraft Technical Advisor and a member of the project development team.
- Training must be completed prior to the finalization of the project.

Verification:

- A copy of the training material and a sign-in sheet documenting all participants must be sent to or maintained by the EarthCraft Technical Advisor.
- If the training is led by the EarthCraft Technical Advisor, a copy of the training materials and training sign-in sheet must be submitted to the EarthCraft program administrator prior to submitting the project for certification.

EO 2.5 Environmentally friendly cleaning package for ongoing building maintenance (1 point)

Criteria: The property management group must develop and utilize maintenance guidelines that mandate environmentally preferable cleaning products used by the maintenance/management team.

Additional Information:

- At minimum, these products must be specified and used in all common areas and during cleaning at unit turnover.
- A digital copy of the environmentally friendly cleaning products and methods must be created and kept on file so that it may be used by current and future management teams.

Verification:

- The project team must present management guideline documentation demonstrating compliance with criteria to the EarthCraft Technical Advisor prior to submitting the project for certification.

EO 2.6 Environmental management and building maintenance guidelines for staff (1 point)

Criteria: Develop a written management plan for the property site and building that focuses on environmentally preferable maintenance.

Additional Information:

- Environmental management and building maintenance guidelines include creating an internal guide for property maintenance, both internal and contractors, that ensures long-term use of the plan.
- Plan should include, at a minimum:
 - Landscape practices that minimize the use of potable water; prioritize environmentally friendly fertilizers and weed control; and eliminate the use of pest control practices that are harmful to native species or household pets.
 - Building maintenance schedule that prolongs the life of building materials through regular cleaning and checking materials for exposure to bulk moisture, plant growth and/or pest infestation.
 - Preservation of handicap accessible areas
 - Maintenance of outdoor community spaces and areas for residents to dispose of trash and recycling.

Verification:

- The project team must present management guideline documentation demonstrating compliance with criteria to the EarthCraft Technical Advisor when the project is ready to submit for certification.

EO 2.7 Community Recycling Facility (2 point)

Criteria: Provide onsite recycling for residents if the local municipality does not already provide recycling collection.

Additional Information:

- Onsite recycling collection area should allow for pre-sorting of a minimum of mixed paper, cardboard and Plastics 1 and 2.
- Project must provide a means to transport recycling to an offsite recycling center monthly.
- Recycling collection area shall be labeled and provide residents on proper sorting and cleaning of eligible recyclable material(s).

Clarification:

- The project team is not eligible for this credit if recycling is collected by the local municipality or if the project team provides a recycling center on site.

Verification:

- The Technical Advisor will visually verify location of onsite recycling location and educational resources for proper sorting of materials.
- The project team will provide verification on a monthly recycling pick-up contact/contractor who has been contracted for a minimum of one year.

EO 2.8 Builder quality assurance plan (1 point)

Criteria: The general contractor will create and provide a quality assurance (QA) plan that outlines the required measures and responsible parties within the EarthCraft multifamily program.

Additional Information:

- Plan shall include:
 - The name and contact information for the on-site person responsible for coordinating with the EarthCraft Technical Advisor and ensuring all requirements and credits have been verified appropriately.
 - Process for documenting inspection failures with an action plan for remedying them
 - Method for capturing lessons learned for future projects

Verification:

- The project team must present documentation demonstrating compliance with criteria to the EarthCraft Technical Advisor when the project is ready to submit for certification.

EO 3: Third Party Programs

The EarthCraft program can complement and collaborate with a variety of other building performance programs, including the federally supported ENERGY STAR and WaterSense programs, and building operations programs that may be utilized once the property is occupied. These programs help EarthCraft projects achieve higher levels of performance, increase opportunities for financing, and connect them with additional resources for building operations and maintenance.

EO 3.0 Achieve ENERGY STAR Multifamily Certification (2 Points)

Criteria: Achieve the current national or state-level ENERGY STAR Multifamily certification

Additional Information:

- ENERGY STAR Multifamily New Construction program documents may be found at:
 - <https://www.energystar.gov/partner-resources/residential-new/multifamily-national-page>

Verification:

- The project team must submit completed program worksheets and copies of formal certification documents when submitting project for EarthCraft certification.

EO 3.1 Achieve ENERGY STAR Zero Energy Ready Certification (5 Points)

Criteria: Achieve the current national or state ENERGY STAR Zero Energy Ready Certification

Additional Information:

- ENERGY STAR Multifamily New Construction program documents may be found at:
 - <https://www.energy.gov/eere/buildings/doe-zero-energy-ready-home-zero-multifamily-version-2>

Verification:

- The project team must submit completed program worksheets and copies of formal certification documents when submitting project for EarthCraft certification.

EO 3.2 Achieve EPA Indoor AirPLUS certification (2 points)

Criteria: Certify the project under the Indoor AirPLUS program.

Additional Information:

- EPA Indoor AirPLUS program documents may be found at:
 - <https://www.epa.gov/indoorairplus/indoor-airplus-program-documents>

Verification:

- The project team must submit completed program worksheets and copies of formal certification documents when submitting project for EarthCraft certification.

EO 3.3 Achieve WaterSense New Homes Certification (1 point)

Criteria: Certify the project under the WaterSense homes program

Additional Information:

- EPA WaterSense program documents may be found at:
 - <https://www.epa.gov/watersense/watersense-labeled-homes>

Verification:

- The project team must submit completed program worksheets and copies of formal certification documents when submitting project for EarthCraft certification.

EO 3.4 Enroll in BIT Building program for property operations and maintenance for minimum one year (2 points)

Criteria: Participate in the BIT Building program for a minimum of one-year post construction/occupancy.

Additional Information:

- BIT Building program information may be found at:
 - <https://www.southface.org/bit-building/>

Verification:

- The project team must submit confirmation of enrollment in the BIT Building prior to certification.

EO 3.5 EarthCraft Light Commercial Community Center (3 points)

Criteria: Certify the project's Community Center under the EarthCraft Light Commercial program.

Clarification:

- This credit is only applicable for projects with a community center that is a separate building from the residential building(s) that make up the development. The community center must, at a minimum, include:
 - Leasing office
 - At least one community meeting room
 - A business center that includes accessible computers, printer, and internet
 - Bathroom facilities that may be used by residents and guests

Additional Resources:

- For more information, visit: <http://www.earthcraft.org/light-commercial>

Verification:

- The project must register with both the EarthCraft Multifamily and Light Commercial programs and submit all necessary documentation needed to achieve EarthCraft Light Commercial prior to submitting for EarthCraft Multifamily certification.

Innovation

EarthCraft strives to advance market transformation towards green and high- performance building construction in the Southeast. While the program is comprehensive in scope, new products, technologies and strategies are continuing to be developed supporting the mission of EarthCraft and EarthCraft Builders. The Innovation category is intended to provide builders the opportunity to present new ideas for advancing green home building and reward those implementing cutting-edge technologies. Builders are encouraged to present products, technologies and strategies not covered elsewhere within the EarthCraft program.

IN 1.0 On-site fuel cell or co-generation system (4 points)

Criteria: Install on-site fuel cell or cogeneration system to provide energy (in the form of heat and/or electricity) to project.

Verification:

- The project team must present documentation demonstrating compliance with criteria to the EarthCraft Technical Advisor when the project is ready to submit for certification.

IN 1.1 Solar electric system (10% of project demand) (5 points)

Criteria: The project will utilize a solar electric array with the capacity to offset 10% of electrical load demand required by all building(s) within the development. This power may be directly tied to the building(s) common areas and units or may be transferred to the grid.

Clarifications:

- To qualify, the project team must clearly indicate the expected electrical load requirements of the building(s) within the development and then provide a solar PV design showing that 10% of that demand is attainable.
- Efficient lighting strategies (outlined in IES/ASHRAE design guidelines, see ES 7.2) are encouraged as a first step, to reduce the overall electrical load requirement before installing the required 10% PV capacity at final design.

Verification:

- The project team must present documentation demonstrating compliance with criteria to the EarthCraft Technical Advisor.
- The documentation must include:
 - A letter from the solar designer/installer indicating the kWh production of the solar system installed.
 - The electrical engineer must indicate the total expected electric capacity of the entire building(s) in the project.
 - If tied to the grid, the project team must provide details of the agreement with the power

provider.

IN 1.3 Common areas use solar electric system (80% of demand) (4 points)

Criteria: The project will utilize a solar electric array with the capacity to offset 80% of electrical load demand required by all common areas within the building(s). This power may be directly tied to the building or may be transferred to the grid.

Clarifications:

- To qualify, the project team must clearly indicate the expected electrical load requirements of all common areas (including but not limited to clubhouses, offices, hallways, laundry facilities, bathrooms, outdoor common areas, etc.) and then provide a solar PV design showing that 80% of that demand is attainable.
- Efficient lighting strategies and controls (outlined in IES/ASHRAE design guidelines, see ES 7.2) are encouraged as a first step to reduce the overall electrical load requirement before installing the required 80% PV capacity at final design.

Verification:

- The project team must present documentation demonstrating compliance with criteria to the EarthCraft Technical Advisor.
- The documentation must include:
 - A letter from the solar designer/installer indicating the kwh production of the solar system installed.
 - The electrical engineer must indicate the total expected electric capacity of all common areas within the project.
 - If tied to the grid, the project team must provide details of the agreement with the power provider.

IN 1.4 Housing affordability

Criteria: A percentage of total housing units within the project are reserved for tenants qualifying for a low-income housing assistance program. There are two options available for certification credits. Projects may achieve points for only one option.

IN 1.4.A. ≥20% total units

IN 1.4.B. ≥50% total units

Verification:

- The project team will submit details of affordable housing funding mechanism and the numbers of units qualifying as affordable within the entire development.

IN 1.5 Developer submits 12 months of pre-renovation energy data (5 points)

Criteria: During the design phase, developer works with the EarthCraft Technical Advisor to collect a minimum of 12 months utility data from a representative sample of residential units.

Additional Information:

- The data must be used to help inform the project on measures that will increase energy efficiency in the residences.

Verification:

- The EarthCraft Technical Advisor will include data in design review submission for EarthCraft review

IN 1.6 Project-specific innovation points

Criteria: Prior to certification, submit specifications for innovative products or design features to EarthCraft for approval to qualify for additional points.

Additional Information:

- The number of points awarded are based on the proposed solution or installation and how much energy and/or water the solution is expected to save the project or residents, or how the solution will result in a better living environment for the project residents.

Verification:

- The EarthCraft Technical Advisor will submit to EarthCraft for approval and point award.

Renovations with Additions Supplement

Renovation projects with new construction additions must use this check list in addition to the project Worksheet tab for all requirements at the Certified, Gold and/or Platinum levels. Comply with all additions requirements of this Supplement where applicable. Points taken for measures in the project Worksheet tab must also be installed/implemented in additions.

RE 1.0 Limit framing at all windows and doors (requirement)

Criteria: Limit framing at windows to a maximum of one pair of king studs and one pair of jack studs per window opening to support the header and windowsill. Additional jack studs shall be used only as needed for structural support and cripple studs only as needed to maintain on-center spacing of studs.

Clarification:

- The project team must present construction documents demonstrating structural requirements for excess framing, such as additional jack studs or excess cripple studs, through a letter from a licensed engineer.

Verification:

- The EarthCraft Technical Advisor will visually confirm compliance with criteria during mid-construction inspections.

RE 1.1 Advanced Framing

Required for Platinum and Gold level certifications

Criteria: Traditional wall framing typically uses more studs than necessary to structurally support a wall. This increase in structural studs decreases the amount of available space for insulation. Traditional framing materials (wood, steel) are not good insulators; heat can move through them from one side of the wall to the other. In multifamily buildings this results in heat transfer between a unit and the exterior during winter and summer months.

To reduce the amount of lumber in the walls while allowing more room for insulation, high-efficiency advanced framing uses techniques like thicker studs spaced further apart, two wall studs rather than three or four studs in exterior corners, utilizing ladder framing at interior-exterior wall intersections, providing space for attic insulation above exterior walls, and other techniques that can help residents save energy and money.

There are multiple options available for certification credits. Projects may achieve points for one or all options. **All advanced framing credits are required for projects seeking Platinum or Gold level certification.**

RE 1.2.1. Insulated, 2-stud corners where structurally feasible (3 points)

- **Criteria:** Construct framed walls using advanced framing techniques that allow for reduced framing materials and thermal bridging where structurally feasible. Corner framing techniques that achieve $\geq R-6$ are considered acceptable for achieving this credit.
- **Clarifications:** The use intent of this credit may be achieved through a variety of framing options that allow for insulation coverage within the exterior corner. This includes two-stud corners commonly referred to as “California corners” as well as improved three-stud corners

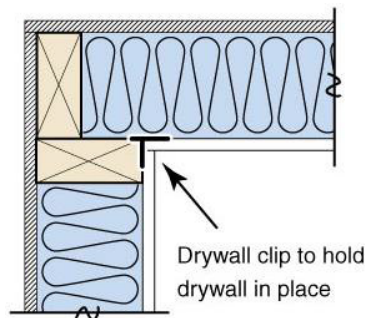

Two-stud corner

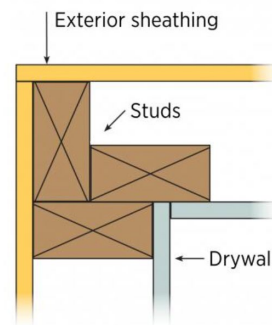

Improved three-stud corner

Two-stud corner details:

- Construct a two-stud corner using a nailing strip or drywall clips, which allows the wall cavity at the corner to be insulated in sequence with the rest of the installation at full wall thickness.
- When drywall clips are used, they should be installed above the level of the interior trim so trim nails will not interfere.

Improved three-stud corner

- Wall assemblies using fiberglass/cellulose batt insulation products must cut the insulation material to fit inside the available cavity space. Batt insulation cannot be compressed.
- **Additional Resources:**
 - Refer to the Building America Solution Center for additional information on insulated corners: <https://basc.pnnl.gov/resource-guides/advanced-framing-insulated-corners#edit-group-scope>

RE 1.2.2 Ladder T-framing at all interior/exterior wall intersections (2 points)

- **Criteria:** Construct exterior/interior wall intersections to reduce framing members and provide continuous insulation where structurally feasible.

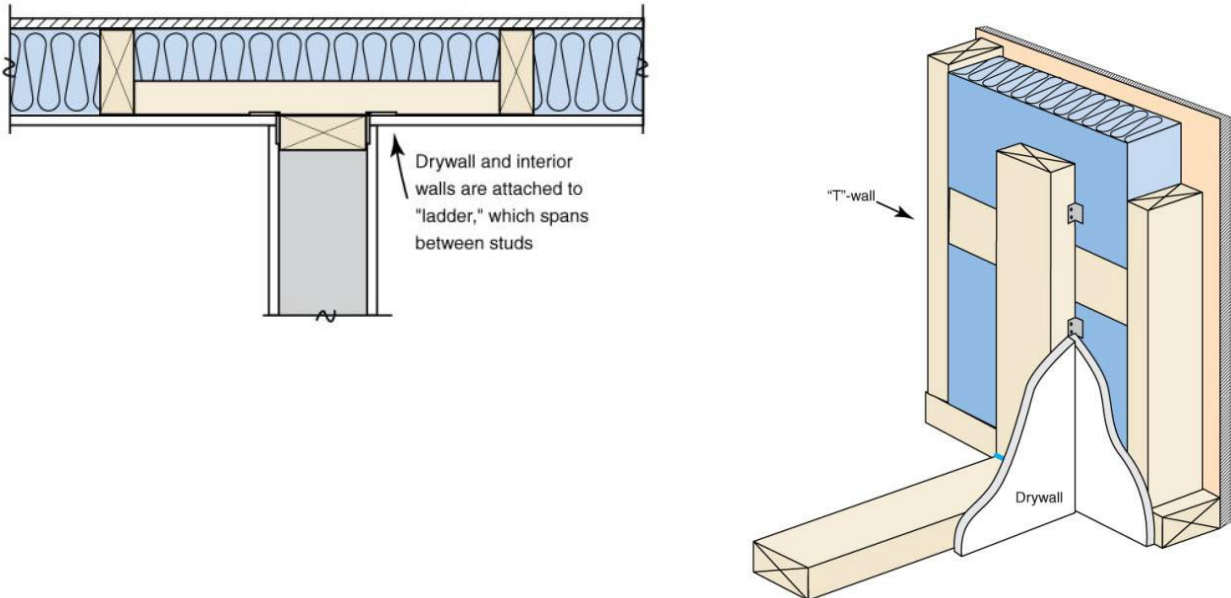

- **Additional Resources:**
 - Refer to the Building America Solution Center for additional information on ladder t-walls, including alternative options for achieving the intent of this credit: <https://basc.pnnl.gov/resource-guides/advanced-framing-insulated-interiorexterior-wall-intersections#edit-group-description>

RE 1.2.3 Size headers for loads (non-structural headers in non-load bearing walls) (1 point)

- **Criteria:** Design and install appropriately sized headers and framing for windows and doors in all walls where structurally feasible. Eliminate load bearing headers in all non-load bearing walls and do not size all headers in load bearing walls to accommodate the greatest load case.
- **Clarifications:**
 - Consult local building codes in areas susceptible to high wind or in seismic regions. If installing a ladder T-wall, begin first ladder 2' above the subfloor to aid in the installation of drywall.
 - Window and door openings should have no more than one pair of king studs, one pair of jack studs, and the minimum number of cripple studs needed to maintain on-center spacing of studs.
- **Additional Resources:**
 - Refer to the Building America Solution Center for more information on minimizing framing at windows and doors: <https://basc.pnnl.gov/resource-guides/advanced-framing-minimal-framing-doors-and-windows#edit-group-scope>

Verification:

- The EarthCraft Technical Advisor will visually confirm compliance with criteria for items RE 1.2.1, RE 1.2.2 and/or RE 1.2.3 during mid-construction inspections.

RE 1.2 Average floor area of unit

There are two options available for certification credits. Projects may achieve points for only one option.

RE 1.2.A. < 800 sq ft (2 points)

- **Criteria:** The average conditioned floor area of all units is less than 800 sq ft.

RE 1.2.B. 800-1,100 sq ft (1 point)

- **Criteria:** The average conditioned floor area of all units is between 800 and 1,100 sq ft.

Clarifications:

- The average floor area must be derived from the areas specified by the conditioned floor areas in the unit schedule.

Verification:

- The project team must present documentation demonstrating compliance with criteria to the EarthCraft Technical Advisor during the EarthCraft Multifamily Design Review meeting and/or Kick-off meeting.
- The EarthCraft Technical Advisor will review documentation provided by the project team for compliance with criteria and will visually confirm compliance with criteria at mid-construction and final inspections.

RE 1.3 Floor joists are 24" on center (≥80%) (1 point)

Criteria: Space at least 80% of all floor joists at 24" on center to minimize material waste.

Verification:

- The project team must present documentation demonstrating compliance with criteria to the EarthCraft Technical Advisor during the EarthCraft Multifamily Design Review meeting and/or Kick-off meeting.
- The EarthCraft Technical Advisor will review documentation provided by the project team for compliance with criteria and will visually confirm compliance with criteria during mid-construction inspections.

RE 1.4 Non-load bearing wall studs are 24" on center (1 point)

Criteria: Space all non-load bearing wall studs at 24" on center.

Clarifications:

- The project team must present construction documents demonstrating structural requirements for excess framing greater than 5%.

Example

Assuming 24" stud spacing, no more than one vertical stud (lacking a structural purpose) for every 30 linear feet of wall would be permitted.

Verification:

- The project team must present documentation demonstrating compliance with criteria to the EarthCraft Technical Advisor during the EarthCraft Multifamily Design Review meeting and/or Kick-off meeting.
- The EarthCraft Technical Advisor will review documentation provided by the project team for compliance with criteria and will visually confirm compliance with criteria during mid-construction inspections.

RE 2.0 Pre-cast insulated foundation walls (≥90%) (2 points)

Criteria: Construct a minimum of 90% of foundation walls using insulated precast concrete foundation walls. Foundation wall insulation must meet the prescriptive requirements for basement of mass walls as applicable in the 2015 IECC with Georgia Amendments or local jurisdiction. Install walls according to manufacturer specifications.

Verification:

- The EarthCraft Technical Advisor will visually confirm during mid-construction inspections.

RE 2.1 Insulated concrete forms or precast autoclaved aerated concrete (≥90%)

There are multiple options available for certification credits. Projects may achieve points for one or all options.

RE 2.1.1. Foundation walls (2 points)

- **Criteria:** Construct a minimum of 90% of foundation walls using either insulated concrete forms (ICF) or precast autoclaved aerated concrete (AAC). Install ICF walls according to manufacturer's specification and meet state termite protection guidelines for ground contact insulation. Install AAC walls according to manufacturer's specifications and meet the prescriptive requirements for basement or mass walls as applicable in the 2015 IECC with Georgia Amendments or code adopted by the local jurisdiction.

RE 2.1.2. Exterior Walls (3 points)

- **Criteria:** Construct a minimum of 90% of exterior walls using either insulated concrete forms (ICF) or precast autoclaved aerated concrete (AAC). Install ICF walls according to manufacturer's specification and meet state termite protection guidelines for ground contact insulation. Install AAC walls according to manufacturer's specifications and meet the prescriptive requirements for mass walls as applicable in 2015 IECC with Georgia Amendments or code adopted by the local jurisdiction.

Additional Resources:

- Refer to the Building America Solution Center for additional information on ICF wall systems and installation best practices.
 - <https://basc.pnnl.gov/resource-guides/insulated-concrete-forms-icfs#edit-group-scope>

Verification:

- The EarthCraft Technical Advisor will visually confirm compliance with criteria during mid-construction inspections.

RE 2.2 Engineered wall framing (≥90%) (1 point)

Criteria: Construct a minimum of 90% of total wall framing using non-solid sawn wood, such as laminated wood (e.g., laminated strand lumber) or finger-jointed studs.

Clarifications:

- Steel studs are not eligible for meeting this credit.
- All non-solid sawn wood products must have no added urea-formaldehyde.

Verification:

- The EarthCraft Technical Advisor will visually confirm compliance with criteria during mid-construction inspections.

RE 2.3 Deliver panelized construction or structurally insulated panels (SIP) to the site pre-framed (≥90%)

There are multiple options available for certification credits. Projects may achieve points for one or all options.

RE 2.3.1. Floors (2 points)

- **Criteria:** Construct a minimum of 90% of the floor area using a panelized floor system (e.g., structurally insulated panels) delivered to the jobsite pre-framed and precut. If installing structurally insulated panels (SIPs), a minimum of R-19 insulation must be used in Climate Zones 2, 3 and 4, demonstrating code compliance for trade-offs where appropriate. In all cases, install panelized floor according to manufacturer specifications.

RE 2.3.2. Exterior walls (2 points)

- **Criteria:** Construct a minimum of 90% of all exterior walls using panelized wall systems (e.g., structurally insulated panels) delivered to the jobsite pre-framed and precut. If installing structurally insulated panels (SIPs), a minimum of R-13 insulation must be used. In all cases, install panelized walls according to manufacturer specifications.

RE 2.3.3. Roof (2 points)

- **Criteria:** Construct a minimum of 90% of the roof area using a panelized roof system (e.g., structurally insulated panels) delivered to the jobsite pre-framed and precut. If installing structurally insulated panels (SIPs), a minimum of R-20 insulation must be used in Climate Zones 2, 3 and 4, demonstrating code compliance for trade-offs where appropriate. In all cases, install panelized roof according to manufacturer specifications.

Clarifications

- Projects constructing sections on site, such as chimneys, do not qualify for this credit. To qualify, only the foundation and porches may be constructed on site.
- Thermal mass and infiltration effects may not be included in R-value.

Verification:

- The EarthCraft Technical Advisor will visually confirm compliance with criteria during mid-construction inspections.

RE 2.4 All residences are modular construction (5 points)

Criteria: Use modular construction (also called prefabrication or off-site construction) for all residences and common buildings within the project.

Additional Resources:

- Refer to the National Renewable Energy Lab report “The Energy in Modular (EMOD) Buildings Method: A Guide to Energy-Efficient Design for Industrialized Construction of Modular Buildings” for additional information on modular design and construction practices.
- Link: <https://www.nrel.gov/docs/fy22osti/82447.pdf>

Verification:

- The EarthCraft Technical Advisor will review construction plans during the pre-construction and design review process. Visual inspections to confirm completion of necessary air sealing, insulation, and/or unit finishes will be completed at mid-construction and final phases of project.

RE 2.5 Structural headers are steel or engineered wood (≥90%) (2 points)

Criteria: A minimum of 90% of the total headers must be manufactured from non-solid sawn wood, such as laminated wood (e.g., laminated veneer lumber [LVL] or laminated strand lumber [LSL]), prefabricated insulated I-joist or steel beams.

Clarifications:

- All non-solid sawn wood products must have no added urea-formaldehyde.

Verification:

- The EarthCraft Technical Advisor will visually confirm compliance with criteria during mid-construction inspections

RE 3.0 Use recycled concrete or alternate material as aggregate in foundation (1 point)

Criteria: At least 30% of coarse aggregate or 10% of fine aggregate in poured concrete structures must be from demolished concrete or alternative material (e.g., crushed porcelain).

Verification:

- The project team must present documentation demonstrating compliance with criteria to the EarthCraft Technical Advisor during the mid-construction inspections.
- The EarthCraft Technical Advisor will review documentation provided by the project team for compliance with criteria prior to submitting project for certification.

RE 3.1 Replace ≥25% of cement in concrete with fly ash or slag

There are multiple options available for certification credits. Projects may achieve points for one or all options.

RE 3.1.1. Slab and/or foundation walls (1 point)

- **Criteria:** Replace 25% of the cement with fly ash or slag in all the concrete used for footings, foundation and basement walls and slabs. This credit may only be achieved if 100% of the foundation (slab and/or foundation walls and footings) contain 25% or more fly ash or slag.

RE 3.1.2. Exterior cladding and trim (1 point)

- **Criteria:** Replace ≥25% of the cement with fly ash or slag in all the concrete used for ≥75% exterior cladding and trim.

Verification:

- The project team must present documentation demonstrating compliance with criteria to the EarthCraft Technical Advisor during the mid-construction inspections.
- The EarthCraft Technical Advisor will review documentation provided by the project team for compliance with criteria prior to submitting the project for certification.

DU 1.0 All roof valleys direct water away from walls, dormers, chimneys, etc. (requirement)

Criteria: Roof must be designed and built so that all roof valleys direct water flow away from walls, dormers, chimneys, or vertical surfaces of any kind.

Verification:

- The EarthCraft Technical Advisor will visually confirm compliance with criteria during all mid-construction inspections

DU 1.1 Install termite mesh system (3 points)

Criteria: Install a termite mesh system that conforms to ASTM A 478 and ASTM A 580/A 580M, Type A1AA marine grade 316 stainless steel mesh of 0.18 mm (0.007") diameter wire with mesh openings of 0.66 x 0.45 mm. (0.026" x 0.018"). Follow manufacturer's installation specifications for proper termite prevention.

Verification:

- The EarthCraft Technical Advisor will visually confirm compliance with criteria during mid-construction inspections.

DU 1.2 All entrance doors have overhang $\geq 3'$ depth (1 point)

Criteria: On all exterior doors, including individual residences, install a covered entry way that extends 3' out from door.

Verification:

- Documentation will be provided demonstrating compliance during the design review phase.
- The EarthCraft Technical Advisor will visually confirm compliance with criteria during mid-construction and final inspections.

DU 2.0 Gravel bed beneath sub-grade slabs, on grade slabs, or raised slabs (requirement)

Criteria: Install a $\geq 4''$ deep gravel bed (consisting of $\geq 0.5''$ clean aggregate) beneath all sub-grade concrete floor slabs or install a $\geq 4''$ of uniform layer of sand with geotextile drainage matting. This is a requirement for all projects.

Clarifications:

- Gravel bed must be installed beneath vapor barrier.

Verification:

- The EarthCraft Technical Advisor will visually confirm compliance with criteria during mid-construction inspections.
- The EarthCraft Technical Advisor will review documentation provided by the project team for compliance with criteria.

DU 2.1 100% coverage of ≥ 6 mil vapor barrier beneath all slabs (requirement)

Criteria: Install a ≥ 6 mil vapor barrier beneath all slabs to prevent soil moisture and gases from entering. Provide 100% coverage. Overlap all vapor barrier joints a minimum of 6". This is a requirement for all projects.

Additional Information:

- No polyethylene or other materials with a perm rating ≤ 0.1 , such as vinyl wallpaper, may be used on below- or above-grade walls of conditioned space, or in any other assembly except under slabs and on crawlspace floors. This is a requirement for all projects.

Verification:

- The EarthCraft Technical Advisor will visually confirm compliance with criteria during mid-construction inspections.
- The EarthCraft Technical Advisor will review documentation provided by the project team for compliance with criteria.

DU 2.2 Foundation drain on top of sub-grade footing (requirement)

Criteria: Install a protected foundation drain tile on top of sub-grade footings. This is a requirement for all projects.

- Use appropriate drain elbows for bends to prevent drainage constriction around corners.
- Surround each pipe with ≥ 6 inches of $\frac{1}{2}$ or $\frac{3}{4}$ inch gravel and wrap gravel layer fully with fabric cloth.
- Discharge all drain lines either away and downhill from the foundation to outside grade/daylight, drywell or to a sump pump.

Additional Information:

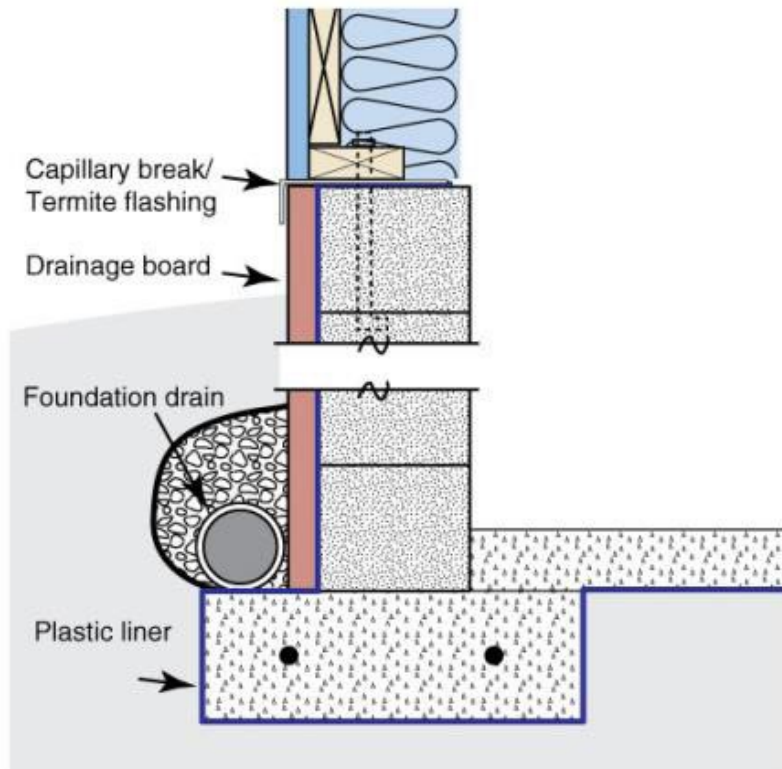

Install a foundation drain that, at its highest, sits on top of or level with the top of below grade footings.

Clarifications:

- Installing the foundation drain at the outside perimeter edge of sub-grading footing and meeting the criteria of DU 2.9 meets this requirement.

Verification:

- The project team must present documentation demonstrating compliance with criteria to the EarthCraft Technical Advisor during mid-construction inspections.
- The EarthCraft Technical Advisor will review documentation provided by the project team for compliance with criteria.

DU 2.4 Final site grade sloped $\geq 1/2$ inch per 1 foot away from the building foundation for ≥ 10 feet or to the edge of the site, whichever is less (requirement)

Criteria: Slope final site grade away from the foundation at a rate of $1/2''$ per 1 foot over a minimum distance of 10 feet.

- Tamp back-fill to prevent settling unless proper drainage can be achieved using non-settling compact soils, as determined by a certified hydrologist, soil scientist, or engineer.

Clarifications:

- Where setbacks limit space to less than 10 feet, install swales or drains designed to carry water away from the foundation.

Verification:

- The EarthCraft Technical Advisor will visually confirm compliance with criteria during mid-construction and final inspections.

DU 2.5 Capillary break between foundation and framing at exterior walls (requirement)

Criteria: Install a capillary break between a concrete foundation wall/slab floor and sill plate. This is a requirement for all projects.

- Install either a complete framed wall width sill gasket, EPDM-type rubber, sheet metal or other suitable membrane to prevent moisture from wicking through the foundation into the framing.
- Capillary break should be installed at all exterior wall locations.

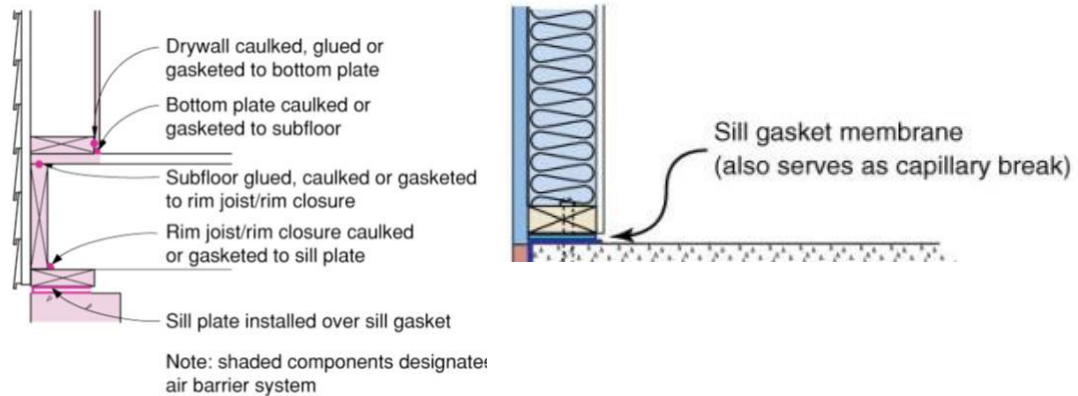

Install a capillary break separating framing materials for the floors/walls and top of the foundation.

Image Credits: Building America Solution Center

Verification:

- The project team must present documentation demonstrating compliance with criteria to the EarthCraft Technical Advisor during mid-construction inspections.
- The EarthCraft Technical Advisor will review documentation provided by the project team for compliance with criteria.

DU 2.6 Drainage board and damp proofing for below-grade walls (requirement)

Criteria: Apply damp proofing and install a drainage plane material that channels water down to the footing drain tile for all below-grade walls. This is a requirement for all projects.

Clarifications:

- Wood-framed below-grade walls are not allowed along the exterior of the building
- Do not install Class I vapor retarders on the interior side of air permeable insulation in exterior below-grade walls, except for tile at showers and tub walls.
- Mirrors may be used if they are mounted with clips or other spacers that allow air to circulate behind them.

Verification:

- The project team must present documentation demonstrating compliance with criteria to the EarthCraft Technical Advisor during mid-construction inspections.
- The EarthCraft Technical Advisor will review documentation provided by the project team for compliance with criteria.

DU 2.7 Do not install wet or water-damaged building materials (requirement)

Criteria: Do not install building materials that have visible signs of water damage or mold. This is a requirement for all projects.

Clarifications:

- If the framing members or the insulation has high moisture content (framing members should be dried to at least 18% moisture content), do not enclose interior walls.
- Follow the manufacturer's drying recommendations for wet-applied insulation and test framing members for moisture prior to enclosing wall cavities.

Verification:

- The EarthCraft Technical Advisor will visually confirm compliance with criteria during mid-construction inspections.
- If high moisture was present:
 - The project team must present documentation demonstrating compliance with criteria to the EarthCraft Technical Advisor during mid-construction inspections.
 - The EarthCraft Technical Advisor will review documentation provided by the project team for compliance with criteria.

DU 2.8 Vapor barriers installed only under slab(s) and/or in crawlspaces (requirement)

Criteria: No polyethylene or other materials with a perm rating ≤ 0.1 , such as vinyl wallpaper, may be used on foundation or above grade walls, or in any other assembly except under slabs and on crawlspace floors. This is a requirement for all projects.

Clarifications:

- Tile is permitted on tub and shower walls and behind counters for backsplash protection.
- No polyethylene or other materials with a perm rating ≤ 0.1 , such as vinyl wallpaper, may be used on below- or above-grade walls of conditioned space, or in any other assembly except under slabs and on crawlspace floors. This is a requirement for all projects.

Verification:

- The EarthCraft Technical Advisor will visually confirm compliance with criteria during mid-construction inspections.

DU 2.9 Foundation drain at outside perimeter edge of footing surrounded with 6" clean gravel and fabric filter (2 points)

Required for Platinum and Gold certification

Criteria: Install a protected foundation drain tile so that the top of the drain tile pipe is below the bottom of the concrete slab or crawlspace floor, or alongside the outside perimeter edge of the footing, whichever is lower. This credit is required for projects seeking Platinum and Gold level certification.

Additional details include:

- Use appropriate drain elbows for bends to prevent drainage constriction around corners or use an EarthCraft-approved product that meets the same intent.
- Surround each pipe with at least 6" of 1/2" to 3/4" gravel. Wrap gravel layer fully with fabric cloth.
- Discharge all drain lines either away and downhill from the foundation to outside grade/daylight or to a sump

Additional Resources:

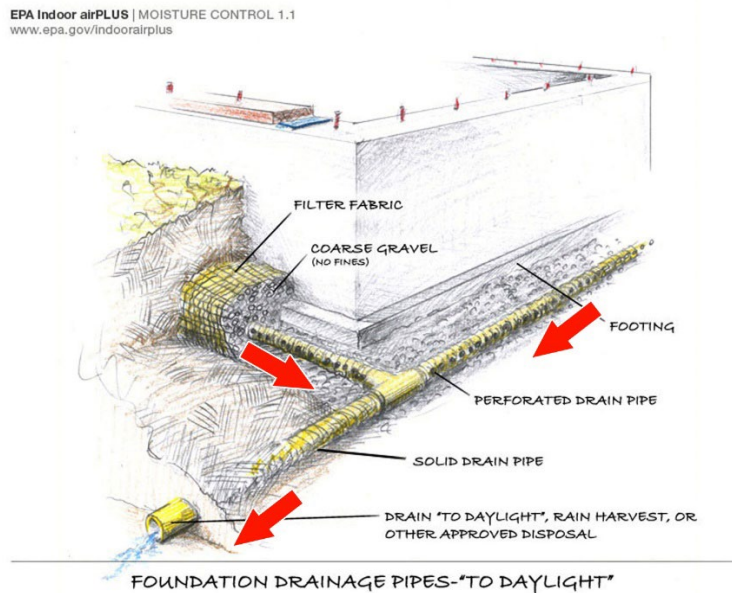
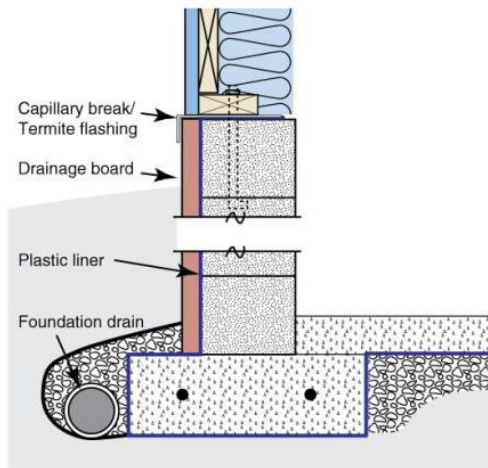

Foundation drain should be installed level with the bottom of the foundation footing.

Image Sources: Building America Solution Center (left) and EPA Indoor AirPLUS (right)

Additional information may be found at:

- Building America Solution Center: <https://basc.pnnl.gov/resource-guides/footing-drain-pipe#edit-group-scope>

Clarifications:

- If radon-resistant features are installed and are incorporated into the foundation drainage system which discharges to daylight, a check valve must be installed at the drain tile outfall.

Verification:

- The project team must present documentation demonstrating compliance with criteria to the EarthCraft Technical Advisor during mid-construction inspections.
- The EarthCraft Technical Advisor will review documentation provided by the project team for compliance with criteria.

DU 2.10 Capillary break

Criteria: Provide additional capillary breaks at foundation level of building. There are multiple options available for certification credits. Projects may achieve points for one or both options.

DU 2.13.1 Between ground and footing or between footing and foundation (2 points)

- **Criteria:** Install plastic to form a capillary break between the ground and the footing or between the footing and foundation. The capillary break must be continuous from the edge of the footing to the slab with an overlapping seam of at least 6 inches and integrated in with the foundation wall drainage system.

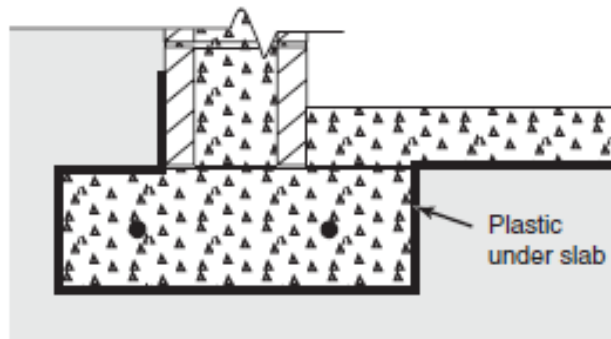

Wrap footing and install a ≥ 6 mil plastic vapor barrier beneath the slab.

DU 2.13.2 Between foundation and framing for all walls (1 point)

- **Criteria:** Install a capillary break between a concrete foundation wall/slab floor and sill plate. Install either a complete framed wall width sill gasket, EPDM-type rubber, sheet metal or other suitable membrane to prevent moisture from wicking through the foundation into the framing. Capillary break should be installed between all foundations and sill plates, not just exterior walls.

Verification:

- The project team must present documentation demonstrating compliance with criteria to the EarthCraft Technical Advisor during mid-construction inspections
- The EarthCraft Technical Advisor will review documentation provided by the project team for compliance with criteria.

BE 1.1 Slab edge insulation: Climate Zone 2/3 ≥R-5, Climate Zone 4 ≥R-10 (3 points)

Criteria: Install exterior slab insulation (Climate Zone 1/2/3 ≥R-4 [heated slabs ≥R-5], Climate Zone 4 ≥R-10 [heated slabs ≥R-15]) so that it extends to the top of the slab. Slab edge insulation must extend to the bottom of the footing or 2', whichever is less.

This is a requirement for projects located in Climate Zone 4 and is optional for projects in Climate Zone 1-3.

Additional Information:

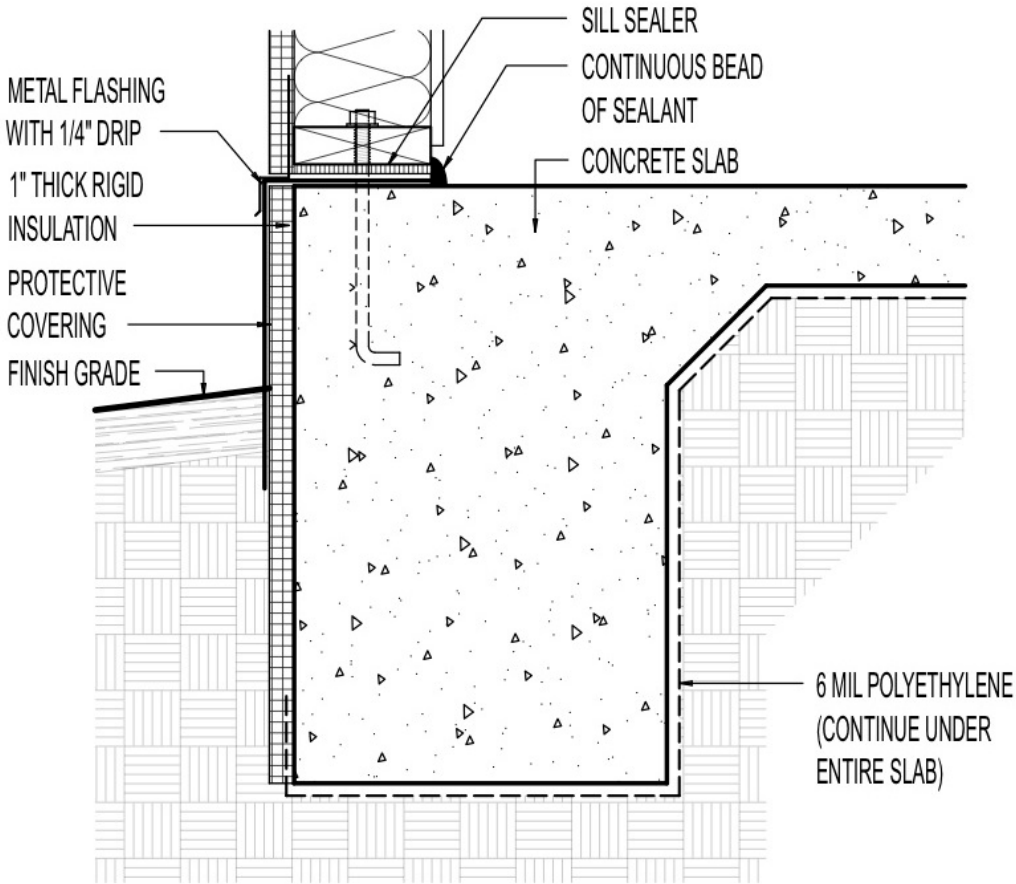

Slab edge insulation installed at the exterior of a monolithic slab with grade beam. Insulation shall be installed in contact with the exterior of the slab and extending to the top of the concrete.

Image Credit: Building America Solution Center, Slab Edge Insulation, <https://basc.pnnl.gov/resource-guides/slab-edge-insulation#edit-group-description>

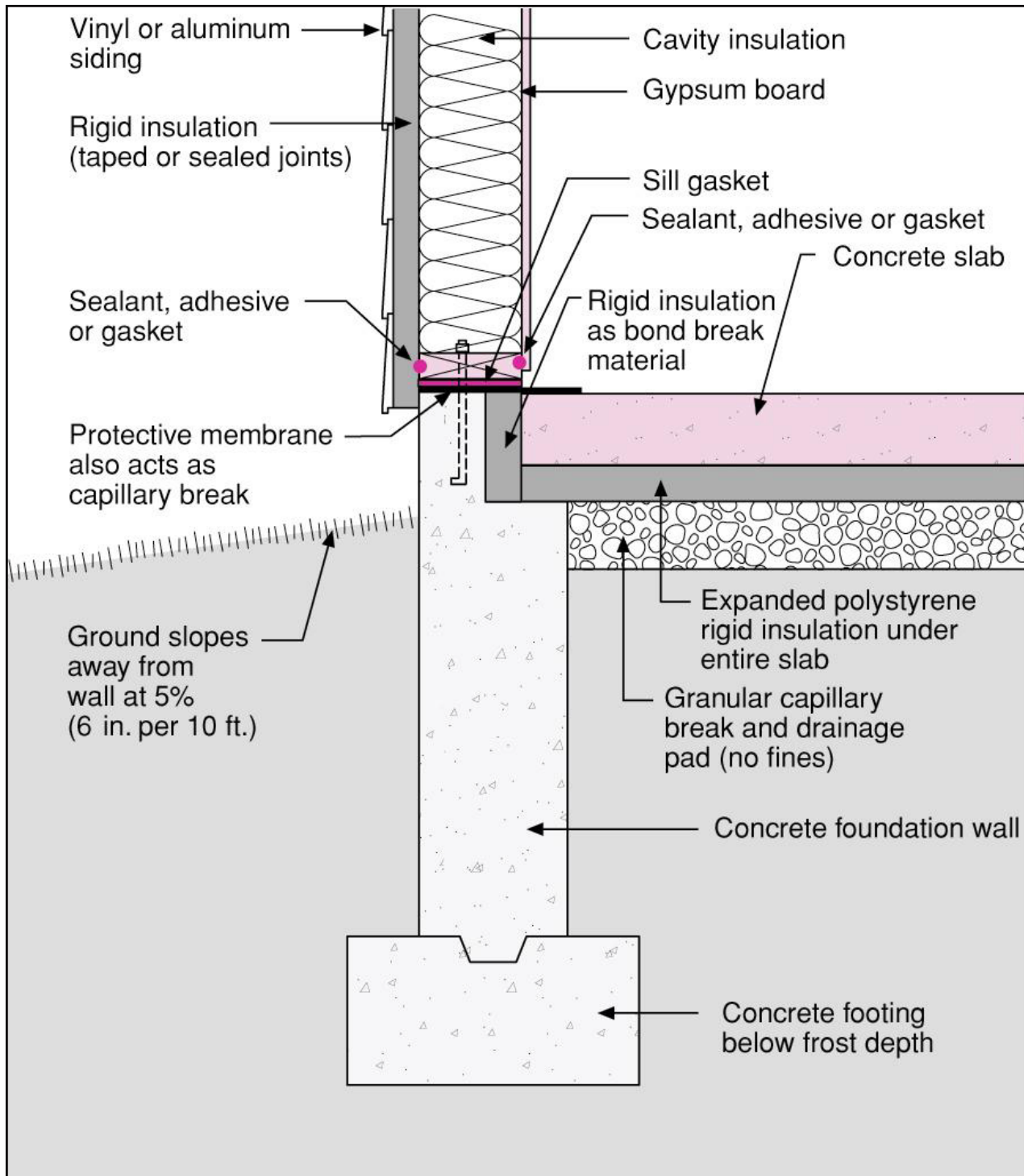

Slab insulation installed beneath slabs that are placed independently from the foundation wall.

Image Credit: Building America Solution Center, Slab Edge Insulation, <https://basc.pnnl.gov/resource-guides/slab-edge-insulation#edit-group-description>

Clarifications:

- Where an insulated wall separates a garage, patio, porch or other unconditioned space from the conditioned space of the building, slab insulation shall also be installed at this interface to provide a thermal break between the conditioned and unconditioned slab, unless the slab is post-tensioned with integrated garage or porch foundations.
- For exterior slab edge insulation, such as for monolithic slabs, install insulation with approved membranes, such as EPDM-type membranes, to protect against termites.
- Non-monolithic slabs may use rigid insulation between the stem wall and the poured (floating) slab, using the protective membrane as a termite flashing and as a capillary break.
- If the top edge of the insulation is installed between the exterior wall and the edge of the interior slab, it may be cut at a 45-degree angle away from the exterior wall.

Exemptions:

- Slab edge insulation is not required in jurisdictions designated by the local code official as having a very heavy termite infestation.
- Slabs greater than 12" below grade as measured from the top of the slab are not required to have insulation.

Verification:

- The EarthCraft Technical Advisor will confirm compliance during mid-construction and final site inspections
- The EarthCraft Technical Advisor will review photo documentation provided by the project team at mid-construction

BE 1.2 Steel-framed buildings require thermal break \geq R-7.5 (requirement)

Criteria: All steel-framed buildings must be insulated with continuous exterior insulation greater than or equal to R-7.5. This is a requirement for all projects.

Clarifications:

- Exterior insulation is required on all walls separating conditioned spaces from unconditioned areas, including ambient environment, garages, and attics.

Verification:

- The EarthCraft Technical Advisor will confirm compliance during mid-construction and final site inspections

ES 2.0 Seal air handlers and duct systems with mastic products (requirement)

Criteria: Seal all seams, joints and connections in forced-air delivery systems using mastic paste or Butyl rubber-backed foil tape (mastic tape). This is a requirement for all projects using ducted HVAC systems. Items to seal include but are not limited to:

- Supply and return ducts
- Supply and return plenums
- Duct-to-plenum connection
- Y-splits, butt joints and boot connections
- Outdoor air intakes
- Air handler condensate and refrigerant line, wire penetrations and unused holes in the air handler cabinet

Additional Information:

Proper air sealing techniques include:

- Using a duct tie and mastic paste or Butyl rubber backed foil tape (mastic tape), connect flex duct liner to sleeve.
- Wrap mastic tape at least two times around duct seam touching at least 1.5" of duct inner liner and metal collar or sleeve.
- Coat duct seams and connections with layer of mastic paste covering seams by 1.5" on both sides and as thick as a nickel.

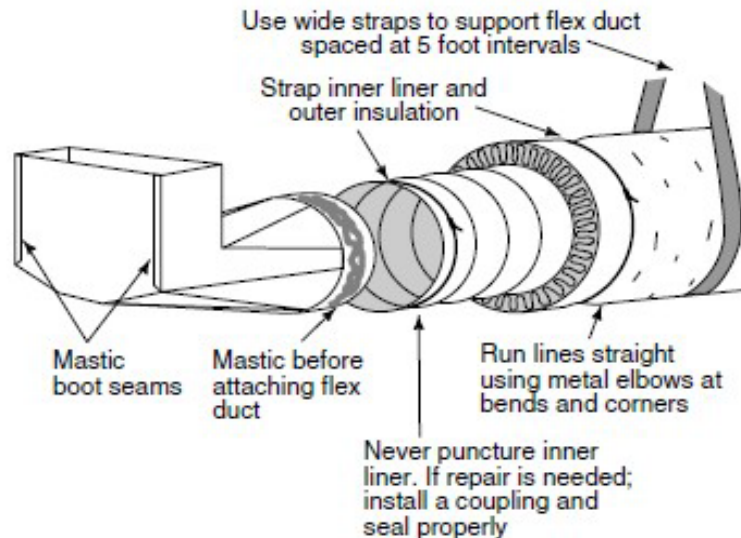

Flexible ductwork (supply and return) should be sealed at the liner to all boots, wyes, and connections using mastic paste or mastic-backed tape. Flexible ductwork should also be installed as straight and short as possible and be supported properly to prevent sagging.

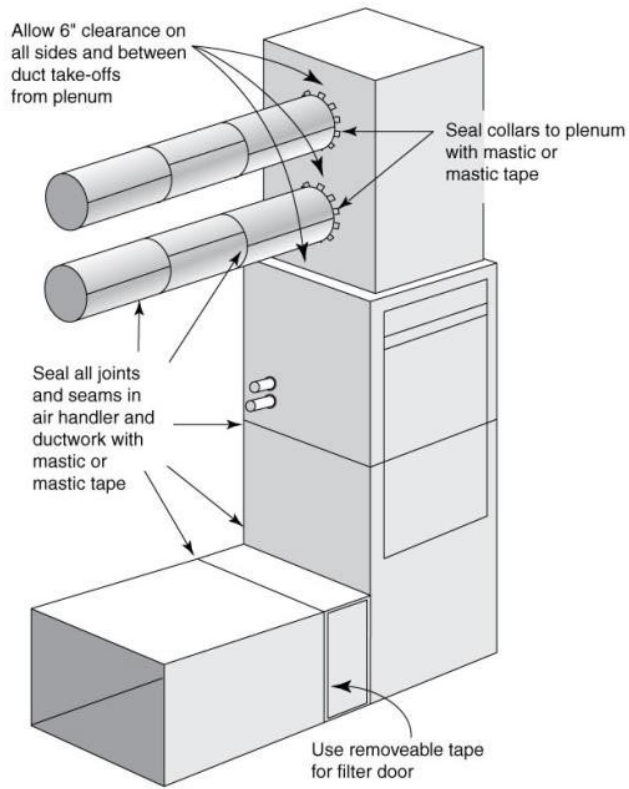

Air seal all joints and penetrations in the air handler and plenums using mastic paste and/or mastic-backed tape.

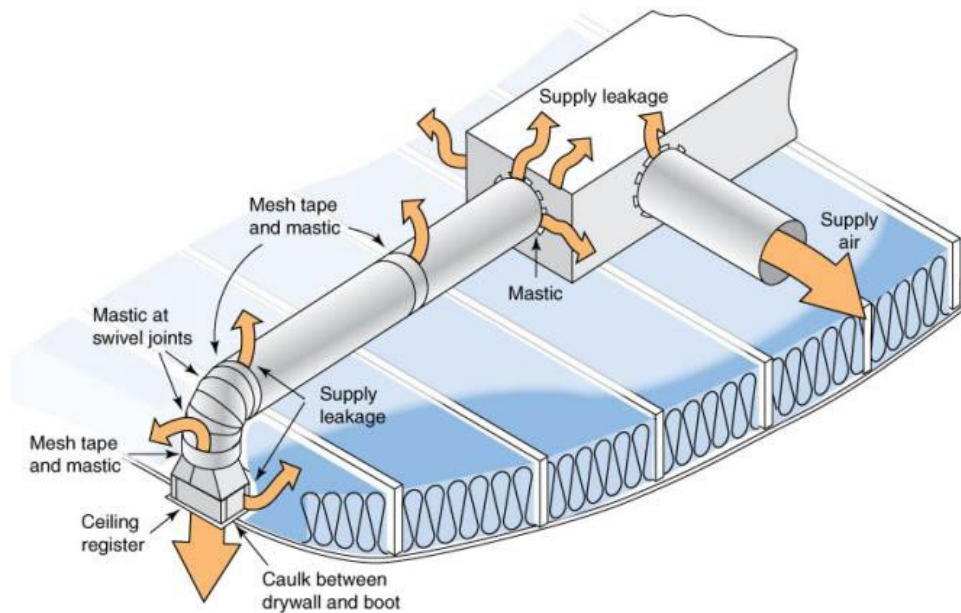

Supply (and return) ductwork should be sealed at the plenum connections, all wyes, and at the boot/register connections.

Clarifications

- Duct tape is not a suitable sealant for ducts. Foil tape may be used only for sealing leaks at the air handler's removable access panels and at filter access panels.
- Caulk, foam, mastic tape or mastic paste may be used to seal duct boots to floor, wall, or ceiling.

Verification:

- The EarthCraft Technical Advisor will confirm compliance during mid-construction and final inspections.

ES 2.1 Code-approved solid connector for all flex-to-flex connections (requirement)

Criteria: Connect all flex-to-flex duct connections together using code-approved rigid connectors or sleeves. This is a requirement for all projects using ducted HVAC systems.

Additional Information:

- Using a duct tie and mastic paste or Butyl rubber backed foil tape (mastic tape), connect flex duct liner to sleeve.
- Wrap mastic tape at least two times around duct seam touching at least 1.5" of duct inner liner and metal collar or sleeve.
- Coat duct seams and connections with layer of mastic paste covering seams by 1.5" on both sides and as thick as a nickel.

Verification:

- The EarthCraft Technical Advisor will confirm compliance during mid-construction and final inspections.

ES 3.0 Test duct leakage based on floor area served (requirement)

Criteria: Quantify HVAC ductwork air leakage on ducted systems. HVAC duct leakage testing procedures shall comply with current RESNET standards and leakage testing equipment manufacturer criteria. This is a requirement for projects of all building heights that use ducted HVAC systems.

ES 3.0.1. Leakage to outside $\leq 3\%$

- **Criteria:** Duct leakage test result for leakage to outside is $\leq 3\%$ of floor area served for all tested systems.

ES 3.0.2. Total leakage $\leq 6\%$ at final

- **Criteria:** Duct leakage test result for total leakage at final is $\leq 6\%$ of floor area served for all tested systems.

Additional Information:

- Duct leakage is calculated using the standard protocol set forth by ASTM for duct pressurization testing at 25 Pascals.
- Duct leakage to outside is defined as the amount of air that leaves HVAC system ductwork outside of the building envelope and is tested separately from total duct leakage.
- Total duct leakage is defined as the amount of total leakage that leaves the HVAC system, including air handler equipment and all ductwork.

Clarifications:

- Both the leakage to the outside and the total leakage duct tests apply to all HVAC systems, even those fully inside the building envelope.
- When energy modeling is used, floor area must equal conditioned floor area used for the confirmed HERS energy model.

Verification:

- The EarthCraft Technical Advisor will confirm compliance during mid-construction and final inspections.

ES 3.1 Test duct leakage based on floor area served

Required for Platinum certification

Criteria: Quantify HVAC duct leakage that is less than the minimum leakage rates required in ES 3.0. HVAC duct leakage testing procedures shall comply with current RESNET standards and leakage testing equipment manufacturer criteria. There are multiple point options available in this credit.

ES 3.1.1. Leakage to outside $\leq 2\%$ (5 points)

- **Criteria:** Duct leakage test result for leakage to outside is $\leq 2\%$ of floor area served for all tested systems.

ES 3.1.2. Total leakage $\leq 4\%$ (5 points)

- **Criteria:** Duct leakage test result for total leakage is $\leq 5\%$ of floor area served for all tested systems.

Clarifications:

- Both the leakage to the outside and the total leakage duct tests apply to all HVAC systems, even those fully inside the building envelope.
- When energy modeling is used, floor area must equal conditioned floor area used for the confirmed HERS energy model.
- Rough-in test results may not be used to achieve either credit.

Verification:

- The EarthCraft Technical Advisor will confirm compliance during final inspections.